

## Short Stroke Electric Actuator

# Series LX

## Direct Acting Guide/Ball Bushing

Series	Motor type	Brake	Guide type	Model	Lead screw <b>lead</b> mm		Page
					Ball screw	Slide screw	
<b>LXF</b>	5 phase stepper	Without brake	Direct acting guide	LXFH5	2 5	6 12	P.870
<b>LXP</b>	2 phase stepper	Without brake	Ball bushing	LXPB2	2 5	6 12	P.878
		With brake			2 5	6 12	P.886
	5 phase stepper	Without brake		LXPB5	2 5	6 12	P.894
		With brake			2 5	6 12	P.902
<b>LXS</b>	2 phase stepper	Without brake	High rigidity direct acting guide	LXSH2	2 5	6 12	P.910
		With brake			2 5	6 12	P.918
	5 phase stepper	Without brake		LXSH5	2 5	6 12	P.926
		With brake			2 5	6 12	P.934

■ CE Marking	P.942
■ Construction	P.954
■ Mounting	P.957
■ Acceleration Time Guide	P.960
■ Table Deflection	P.962

LJ1

LG1

LTF

LC1

LC7

**LXF**

LXP

LXS

LC6□

LZ□

LC3F2

X□

D-□

E-MY

## Part Number Designations

**LX S H 5 B C - 100 S B - M9N 1**

**Actuator configuration**

F	Flat table type
P	Guide rod type
S	Slide table type

**Guide type**

H	Direct acting guide
B	Ball bushing

**Motor type**

2	2 phase stepper motor
5	5 phase stepper motor

**Lead screw type**

B	Ball screw
S	Slide screw

**Lead screw lead**

A	6 mm
B	12 mm
C	2 mm
D	5 mm

**Stroke (mm)**

100	100 mm
-----	--------

**Home position switch**

Nil	None
S	With solid state switch (cable length 0.3 m)

**Brake**

Nil	None
B	With brake

**Number of auto switches/proximity switches**

1	1 pc.
2	2 pcs.
⋮	⋮
6	6 pcs.

**Auto switch/Proximity switch type**

Auto switches	Without auto switch/proximity switch	Proximity switches	With sensor plate, without proximity switch
Nil	Without auto switch/proximity switch	GN	GX-F8A (lead wire length 1 m)
M9N	D-M9N (lead wire length 0.5 m)	G	GX-F8AI (lead wire length 1 m)
M9P	D-M9P (lead wire length 0.5 m)	GD	GX-F8BI (lead wire length 1 m)
F9G	D-F9G (lead wire length 0.5 m)	GB	GX-F8B (lead wire length 1 m)
F9H	D-F9H (lead wire length 0.5 m)	GDB	GX-F8BI (lead wire length 1 m)
F9GL	D-F9GL (lead wire length 3 m)	GU	GXL-8FU (lead wire length 1 m)
F9HL	D-F9HL (lead wire length 3 m)	GUB	GXL-8FUB (lead wire length 1 m)
M9B	D-M9B (lead wire length 0.5 m)		
M9NL	D-M9NL (lead wire length 3 m)		
M9PL	D-M9PL (lead wire length 3 m)		
M9BL	D-M9BL (lead wire length 3 m)		

The tables above show the definition for each symbol only and cannot be used for actual model selection.

# Low Profile Slide Table Type

## 5 Phase Stepper Motor

### Without Motor Brake

# Series LXF

Direct Acting Guide

Ball Screw  
 $\varnothing 8$  mm/2 mm lead

### How to Order

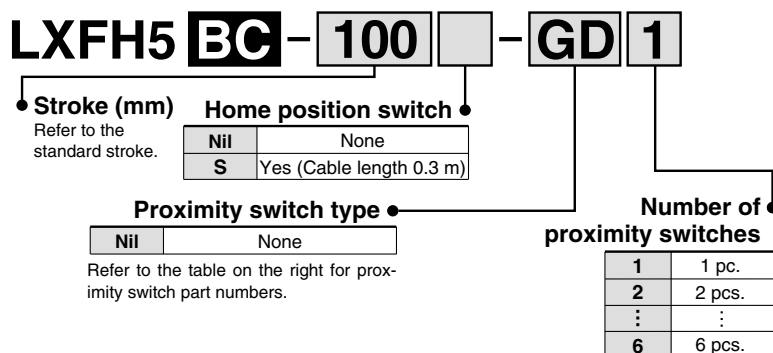

### Proximity switch types

Symbol	Model	Wiring/Output type	Lead wire length (m)	Contact
GN	With sensor rail without proximity switch	—	—	—
G	GX-F8A	3 wire/NPN	1	N.O. (A contact)
GD	GX-F8AI	3 wire/NPN	1	N.O. (A contact)
GB	GX-F8B	3 wire/NPN	1	N.C. (B contact)
GDB	GX-F8BI	3 wire/NPN	1	N.C. (B contact)
GU	GXL-8FU	2 wire/solid state	1	N.O. (A contact)
GUB	GXL-8FUB	2 wire/solid state	1	N.C. (B contact)

\* Refer to page 1082 for detailed specifications of proximity switches.

### Specifications

Standard stroke (mm)		25	50	75	100
Performance	Body mass (kg)	0.8	1.0	1.1	1.2
	Operating temperature range (°C)	5 to 40 (No condensation)			
	Work load (kg)	3 (2) horizontal <sup>Note 1)</sup>			
	Speed (mm/s)	to 30 <sup>Note 2)</sup>			
	Positioning repeatability (mm)	±0.03			
Main parts	Motor	5 phase stepper motor (without brake)			
	Lead screw	Ball screw $\varnothing 8$ mm, 2 mm lead			
	Guide	Direct acting guide			
Home position switch	Model	Photo micro sensor EE-SX672 (Refer to page 1084 for details.)			
Driver	Model	LC6D-507AD-□ (Refer to page 964 for details.)			

Note 1) When mounting a work piece to the actuator's end plate, its mass should be within the value inside ( ).

Note 2) Since vibration may increase with low speed operation, set the driver to be driven in half-step mode, and use 2 mm/s or more as a guide for speed.

### Allowable Moment (N·m)

#### Allowable static moment

Pitching	4
Rolling	3
Yawing	4

m : Transfer load (kg)  
 L<sub>1</sub>, L<sub>2</sub> : Overhang to work piece center of gravity (mm)  
 a : Work piece acceleration (mm/sec<sup>2</sup>)  
 Me : Dynamic moment

#### Allowable dynamic moment

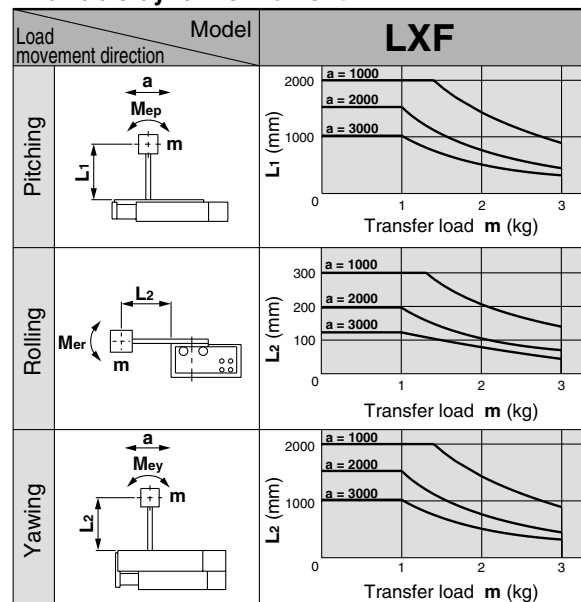

Refer to page 962 for deflection data.



Made to order specifications  
 (For details, refer to page 999)

Symbol	Specifications
X20	AC servomotor specification
X60	Low particulate generation specification

# Low Profile Slide Table Type 5 Phase Stepper Motor/Without Motor Brake **Series LXF**

## Dimensions/LXFH5BC

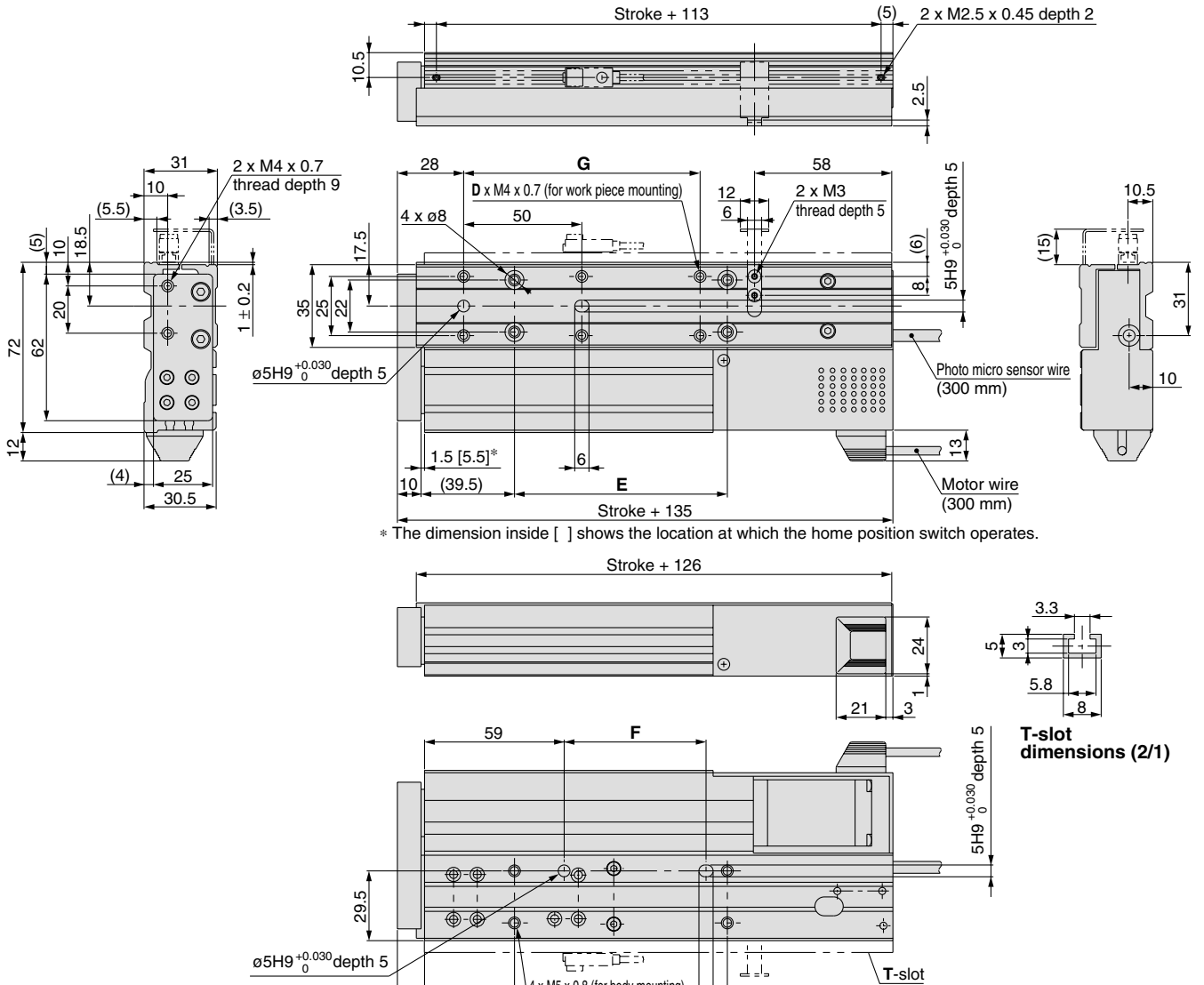

Model	D	E	F	G
LXFH5BC- 25	4	60	30	(50)
LXFH5BC- 50	4	90	60	(50)
LXFH5BC- 75	6	90	60	100
LXFH5BC-100	6	90	60	100

## Positioning Time Guide (for Horizontal Mount)

### For transfer load of 0 kg

		Positioning time (sec)			
		1	10	50	100
Speed (mm/s)	10	0.2	1.1	5.1	10.1
	20	0.1	0.6	2.6	5.1
	30	0.1	0.4	1.7	3.4

### For transfer load of 2 kg

		Positioning time (sec)			
		1	10	50	100
Speed (mm/s)	10	0.2	1.1	5.1	10.1
	20	0.1	0.6	2.6	5.1
	30	0.1	0.4	1.7	3.4

### For transfer load of 1 kg

		Positioning time (sec)			
		1	10	50	100
Speed (mm/s)	10	0.2	1.1	5.1	10.1
	20	0.1	0.6	2.6	5.1
	30	0.1	0.4	1.7	3.4

### For transfer load of 3 kg

		Positioning time (sec)			
		1	10	50	100
Speed (mm/s)	10	0.2	1.1	5.1	10.1
	20	0.1	0.6	2.6	5.1
	30	0.1	0.4	1.7	3.4

Refer to page 961 for acceleration time.

- LJ1
- LG1
- LTF
- LC1
- LC7
- LC8
- LXF**
- LXP
- LXS
- LC6□
- LZ□
- LC3F2
- X□
- D-□
- E-MY

# Low Profile Slide Table Type 5 Phase Stepper Motor Without Motor Brake Series LXF

Direct Acting Guide

Ball Screw  
ø8 mm/5 mm lead

## How to Order

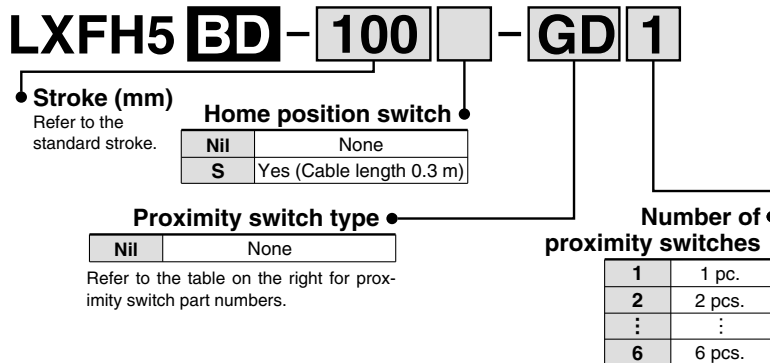

## Proximity switch types

Symbol	Model	Wiring/Output type	Lead wire length (m)	Contact
GN	With sensor rail without proximity switch	—	—	—
G	GX-F8A	3 wire/NPN	1	N.O. (A contact)
GD	GX-F8AI	3 wire/NPN	1	N.O. (A contact)
GB	GX-F8B	3 wire/NPN	1	N.C. (B contact)
GDB	GX-F8BI	3 wire/NPN	1	N.C. (B contact)
GU	GXL-8FU	2 wire/solid state	1	N.O. (A contact)
GUB	GXL-8FUB	2 wire/solid state	1	N.C. (B contact)

\* Refer to page 1082 for detailed specifications of proximity switches.

## Specifications

Standard stroke (mm)		25	50	75	100
Performance	Body mass (kg)	0.8	1.0	1.1	1.2
	Operating temperature range (°C)	5 to 40 (No condensation)			
	Work load (kg)	3 (2) horizontal Note 1)			
	Speed (mm/s)	to 80 Note 2)			
	Positioning repeatability (mm)	±0.03			
Main parts	Motor	5 phase stepper motor (without brake)			
	Lead screw	Ball screw ø8 mm, 5 mm lead			
	Guide	Direct acting guide			
Home position switch	Model	Photo micro sensor EE-SX672 (Refer to page 1084 for details.)			
Driver	Model	LC6D-507AD-□ (Refer to page 964 for details.)			

Note 1) When mounting a work piece to the actuator's end plate, its mass should be within the value inside ( ).

Note 2) Since vibration may increase with low speed operation, set the driver to be driven in half-step mode, and use 5 mm/s or more as a guide for speed.

## Allowable Moment (N·m)

### Allowable static moment

Pitching	4
Rolling	3
Yawing	4

**m** : Transfer load (kg)  
**L1, L2** : Overhang to work piece center of gravity (mm)  
**a** : Work piece acceleration (mm/sec<sup>2</sup>)  
**Me** : Dynamic moment

### Allowable dynamic moment

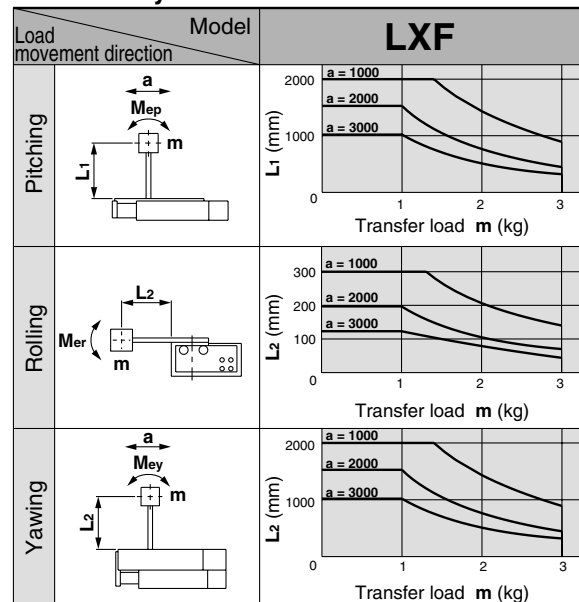

Refer to page 962 for deflection data.



Made to order specifications  
(For details, refer to page 999)

Symbol	Specifications
X20	AC servomotor specification
X60	Low particulate generation specification





# Low Profile Slide Table Type

## 5 Phase Stepper Motor

### Without Motor Brake

# Series LXF

Direct Acting Guide

Ball Screw  
 $\varnothing 8$  mm/6 mm lead

## How to Order

**LXFH5 SA - 100 - M9N 1**

● **Stroke (mm)**  
 Refer to the standard stroke.

**Home position switch**

Nil	None
S	Yes (Cable length 0.3 m)

● **Auto/Proximity switch type**

Nil	None
-----	------

Refer to the table on the right for auto/proximity switch part numbers.

● **Number of auto/proximity switches**

1	1 pc.
2	2 pcs.
⋮	⋮
6	6 pcs.

When using both auto and proximity switches, list the proximity switch part number after the auto switch part number. Example) M9N1G2

## Auto switch types

Symbol	Model	Wiring/Output type	Lead wire length (m)	Contact
Nil	Without auto switch			
M9N	D-M9N	3 wire/NPN	0.5	N.O. (A contact)
M9P	D-M9P	3 wire/PNP	0.5	N.O. (A contact)
M9B	D-M9B	2 wire	0.5	N.O. (A contact)
F9G	D-F9G	3 wire/NPN	0.5	N.C. (B contact)
F9H	D-F9H	3 wire/NPN	0.5	N.C. (B contact)
F9GL	D-F9GL	3 wire/PNP	3	N.C. (B contact)
F9HL	D-F9HL	3 wire/NPN	3	N.C. (B contact)
M9NL	D-M9NL	3 wire/PNP	3	N.O. (A contact)
M9PL	D-M9PL	3 wire/PNP	3	N.O. (A contact)
M9BL	D-M9BL	2 wire	3	N.O. (A contact)

## Specifications

Standard stroke (mm)		25	50	75	100
Performance	Body mass (kg)	0.8	1.0	1.1	1.2
	Operating temperature range (°C)	5 to 40 (No condensation)			
	Work load (kg)	3 (2) horizontal Note 1)			
	Speed (mm/s)	to 100 Note 2)			
	Positioning repeatability (mm)	±0.05			
Main parts	Motor	5 phase stepper motor (without brake)			
	Lead screw	Slide screw $\varnothing 8$ mm, 6 mm lead			
	Guide	Direct acting guide			
Home position switch	Model	Photo micro sensor EE-SX672 (Refer to page 1084 for details.)			
Driver	Model	LC6D-507AD-□ (Refer to page 964 for details.)			

Note 1) When mounting a work piece to the actuator's end plate, its mass should be within the value inside ( ).

Note 2) Since vibration may increase with low speed operation, set the driver to be driven in half-step mode, and use 6 mm/s or more as a guide for speed.

## Proximity switch types

Symbol	Model	Wiring/Output type	Lead wire length (m)	Contact
GN	With sensor rail without proximity switch	—	—	—
G	GX-F8A	3 wire/NPN	1	N.O. (A contact)
GD	GX-F8AI	3 wire/NPN	1	N.O. (A contact)
GB	GX-F8B	3 wire/NPN	1	N.C. (B contact)
GDB	GX-F8BI	3 wire/NPN	1	N.C. (B contact)
GU	GXL-8FU	2 wire/solid state	1	N.O. (A contact)
GUB	GXL-8FUB	2 wire/solid state	1	N.C. (B contact)

\* Refer to page 1082 for detailed specifications of proximity switches.

## Allowable Moment (N·m)

### Allowable static moment

Pitching	4
Rolling	3
Yawing	4

m : Transfer load (kg)  
 L<sub>1</sub>, L<sub>2</sub> : Overhang to work piece center of gravity (mm)  
 a : Work piece acceleration (mm/sec<sup>2</sup>)  
 Me : Dynamic moment

### Allowable dynamic moment

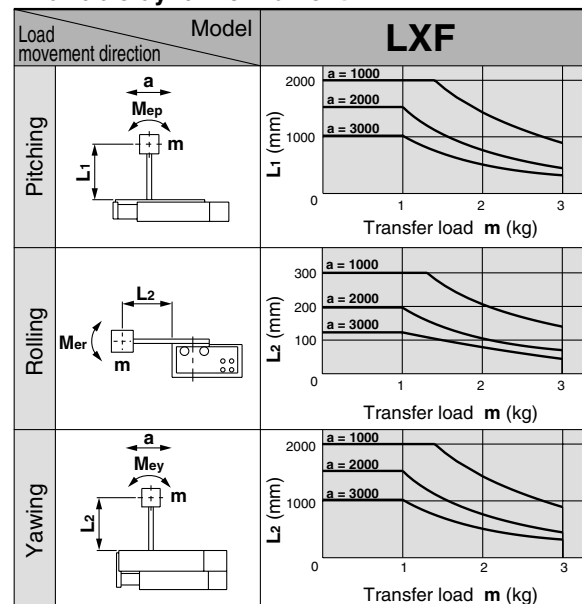

Refer to page 962 for deflection data.

# Low Profile Slide Table Type 5 Phase Stepper Motor/Without Motor Brake **Series LXF**

## Dimensions/LXFH5SA

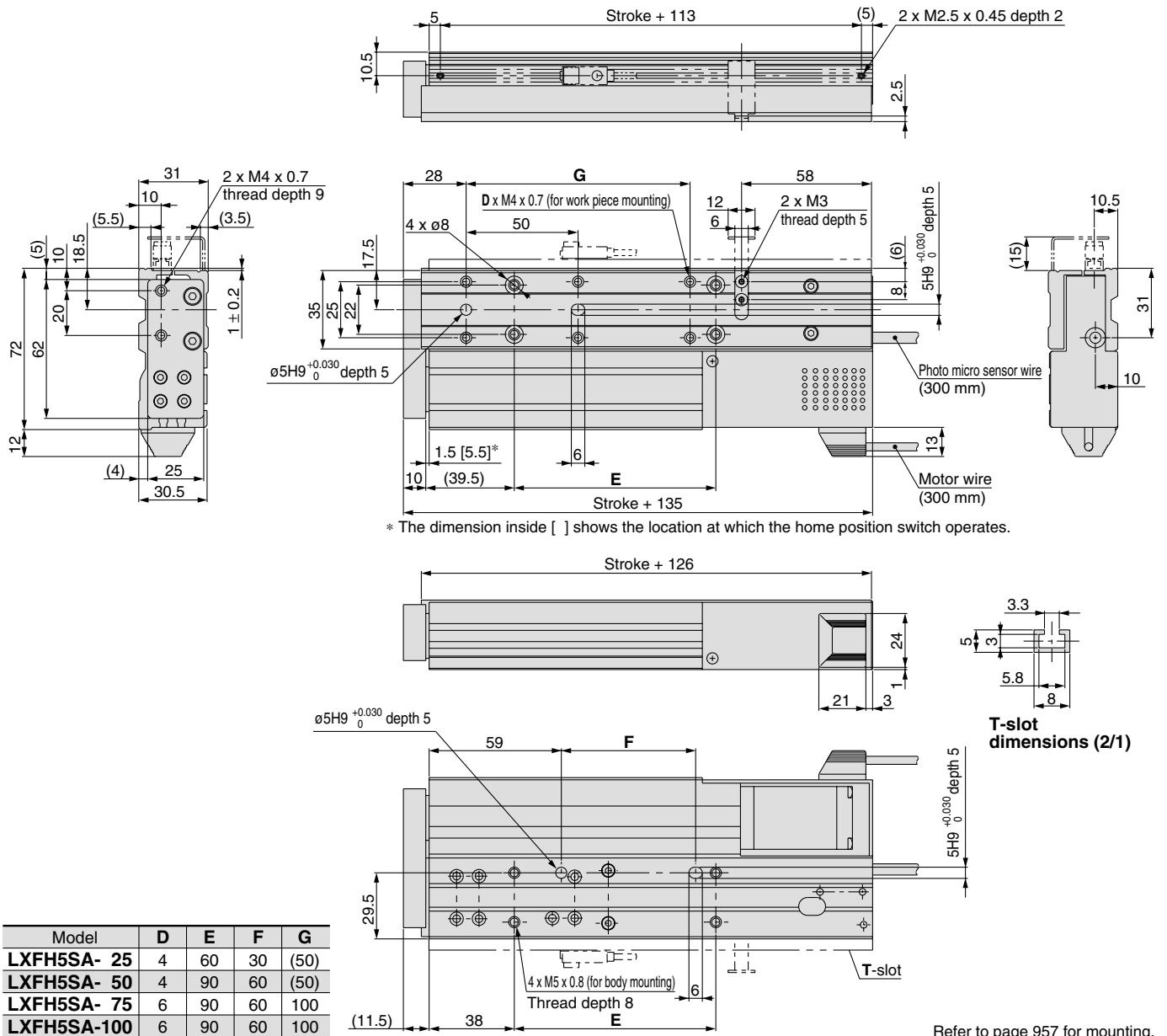

Refer to page 957 for mounting.

## Positioning Time Guide (for Horizontal Mount)

### For transfer load of 0 kg

Positioning distance (mm)		Positioning time (sec)			
		1	10	50	100
Speed (mm/s)	10	0.2	1.1	5.1	10.1
	50	0.1	0.3	1.1	2.1
	100	0.1	0.2	0.6	1.1

### For transfer load of 2 kg

Positioning distance (mm)		Positioning time (sec)			
		1	10	50	100
Speed (mm/s)	10	0.2	1.1	5.1	10.1
	50	0.1	0.3	1.1	2.1
	100	0.1	0.3	0.7	1.2

### For transfer load of 1 kg

Positioning distance (mm)		Positioning time (sec)			
		1	10	50	100
Speed (mm/s)	10	0.2	1.1	5.1	10.1
	50	0.1	0.3	1.1	2.1
	100	0.1	0.2	0.6	1.1

### For transfer load of 3 kg

Positioning distance (mm)		Positioning time (sec)			
		1	10	50	100
Speed (mm/s)	10	0.2	1.1	5.1	10.1
	50	0.1	0.3	1.1	2.1
	100	0.1	0.3	0.7	1.2

Refer to page 960 for acceleration time.

- LJ1
- LG1
- LTF
- LC1
- LC7
- LC8
- LXF**
- LXP
- LXS
- LC6□
- LZ□
- LC3F2
- X□
- D-□
- E-MY

# Low Profile Slide Table Type 5 Phase Stepper Motor Without Motor Brake Series LXF

Direct  
Acting  
Guide

Slide Screw  
∅8 mm/12 mm lead

## How to Order

**LXFH5SB-100-M9N1**

**Stroke (mm)**  
Refer to the standard stroke.

**Home position switch**

Nil	None
S	Yes (Cable length 0.3 m)

**Auto/Proximity switch type**

Nil	None
-----	------

Refer to the table on the right for auto/proximity switch part numbers.

**Number of auto/proximity switches**

1	1 pc.
2	2 pcs.
⋮	⋮
6	6 pcs.

When using both auto and proximity switches, list the proximity switch part number after the auto switch part number. Example) M9N1G2

## Auto switch types

Symbol	Model	Wiring/Output type	Lead wire length (m)	Contact
Nil	Without auto switch			
M9N	D-M9N	3 wire/NPN	0.5	N.O. (A contact)
M9P	D-M9P	3 wire/PNP	0.5	N.O. (A contact)
M9B	D-M9B	2 wire	0.5	N.O. (A contact)
F9G	D-F9G	3 wire/NPN	0.5	N.C. (B contact)
F9H	D-F9H	3 wire/PNP	0.5	N.C. (B contact)
F9GL	D-F9GL	3 wire/NPN	3	N.C. (B contact)
F9HL	D-F9HL	3 wire/PNP	3	N.C. (B contact)
M9NL	D-M9NL	3 wire/NPN	3	N.O. (A contact)
M9PL	D-M9PL	3 wire/PNP	3	N.O. (A contact)
M9BL	D-M9BL	2 wire	3	N.O. (A contact)

## Specifications

Standard stroke (mm)		25	50	75	100
Performance	Body mass (kg)	0.8	1.0	1.1	1.2
	Operating temperature range (°C)	5 to 40 (No condensation)			
	Work load (kg)	2 (2) horizontal Note 1)			
	Speed (mm/s)	to 200 Note 2)			
	Positioning repeatability (mm)	±0.05			
Main parts	Motor	5 phase stepper motor (without brake)			
	Lead screw	Slide screw ∅8 mm, 12 mm lead			
	Guide	Direct acting guide			
Home position switch	Model	Photo micro sensor EE-SX672 (Refer to page 1084 for details.)			
Driver	Model	LC6D-507AD-□ (Refer to page 964 for details.)			

## Proximity switch types

Symbol	Model	Wiring/Output type	Lead wire length (m)	Contact
GN	With sensor rail without proximity switch	—	—	—
G	GX-F8A	3 wire/NPN	1	N.O. (A contact)
GD	GX-F8AI	3 wire/NPN	1	N.O. (A contact)
GB	GX-F8B	3 wire/NPN	1	N.C. (B contact)
GDB	GX-F8BI	3 wire/PNP	1	N.C. (B contact)
GU	GXL-8FU	2 wire/solid state	1	N.O. (A contact)
GUB	GXL-8FUB	2 wire/solid state	1	N.C. (B contact)

\* Refer to page 1082 for detailed specifications of proximity switches.

Note 1) When mounting a work piece to the actuator's end plate, its mass should be within the value inside ( ).

Note 2) Since vibration may increase with low speed operation, set the driver to be driven in half-step mode, and use 12 mm/s or more as a guide for speed.

## Allowable Moment (N·m)

### Allowable static moment

Pitching	4
Rolling	3
Yawing	4

**m** : Transfer load (kg)  
**L1, L2** : Overhang to work piece center of gravity (mm)  
**a** : Work piece acceleration (mm/sec<sup>2</sup>)  
**Me** : Dynamic moment

### Allowable dynamic moment

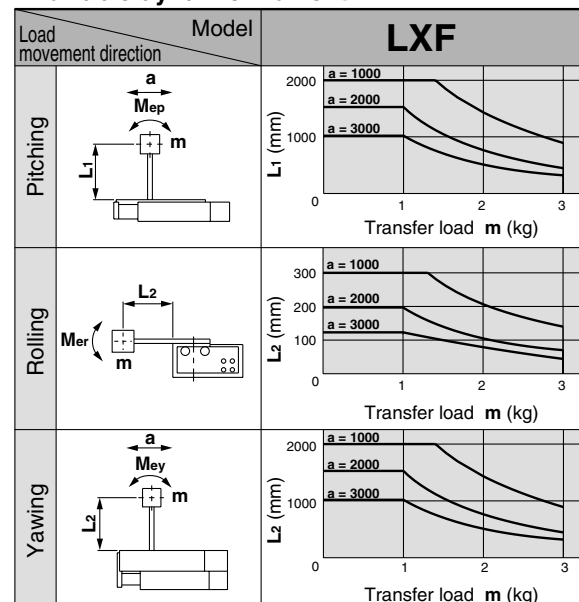

Refer to page 962 for deflection data.



# Low Profile Slide Table Type 5 Phase Stepper Motor/Without Motor Brake **Series LXF**

## Dimensions/LXFH5SB

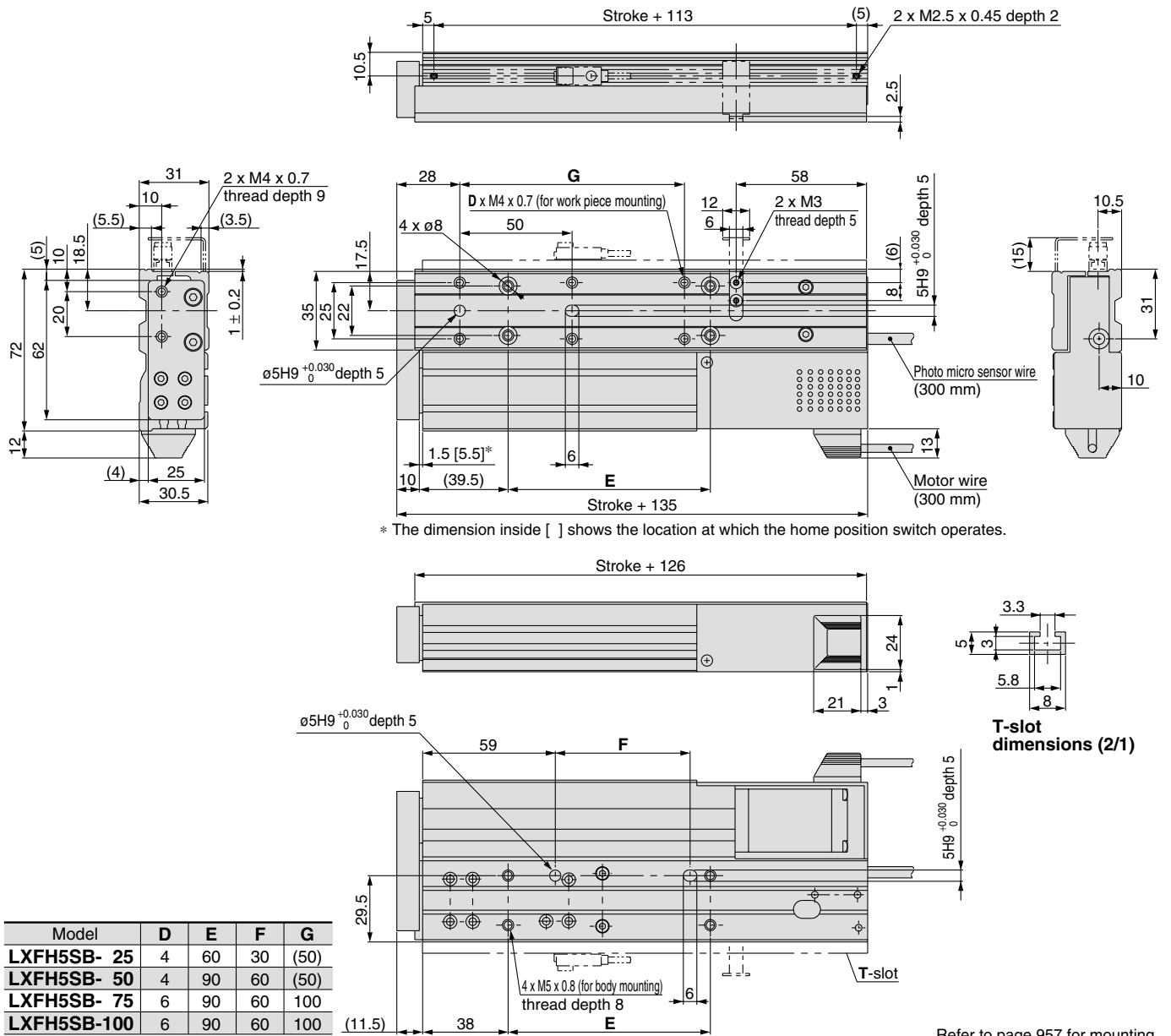

Model	D	E	F	G
LXFH5SB- 25	4	60	30	(50)
LXFH5SB- 50	4	90	60	(50)
LXFH5SB- 75	6	90	60	100
LXFH5SB-100	6	90	60	100

Refer to page 957 for mounting.

## Positioning Time Guide (for Horizontal Mount)

### For transfer load of 0 kg

		Positioning time (sec)			
		1	10	50	100
Speed (mm/s)	50	0.1	0.3	1.1	2.1
	100	0.1	0.2	0.6	1.1
	200	0.1	0.2	0.4	0.6

### For transfer load of 2 kg

		Positioning time (sec)			
		1	10	50	100
Speed (mm/s)	50	0.1	0.3	1.1	2.1
	100	0.1	0.2	0.6	1.1
	200	0.1	0.2	0.5	0.7

### For transfer load of 1 kg

		Positioning time (sec)			
		1	10	50	100
Speed (mm/s)	50	0.1	0.3	1.1	2.1
	100	0.1	0.2	0.6	1.1
	200	0.1	0.2	0.4	0.7

Refer to page 960 for acceleration time.

- LJ1
- LG1
- LTF
- LC1
- LC7
- LC8
- LXF**
- LXP
- LXS
- LC6□
- LZ□
- LC3F2
- X□
- D-□
- E-MY

# Guide Rod Type 2 Phase Stepper Motor Without Motor Brake Series LXP

Ball  
Bushing

Ball Screw  
∅8 mm/2 mm lead

## How to Order

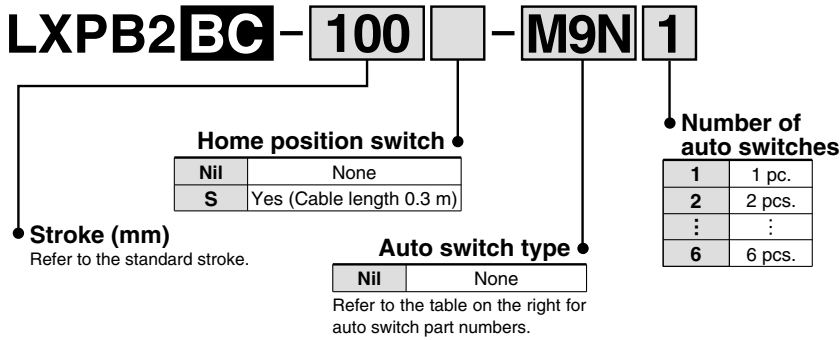

## Auto switch types

Symbol	Model	Wiring/Output type	Lead wire length (m)	Contact
Nil	Without auto switch			
M9N	D-M9N	3 wire/NPN	0.5	N.O. (A contact)
M9P	D-M9P	3 wire/PNP	0.5	N.O. (A contact)
M9B	D-M9B	2 wire	0.5	N.O. (A contact)
F9G	D-F9G	3 wire/NPN	0.5	N.C. (B contact)
F9H	D-F9H	3 wire/PNP	0.5	N.C. (B contact)
F9GL	D-F9GL	3 wire/NPN	3	N.C. (B contact)
F9HL	D-F9HL	3 wire/PNP	3	N.C. (B contact)
M9NL	D-M9NL	3 wire/NPN	3	N.O. (A contact)
M9PL	D-M9PL	3 wire/PNP	3	N.O. (A contact)
M9BL	D-M9BL	2 wire	3	N.O. (A contact)

## Specifications

Standard stroke (mm)		50	75	100	125	150	175	200
Performance	Body mass (kg)	2.0	2.2	2.3	2.6	2.8	2.9	3.1
	Operating temperature range (°C)	5 to 40 (No condensation)						
	Work load (kg)	6 horizontal/5 vertical <sup>Note 1)</sup>						
	Speed (mm/s)	to 30 <sup>Note 2)</sup>						
	Positioning repeatability (mm)	±0.03						
Main parts	Motor	2 phase stepper motor (without brake)						
	Lead screw	Ball screw ∅8 mm, 2 mm lead						
	Guide	Ball bushing						
Home position switch	Model	Photo micro sensor EE-SX673 (Refer to page 1084 for details.)						
Driver	Model	LC6D-220AD-□ (Refer to page 964 for details.)						
Positioning driver	Model	LC6C-220AD (Refer to page 967 for details.)						



**Made to order specifications**  
(For details, refer to page 999)

Symbol	Specifications
X20	AC servomotor specification
X60	Low particle generation specification

Note 1) Based on the operating conditions, establish a separate guide when exceeding the maximum allowable lateral load.

Note 2) Since vibration may increase with low speed operation, set the driver to be driven in half-step mode, and use 2 mm/s or more as a guide for speed.

## Operating Conditions

### Allowable lateral load (F)

Stroke	Load (N)
50	42
75	42
100	40
125	42
150	32
175	24
200	17

### Allowable plate rotation torque (T)

Stroke	Torque (N·m)
50	2.87
75	2.47
100	2.17
125	2.38
150	2.16
175	1.98
200	1.82

### Plate non-rotating accuracy (θ)

Non-rotating accuracy
±0.09°

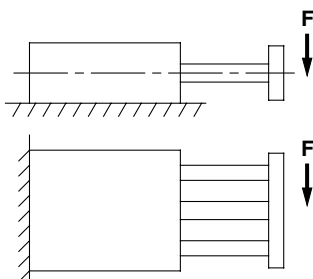
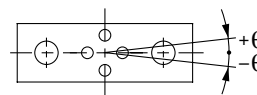

Refer to page 962 for deflection data.

## Dimensions/LXPB2BC

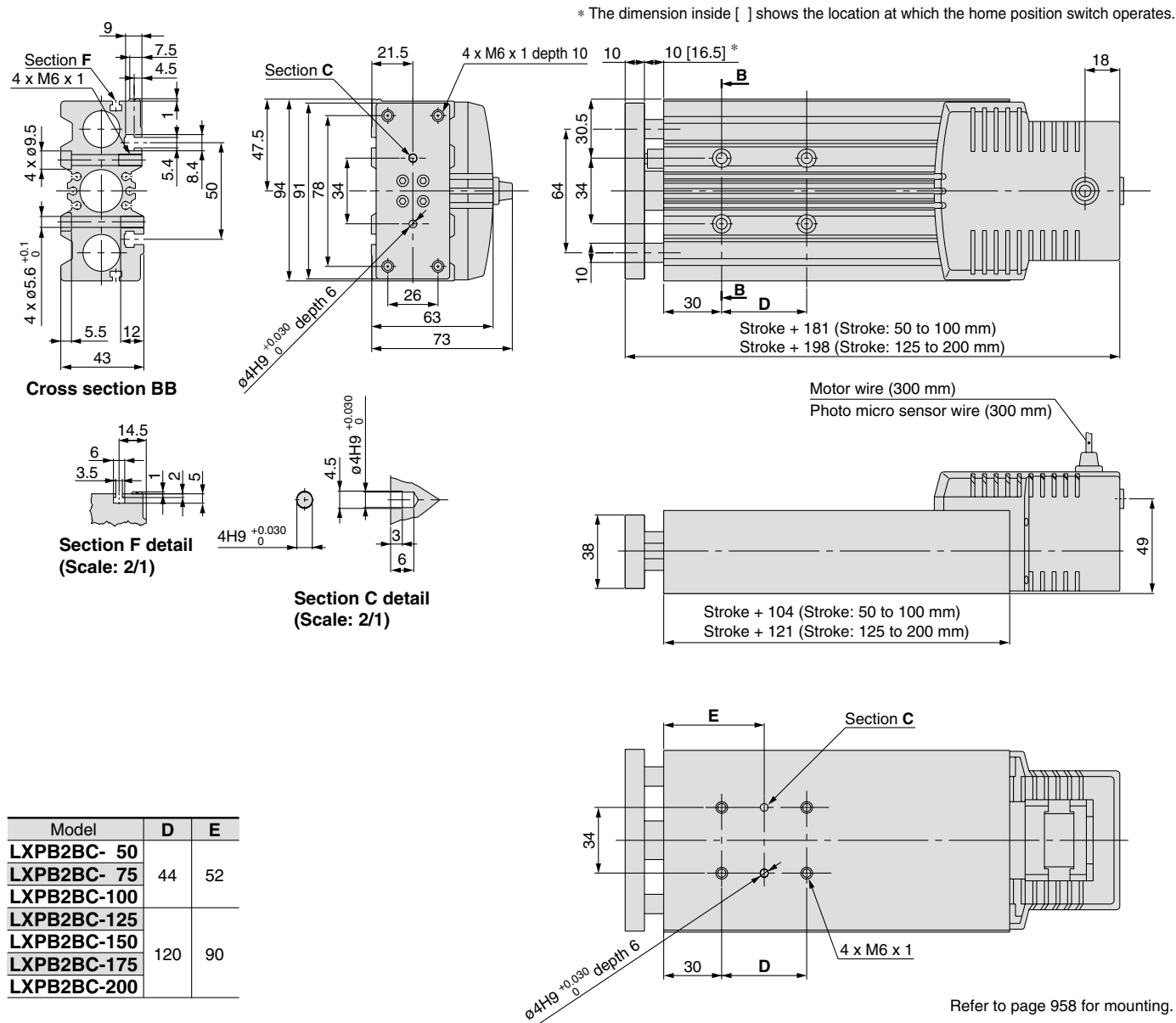

Model	D	E
LXPB2BC- 50	44	52
LXPB2BC- 75		
LXPB2BC-100		
LXPB2BC-125	120	90
LXPB2BC-150		
LXPB2BC-175		
LXPB2BC-200		

## Positioning Time Guide (for Horizontal Mount)

### For transfer load of 0 kg

		Positioning time (sec)				
		1	10	50	100	200
Speed (mm/s)	10	0.2	1.1	5.1	10.1	20.1
	20	0.1	0.6	2.6	5.1	10.1
	30	0.1	0.4	1.7	3.4	6.7

### For transfer load of 6 kg

		Positioning time (sec)				
		1	10	50	100	200
Speed (mm/s)	10	0.2	1.1	5.1	10.1	20.1
	20	0.1	0.6	2.6	5.1	10.1
	30	0.1	0.4	1.7	3.4	6.7

### For transfer load of 3 kg

		Positioning time (sec)				
		1	10	50	100	200
Speed (mm/s)	10	0.2	1.1	5.1	10.1	20.1
	20	0.7	0.6	2.6	5.1	10.1
	30	0.1	0.4	1.7	3.4	6.7

Refer to page 961 for acceleration time.

- LJ1
- LG1
- LTF
- LC1
- LC7
- LC8
- LXF
- LXP**
- LXS
- LC6□
- LZ□
- LC3F2
- X□
- D-□
- E-MY

# Guide Rod Type 2 Phase Stepper Motor Without Motor Brake Series LXP

Ball  
Bushing

Ball Screw  
Ø8 mm/5 mm lead

## How to Order

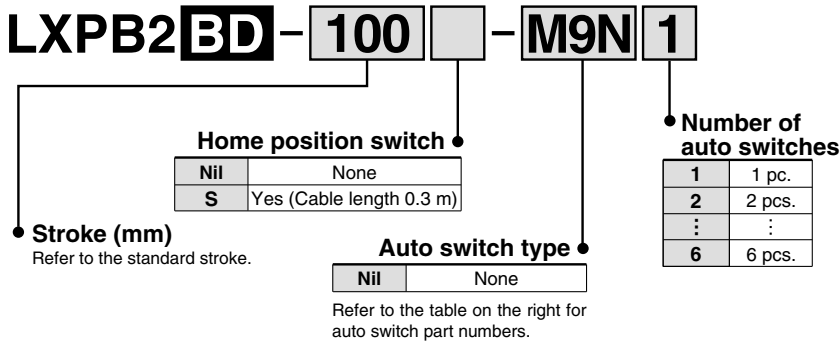

## Auto switch types

Symbol	Model	Wiring/Output type	Lead wire length (m)	Contact
Nil	Without auto switch			
M9N	D-M9N	3 wire/NPN	0.5	N.O. (A contact)
M9P	D-M9P	3 wire/PNP	0.5	N.O. (A contact)
M9B	D-M9B	2 wire	0.5	N.O. (A contact)
F9G	D-F9G	3 wire/NPN	0.5	N.C. (B contact)
F9H	D-F9H	3 wire/PNP	0.5	N.C. (B contact)
F9GL	D-F9GL	3 wire/NPN	3	N.C. (B contact)
F9HL	D-F9HL	3 wire/PNP	3	N.C. (B contact)
M9NL	D-M9NL	3 wire/NPN	3	N.O. (A contact)
M9PL	D-M9PL	3 wire/PNP	3	N.O. (A contact)
M9BL	D-M9BL	2 wire	3	N.O. (A contact)

## Specifications

Standard stroke (mm)		50	75	100	125	150	175	200
Performance	Body mass (kg)	2.0	2.2	2.3	2.6	2.8	2.9	3.1
	Operating temperature range (°C)	5 to 40 (No condensation)						
	Work load (kg)	6 horizontal/5 vertical <sup>Note 1)</sup>						
	Speed (mm/s)	to 80 <sup>Note 2)</sup>						
	Positioning repeatability (mm)	±0.03						
Main parts	Motor	2 phase stepper motor (without brake)						
	Lead screw	Ball screw ø8 mm, 5 mm lead						
	Guide	Ball bushing						
Home position switch	Model	Photo micro sensor EE-SX673 (Refer to page 1084 for details.)						
Driver	Model	LC6D-220AD-□ (Refer to page 964 for details.)						
Positioning driver	Model	LC6C-220AD (Refer to page 967 for details.)						



**Made to order specifications**  
(For details, refer to page 999)

Symbol	Specifications
X20	AC servomotor specification
X60	Low particle generation specification

Note 1) Based on the operating conditions, establish a separate guide when exceeding the maximum allowable lateral load.

Note 2) Since vibration may increase with low speed operation, set the driver to be driven in half-step mode, and use 5 mm/s or more as a guide for speed.

## Operating Conditions

### Allowable lateral load (F)

Stroke	Load (N)
50	42
75	42
100	40
125	42
150	32
175	24
200	17

### Allowable plate rotation torque (T)

Stroke	Torque (N·m)
50	2.87
75	2.47
100	2.17
125	2.38
150	2.16
175	1.98
200	1.82

### Plate non-rotating accuracy (θ)

Non-rotating accuracy
±0.09°

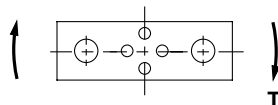
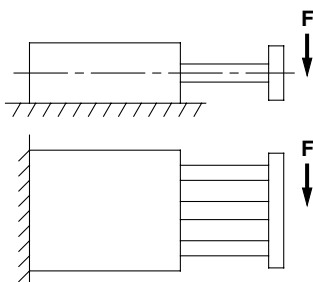
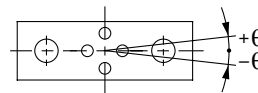

Refer to page 962 for deflection data.

## Dimensions/LXPB2BD

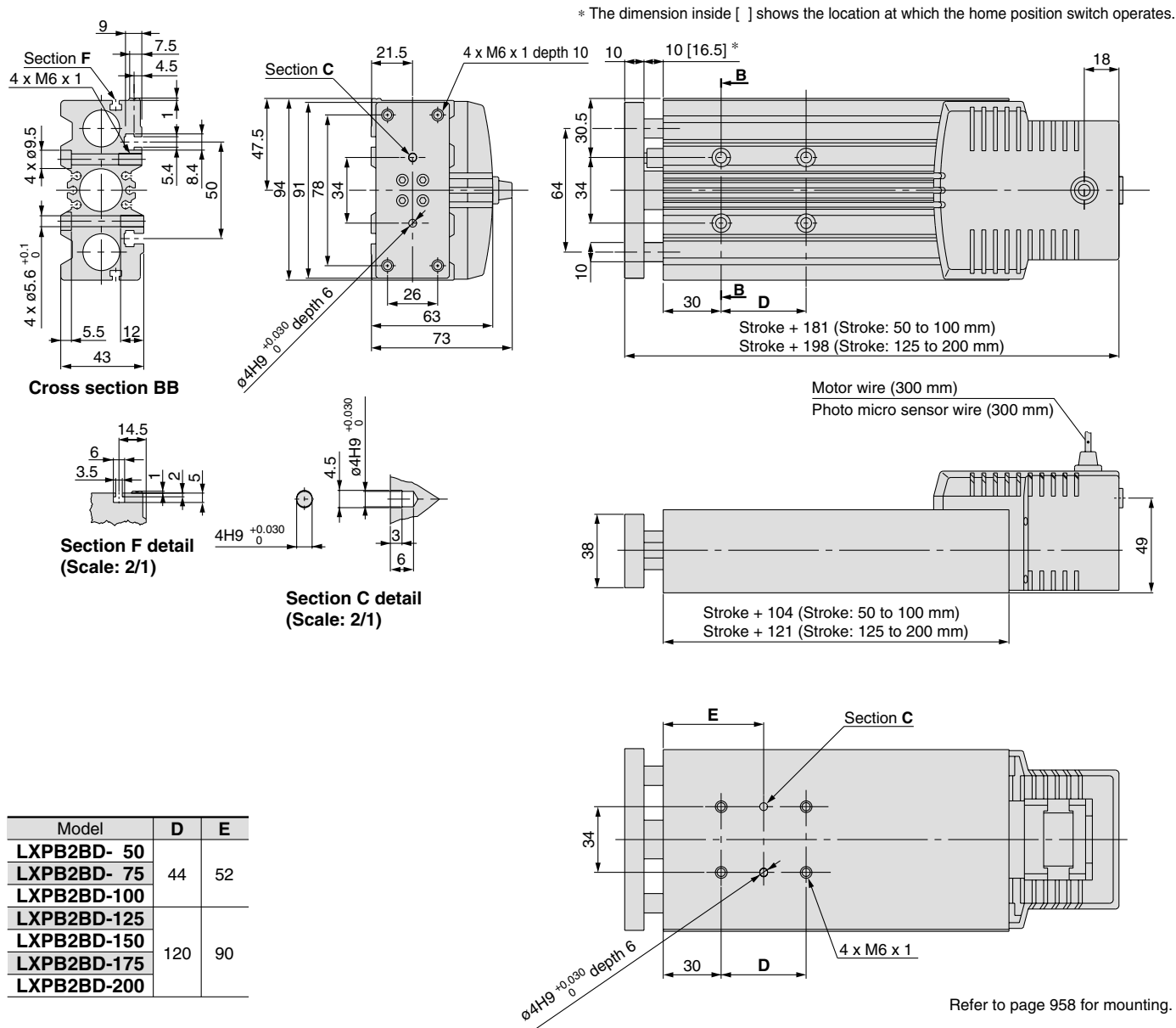

- LJ1
- LG1
- LTF
- LC1
- LC7
- LC8
- LXF
- LXP**
- LXS
- LC6
- LZ
- LC3F2
- X
- D-
- E-MY

## Positioning Time Guide (for Horizontal Mount)

For transfer load of 0 kg

		Positioning time (sec)				
		1	10	50	100	200
Speed (mm/s)	10	0.2	1.1	5.1	10.1	20.1
	40	0.1	0.3	1.3	2.6	5.1
	80	0.1	0.2	0.7	1.3	2.6

For transfer load of 6 kg

		Positioning time (sec)				
		1	10	50	100	200
Speed (mm/s)	10	0.2	1.1	5.1	10.1	20.1
	40	0.1	0.3	1.3	2.6	5.1
	80	0.1	0.2	0.7	1.3	2.6

For transfer load of 3 kg

		Positioning time (sec)				
		1	10	50	100	200
Speed (mm/s)	10	0.2	1.1	5.1	10.1	20.1
	40	0.1	0.3	1.3	2.6	5.1
	80	0.1	0.2	0.7	1.3	2.6

Refer to page 961 for acceleration time.

# Guide Rod Type 2 Phase Stepper Motor Without Motor Brake Series LXP

Ball  
Bushing

Slide Screw  
∅8 mm/6 mm lead

## How to Order

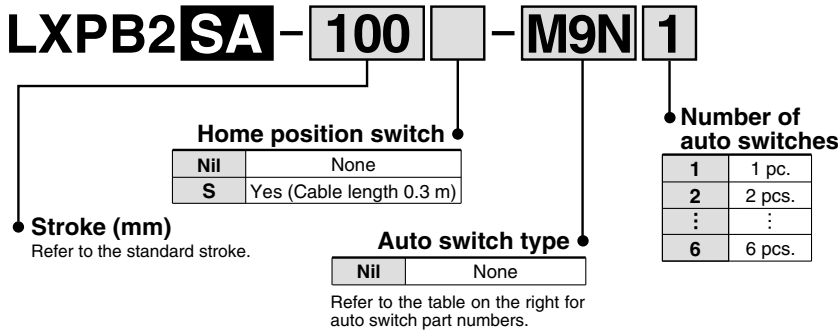

### Auto switch types

Symbol	Model	Wiring/Output type	Lead wire length (m)	Contact
Nil	Without auto switch			
M9N	D-M9N	3 wire/NPN	0.5	N.O. (A contact)
M9P	D-M9P	3 wire/PNP	0.5	N.O. (A contact)
M9B	D-M9B	2 wire	0.5	N.O. (A contact)
F9G	D-F9G	3 wire/NPN	0.5	N.C. (B contact)
F9H	D-F9H	3 wire/PNP	0.5	N.C. (B contact)
F9GL	D-F9GL	3 wire/NPN	3	N.C. (B contact)
F9HL	D-F9HL	3 wire/PNP	3	N.C. (B contact)
M9NL	D-M9NL	3 wire/NPN	3	N.O. (A contact)
M9PL	D-M9PL	3 wire/PNP	3	N.O. (A contact)
M9BL	D-M9BL	2 wire	3	N.O. (A contact)

## Specifications

Standard stroke (mm)		50	75	100	125	150	175	200
Performance	Body mass (kg)	2.0	2.2	2.3	2.6	2.8	2.9	3.1
	Operating temperature range (°C)	5 to 40 (No condensation)						
	Work load (kg)	6 horizontal/5 vertical <sup>Note 1)</sup>						
	Speed (mm/s)	to 100 <sup>Note 2)</sup>						
	Positioning repeatability (mm)	±0.05						
Main parts	Motor	2 phase stepper motor (without brake)						
	Lead screw	Slide screw ∅8 mm, 6 mm lead						
	Guide	Ball bushing						
Home position switch	Model	Photo micro sensor EE-SX673 (Refer to page 1084 for details.)						
Driver	Model	LC6D-220AD-□ (Refer to page 963 for details.)						
Positioning driver	Model	LC6C-220AD (Refer to page 967 for details.)						

Note 1) Based on the operating conditions, establish a separate guide when exceeding the maximum allowable lateral load.

Note 2) Since vibration may increase with low speed operation, set the driver to be driven in half-step mode, and use 6 mm/s or more as a guide for speed.

## Operating Conditions

### Allowable lateral load (F)

Stroke	Load (N)
50	42
75	42
100	40
125	42
150	32
175	24
200	17

### Allowable plate rotation torque (T)

Stroke	Torque (N·m)
50	2.87
75	2.47
100	2.17
125	2.38
150	2.16
175	1.98
200	1.82

### Plate non-rotating accuracy (θ)

Non-rotating accuracy
±0.09°

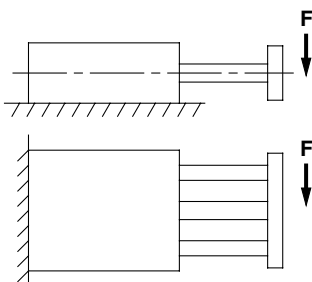
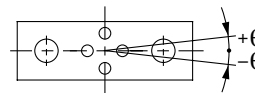

Refer to page 962 for deflection data.



## Dimensions/LXPB2SA

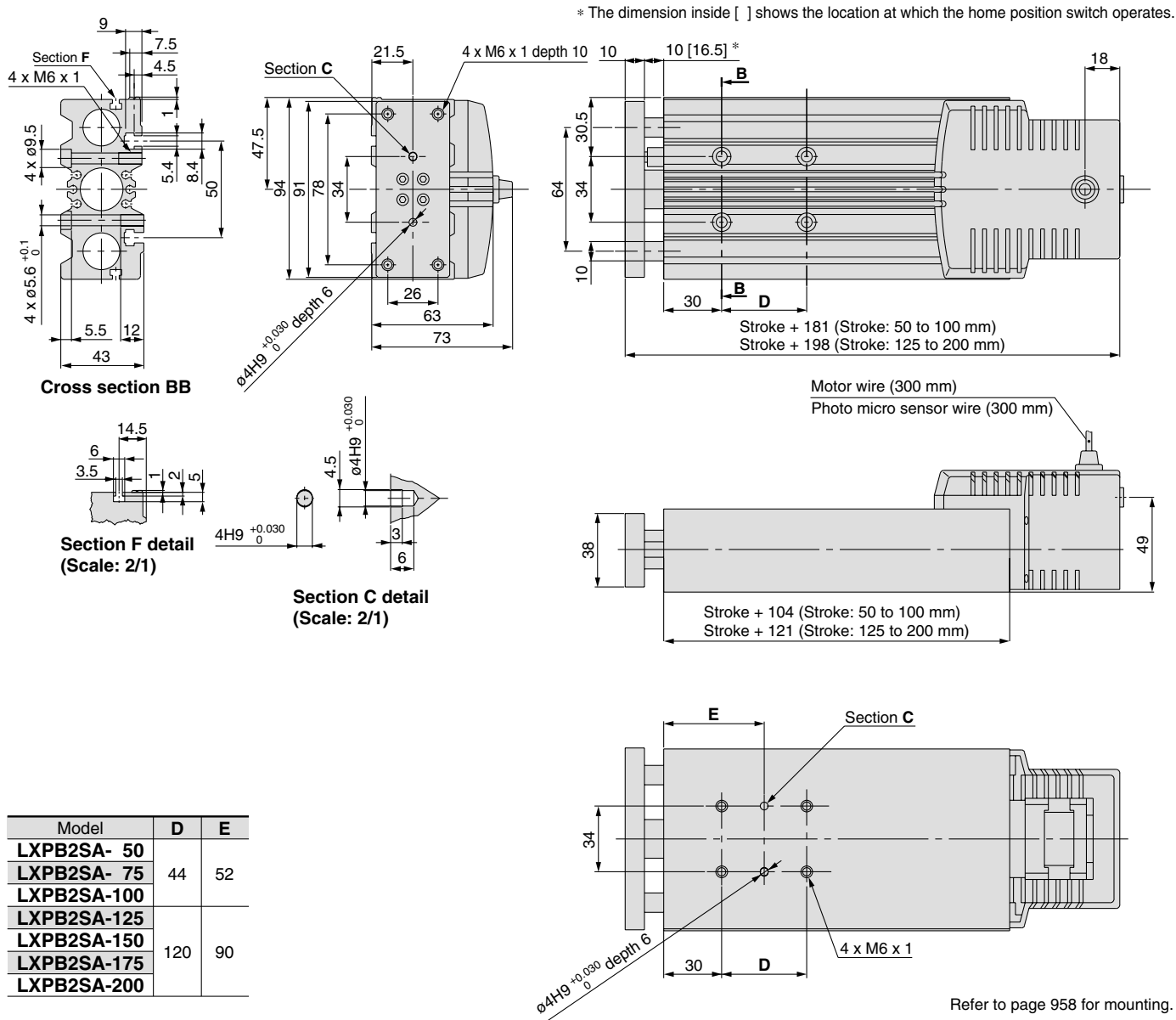

Refer to page 958 for mounting.

## Positioning Time Guide (for Horizontal Mount)

For transfer load of 0 kg

		Positioning time (sec)				
		1	10	50	100	200
Speed (mm/s)	10	0.2	1.1	5.1	10.1	20.1
	50	0.1	0.3	1.1	2.1	4.1
	100	0.1	0.2	0.6	1.1	2.1

For transfer load of 6 kg

		Positioning time (sec)				
		1	10	50	100	200
Speed (mm/s)	10	0.1	1.1	5.1	10.1	20.1
	50	0.1	0.3	1.1	2.1	4.1
	100	0.1	0.2	0.6	1.1	2.1

For transfer load of 3 kg

		Positioning time (sec)				
		1	10	50	100	200
Speed (mm/s)	10	0.2	1.1	5.1	10.1	20.1
	50	0.1	0.3	1.1	2.1	4.1
	100	0.1	0.2	0.6	1.1	2.1

Refer to page 960 for acceleration time.

- LJ1
- LG1
- LTF
- LC1
- LC7
- LC8
- LXF
- LXP**
- LXS
- LC6□
- LZ□
- LC3F2
- X□
- D-□
- E-MY

# Guide Rod Type 2 Phase Stepper Motor Without Motor Brake Series LXP

Ball  
Bushing

Slide Screw  
ø8 mm/12 mm lead

## How to Order

**LXPB2SB** - **100** - **M9N** **1**

**Home position switch**

Nil	None
S	Yes (Cable length 0.3 m)

**Stroke (mm)**  
Refer to the standard stroke.

**Auto switch type**

Nil	None
-----	------

Refer to the table on the right for auto switch part numbers.

**Number of auto switches**

1	1 pc.
2	2 pcs.
⋮	⋮
6	6 pcs.

### Auto switch types

Symbol	Model	Wiring/Output type	Lead wire length (m)	Contact
Nil	Without auto switch			
M9N	D-M9N	3 wire/NPN	0.5	N.O. (A contact)
M9P	D-M9P	3 wire/PNP	0.5	N.O. (A contact)
M9B	D-M9B	2 wire	0.5	N.O. (A contact)
F9G	D-F9G	3 wire/NPN	0.5	N.C. (B contact)
F9H	D-F9H	3 wire/PNP	0.5	N.C. (B contact)
F9GL	D-F9GL	3 wire/NPN	3	N.C. (B contact)
F9HL	D-F9HL	3 wire/PNP	3	N.C. (B contact)
M9NL	D-M9NL	3 wire/NPN	3	N.O. (A contact)
M9PL	D-M9PL	3 wire/PNP	3	N.O. (A contact)
M9BL	D-M9BL	2 wire	3	N.O. (A contact)

## Specifications

Standard stroke (mm)		50	75	100	125	150	175	200
Performance	Body mass (kg)	2.0	2.2	2.3	2.6	2.8	2.9	3.1
	Operating temperature range (°C)	5 to 40 (No condensation)						
	Work load (kg)	3 horizontal/3 vertical <sup>Note 1)</sup>						
	Speed (mm/s)	to 200 <sup>Note 2)</sup>						
	Positioning repeatability (mm)	±0.05						
Main parts	Motor	2 phase stepper motor (without brake)						
	Lead screw	Slide screw ø8 mm, 12 mm lead						
	Guide	Ball bushing						
Home position switch	Model	Photo micro sensor EE-SX673 (Refer to page 1084 for details.)						
Driver	Model	LC6D-220AD-□ (Refer to page 963 for details.)						
Positioning driver	Model	LC6C-220AD (Refer to page 967 for details.)						

Note 1) Based on the operating conditions, establish a separate guide when exceeding the maximum allowable lateral load.

Note 2) Since vibration may increase with low speed operation, set the driver to be driven in half-step mode, and use 12 mm/s or more as a guide for speed.

## Operating Conditions

### Allowable lateral load (F)

Stroke	Load (N)
50	42
75	42
100	40
125	42
150	32
175	24
200	17

### Allowable plate rotation torque (T)

Stroke	Torque (N·m)
50	2.87
75	2.47
100	2.17
125	2.38
150	2.16
175	1.98
200	1.82

### Plate non-rotating accuracy (θ)

Non-rotating accuracy
±0.09°

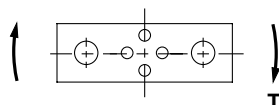
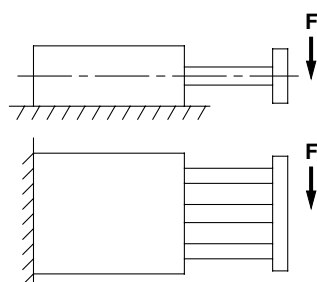
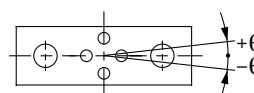

Refer to page 962 for deflection data.

## Dimensions/LXPB2SB

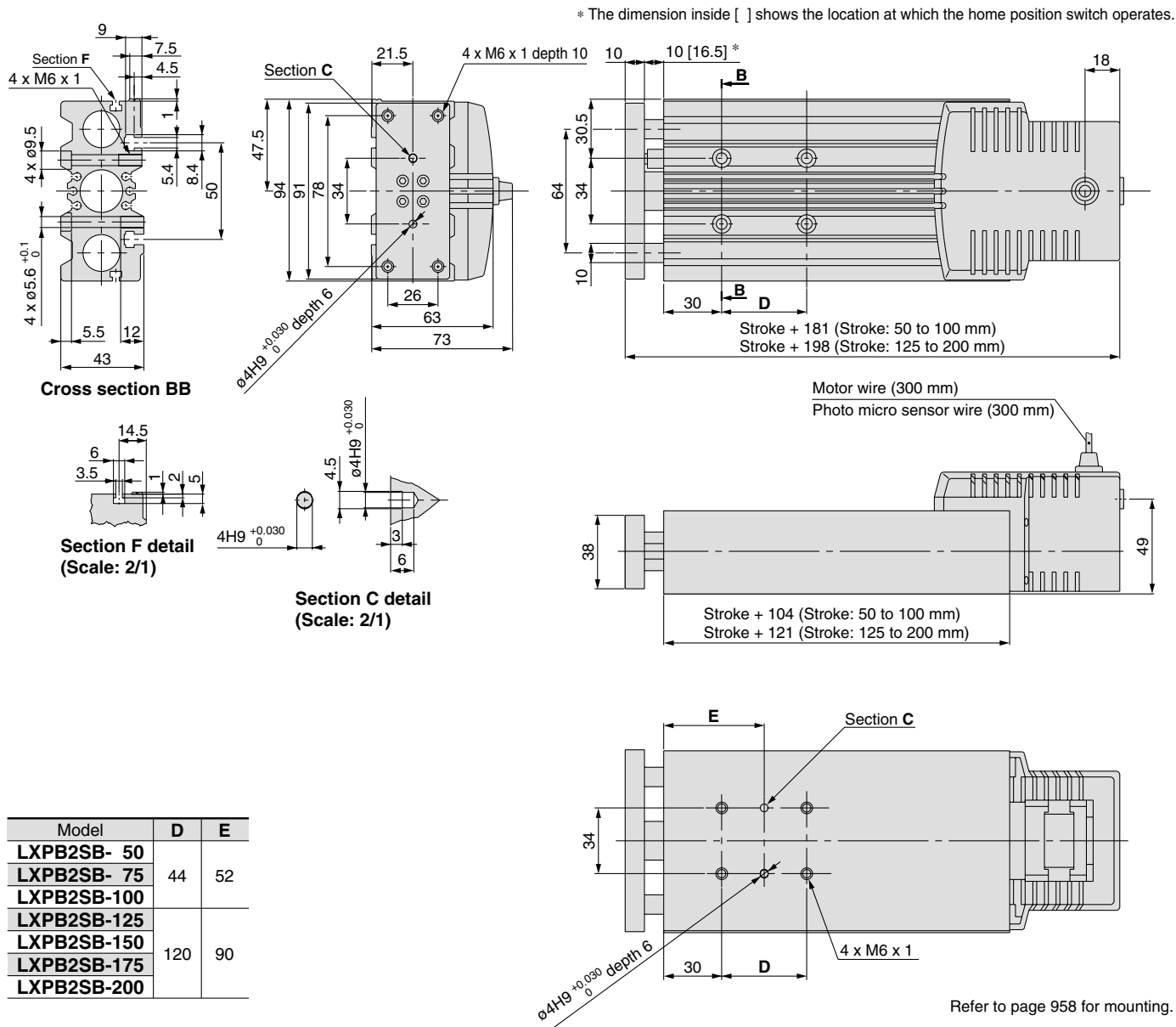

- LJ1
- LG1
- LTF
- LC1
- LC7
- LC8
- LXF
- LXP**
- LXS
- LC6□
- LZ□
- LC3F2
- X□
- D-□
- E-MY

## Positioning Time Guide (for Horizontal Mount)

For transfer load of 0 kg

		Positioning time (sec)				
		1	10	50	100	200
Speed (mm/s)	50	0.1	0.3	1.1	2.1	4.2
	100	0.1	0.2	0.6	1.1	2.1
	200	0.1	0.1	0.3	0.6	1.1

For transfer load of 3 kg

		Positioning time (sec)				
		1	10	50	100	200
Speed (mm/s)	50	0.1	0.3	1.1	2.1	4.1
	100	0.1	0.2	0.6	1.1	2.1
	200	0.1	0.1	0.3	0.6	1.1

For transfer load of 1.5 kg

		Positioning time (sec)				
		1	10	50	100	200
Speed (mm/s)	50	0.1	0.3	1.1	2.1	4.1
	100	0.1	0.2	0.6	1.1	2.1
	200	0.1	0.1	0.3	0.6	1.1

Refer to page 960 for acceleration time.

# Guide Rod Type 2 Phase Stepper Motor With Motor Brake Series LXP

Ball Bushing

Ball Screw  
∅ 8 mm / 2 mm lead

## How to Order

**LXPB2BC-100 B-M9N 1**

**Home position switch**

Nil	None
S	Yes (Cable length 0.3 m)

**Stroke (mm)**  
Refer to the standard stroke.

**Auto switch type**

Nil	None
-----	------

Refer to the table on the right for auto switch part numbers.

**Number of auto switches**

1	1 pc.
2	2 pcs.
⋮	⋮
6	6 pcs.

## Specifications

Standard stroke (mm)		50	75	100	125	150	175	200	
Performance	Body mass (kg)	2.2	2.4	2.5	2.8	3.0	3.1	3.3	
	Operating temperature range (°C)	5 to 40 (No condensation)							
	Work load (kg)	6 horizontal/5 vertical <sup>Note 1)</sup>							
	Speed (mm/s)	to 30 <sup>Note 2)</sup>							
	Positioning repeatability (mm)	±0.03							
Main parts	Motor	2 phase stepper motor (with brake)							
	Lead screw	Ball screw ∅8 mm, 2 mm lead							
	Guide	Ball bushing							
	Electromagnetic brake	Model	De-energized operating type						
		Static torque (N·m)	0.1 or more						
Rated voltage (V)		24 DC ±5%							
	Power consumption (W)	5							
Home position switch	Model	Photo micro sensor EE-SX673 (Refer to page 1084 for details.)							
Driver	Model	LC6D-220AD-□ (Refer to page 963 for details.)							
Positioning driver	Model	LC6C-220AD (Refer to page 967 for details.)							

## Auto switch types

Symbol	Model	Wiring/Output type	Lead wire length (m)	Contact
Nil	Without auto switch			
M9N	D-M9N	3 wire/NPN	0.5	N.O. (A contact)
M9P	D-M9P	3 wire/PNP	0.5	N.O. (A contact)
M9B	D-M9B	2 wire	0.5	N.O. (A contact)
F9G	D-F9G	3 wire/NPN	0.5	N.C. (B contact)
F9H	D-F9H	3 wire/PNP	0.5	N.C. (B contact)
F9GL	D-F9GL	3 wire/NPN	3	N.C. (B contact)
F9HL	D-F9HL	3 wire/PNP	3	N.C. (B contact)
M9NL	D-M9NL	3 wire/NPN	3	N.O. (A contact)
M9PL	D-M9PL	3 wire/PNP	3	N.O. (A contact)
M9BL	D-M9BL	2 wire	3	N.O. (A contact)



## Made to order specifications (For details, refer to page 999)

Symbol	Specifications
X20	AC servomotor specification
X60	Low particle generation specification

Note 1) Based on the operating conditions, establish a separate guide when exceeding the maximum allowable lateral load.

Note 2) Since vibration may increase with low speed operation, set the driver to be driven in half-step mode, and use 2 mm/s or more as a guide for speed.

## Lifter Operation Range

This is the operating range for ball bushings. Use within the allowable thrust range.

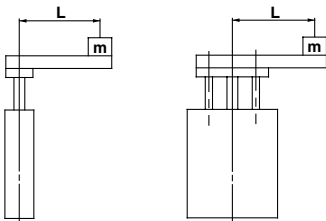

### 50 to 200 mm stroke

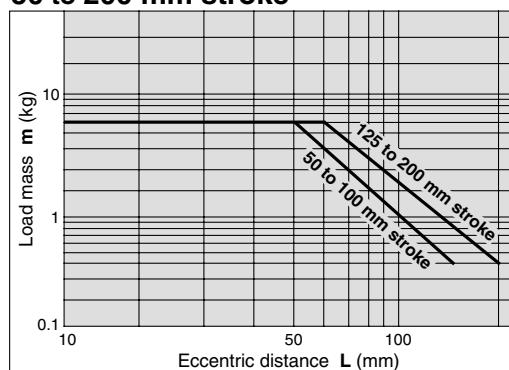

## Operating Conditions

### Allowable lateral load (F)

Stroke	Load (N)
50	42
75	42
100	40
125	42
150	32
175	24
200	17

### Allowable plate rotation torque (T)

Stroke	Torque (N·m)
50	2.87
75	2.47
100	2.17
125	2.38
150	2.16
175	1.98
200	1.82

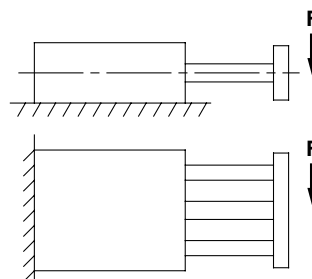

### Plate non-rotating accuracy (θ)

Non-rotating accuracy
±0.09°

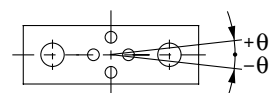

Refer to page 962 for deflection data.

## Dimensions/LXPB2BC

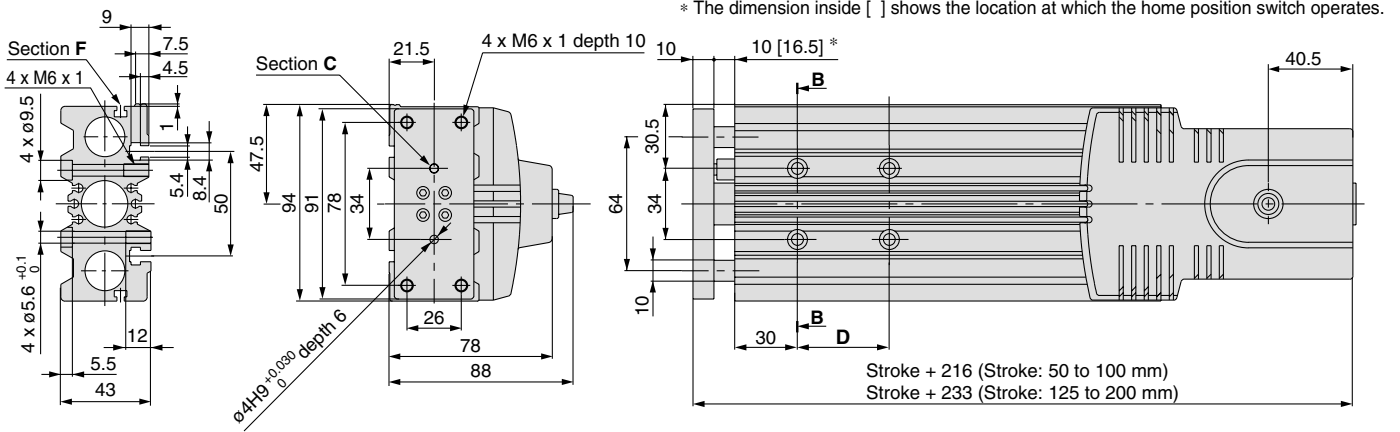

Cross section BB

### Brake electrical circuit

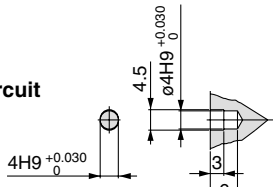
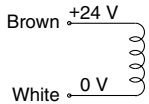

Section C detail  
(Scale: 2/1)

Motor wire (300 mm)  
Brake wire (300 mm)  
Photo micro sensor wire (300 mm)

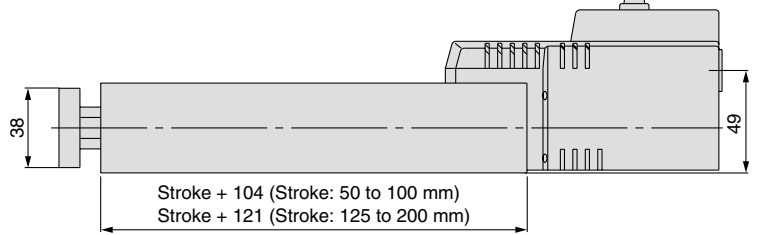

Note) A contact protection circuit is required when connecting a brake.

Model	D	E
LXPB2BC- 50	44	52
LXPB2BC- 75		
LXPB2BC-100		
LXPB2BC-125	120	90
LXPB2BC-150		
LXPB2BC-175		
LXPB2BC-200		

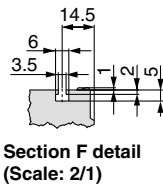

Section F detail  
(Scale: 2/1)

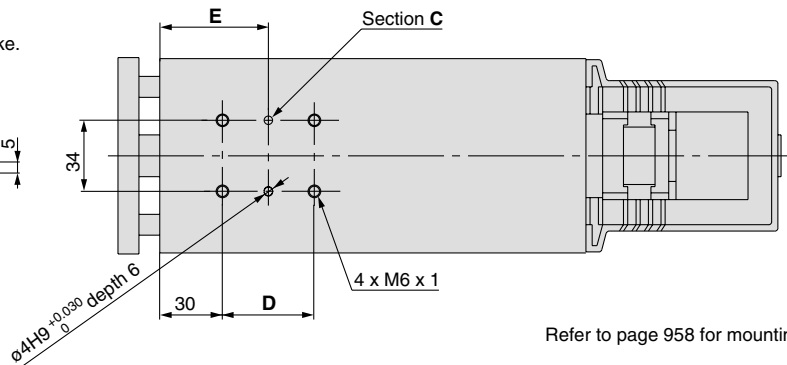

Refer to page 958 for mounting.

## Positioning Time Guide (for Vertical Mount)

### For transfer load of 0 kg

Positioning distance (mm)		Positioning time (sec)				
		1	10	50	100	200
Speed (mm/s)	10	0.2	1.1	5.1	10.1	20.1
	20	0.1	0.6	2.6	5.1	10.1
	30	0.1	0.4	1.7	3.4	6.7

### For transfer load of 5 kg

Positioning distance (mm)		Positioning time (sec)				
		1	10	50	100	200
Speed (mm/s)	10	0.2	1.1	5.1	10.1	20.1
	20	0.1	0.6	2.6	5.1	10.1
	30	0.1	0.4	1.7	3.4	6.7

### For transfer load of 2.5 kg

Positioning distance (mm)		Positioning time (sec)				
		1	10	50	100	200
Speed (mm/s)	10	0.2	1.1	5.1	10.1	20.1
	20	0.1	0.6	2.6	5.1	10.1
	30	0.1	0.4	1.7	3.4	6.7

Refer to page 961 for acceleration time.

- LJ1
- LG1
- LTF
- LC1
- LC7
- LC8
- LXF
- LXP
- LXS
- LC6
- LZ
- LC3F2
- X
- D-
- E-MY

# Guide Rod Type 2 Phase Stepper Motor With Motor Brake Series LXP

Ball  
Bushing

Ball Screw  
Ø 8 mm/5 mm lead

## How to Order

**LXPB2BD-100 B-M9N 1**

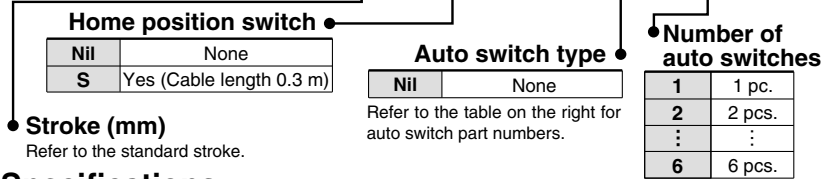

## Specifications

Standard stroke (mm)		50	75	100	125	150	175	200	
Performance	Body mass (kg)	2.2	2.4	2.5	2.8	3.0	3.1	3.3	
	Operating temperature range (°C)	5 to 40 (No condensation)							
	Work load (kg)	6 horizontal/5 vertical <sup>Note 1)</sup>							
	Speed (mm/s)	to 80 <sup>Note 2)</sup>							
	Positioning repeatability (mm)	±0.03							
Main parts	Motor	2 phase stepper motor (with brake)							
	Lead screw	Ball screw ø8 mm, 5 mm lead							
	Guide	Ball bushing							
	Electromagnetic brake	Model	De-energized operating type						
		Static torque (N·m)	0.1 or more						
Rated voltage (V)		24 DC ±5%							
	Power consumption (W)	5							
Home position switch	Model	Photo micro sensor EE-SX673 (Refer to page 1084 for details.)							
Driver	Model	LC6D-220AD-□ (Refer to page 963 for details.)							
Positioning driver	Model	LC6C-220AD (Refer to page 967 for details.)							

## Auto switch types

Symbol	Model	Wiring/Output type	Lead wire length (m)	Contact
Nil	Without auto switch			
M9N	D-M9N	3 wire/NPN	0.5	N.O. (A contact)
M9P	D-M9P	3 wire/PNP	0.5	N.O. (A contact)
M9B	D-M9B	2 wire	0.5	N.O. (A contact)
F9G	D-F9G	3 wire/NPN	0.5	N.C. (B contact)
F9H	D-F9H	3 wire/PNP	0.5	N.C. (B contact)
F9GL	D-F9GL	3 wire/NPN	3	N.C. (B contact)
F9HL	D-F9HL	3 wire/PNP	3	N.C. (B contact)
M9NL	D-M9NL	3 wire/NPN	3	N.O. (A contact)
M9PL	D-M9PL	3 wire/PNP	3	N.O. (A contact)
M9BL	D-M9BL	2 wire	3	N.O. (A contact)



**Made to order specifications**  
(For details, refer to page 999)

Symbol	Specifications
X20	AC servomotor specification
X60	Low particle generation specification

Note 1) Based on the operating conditions, establish a separate guide when exceeding the maximum allowable lateral load.

Note 2) Since vibration may increase with low speed operation, set the driver to be driven in half-step mode, and use 5 mm/s or more as a guide for speed.

## Lifter Operation Range

This is the operating range for ball bushings. Use within the allowable thrust range.

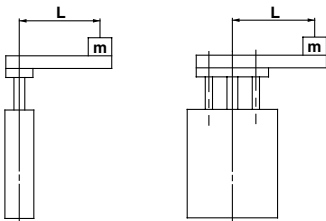

### 50 to 200 mm stroke

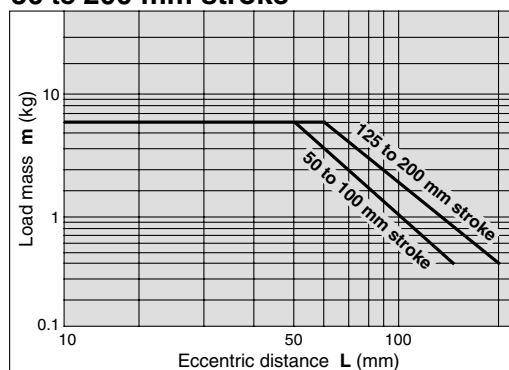

## Operating Conditions

### Allowable lateral load (F)

Stroke	Load (N)
50	42
75	42
100	40
125	42
150	32
175	24
200	17

### Allowable plate rotation torque (T)

Stroke	Torque (N·m)
50	2.87
75	2.47
100	2.17
125	2.38
150	2.16
175	1.98
200	1.82

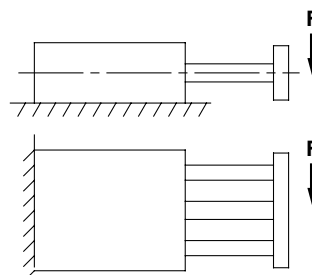

### Plate non-rotating accuracy (θ)

Non-rotating accuracy
±0.09°

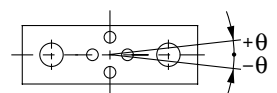

Refer to page 962 for deflection data.



## Dimensions/LXPB2BD

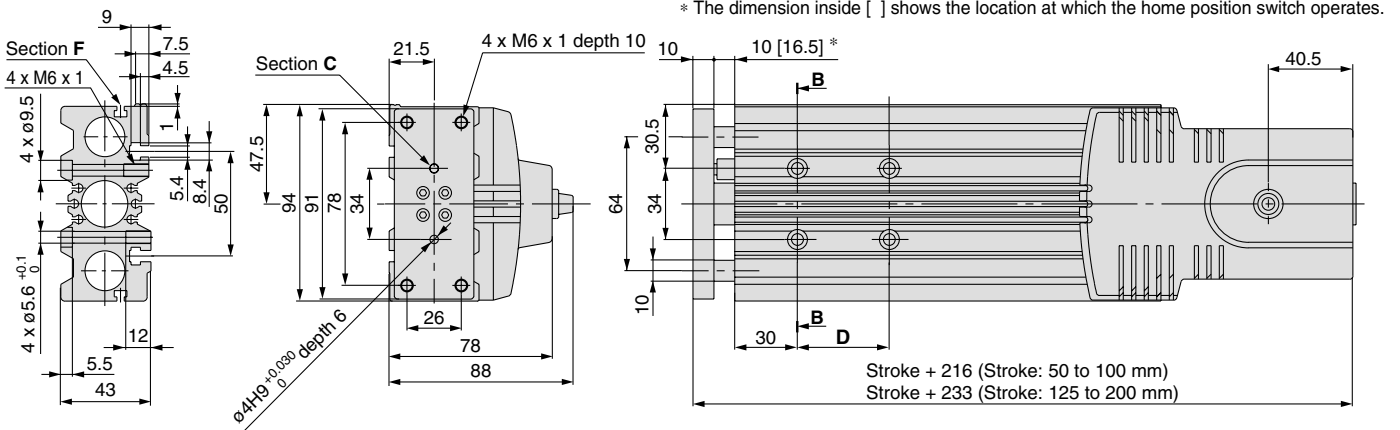

**Cross section BB**

### Brake electrical circuit

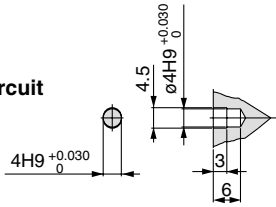
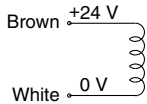

**Section C detail  
(Scale: 2/1)**

Motor wire (300 mm)  
Brake wire (300 mm)  
Photo micro sensor wire (300 mm)

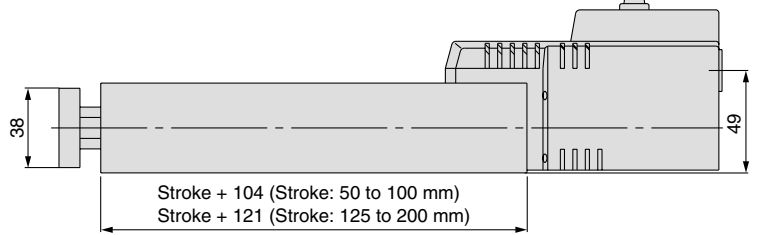

Note) A contact protection circuit is required when connecting a brake.

Model	D	E
LXPB2BD- 50	44	52
LXPB2BD- 75		
LXPB2BD-100		
LXPB2BD-125	120	90
LXPB2BD-150		
LXPB2BD-175		
LXPB2BD-200		

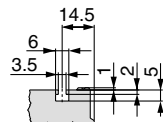

**Section F detail  
(Scale: 2/1)**

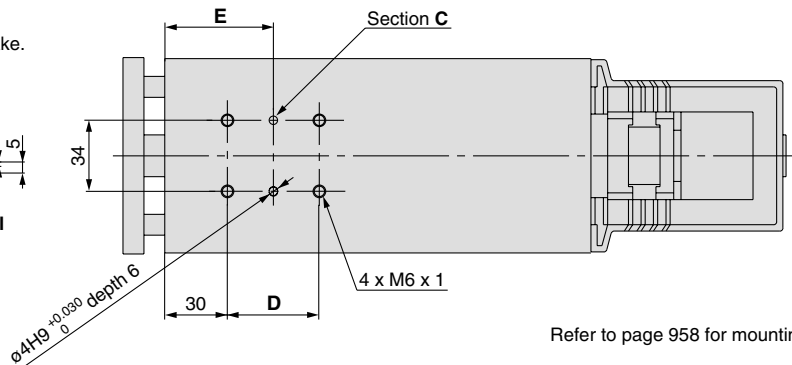

Refer to page 958 for mounting.

## Positioning Time Guide (for Vertical Mount)

### For transfer load of 0 kg

Positioning distance (mm)		Positioning time (sec)				
		1	10	50	100	200
Speed (mm/s)	10	0.2	1.1	5.1	10.1	20.1
	40	0.1	0.3	1.3	2.6	5.1
	80	0.1	0.2	0.7	1.3	2.6

### For transfer load of 5 kg

Positioning distance (mm)		Positioning time (sec)				
		1	10	50	100	200
Speed (mm/s)	10	0.2	1.1	5.1	10.1	20.1
	40	0.1	0.3	1.3	2.6	5.1
	80	0.1	0.2	0.7	1.3	2.6

### For transfer load of 2.5 kg

Positioning distance (mm)		Positioning time (sec)				
		1	10	50	100	200
Speed (mm/s)	10	0.2	1.1	5.1	10.1	20.1
	40	0.1	0.3	1.3	2.6	5.1
	80	0.1	0.2	0.7	1.3	2.6

Refer to page 961 for acceleration time.

- LJ1
- LG1
- LTF
- LC1
- LC7
- LC8
- LXF
- LXP
- LXS
- LC6
- LZ
- LC3F2
- X
- D-
- E-MY

# Guide Rod Type 2 Phase Stepper Motor With Motor Brake Series LXP

Ball  
Bushing

Slide Screw  
Ø 8 mm/6 mm lead

## How to Order

**LXPB2 SA - 100 B - M9N 1**

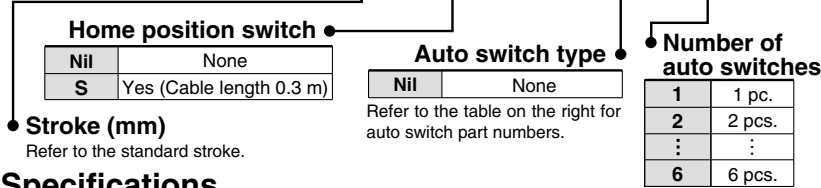

## Specifications

Standard stroke (mm)		50	75	100	125	150	175	200	
<b>Performance</b>	Body mass (kg)	2.2	2.4	2.5	2.8	3.0	3.1	3.3	
	Operating temperature range (°C)	5 to 40 (No condensation)							
	Work load (kg)	6 horizontal/5 vertical <sup>Note 1)</sup>							
	Speed (mm/s)	to 100 <sup>Note 2)</sup>							
	Positioning repeatability (mm)	±0.05							
<b>Main parts</b>	Motor	2 phase stepper motor (with brake)							
	Lead screw	Slide screw ø8 mm, 6 mm lead							
	Guide	Ball bushing							
	Electromagnetic brake	Model	De-energized operating type						
		Static torque (N·m)	0.1 or more						
Rated voltage (V)		24 DC ±5%							
	Power consumption (W)	5							
<b>Home position switch</b>	Model	Photo micro sensor EE-SX673 (Refer to page 1084 for details.)							
<b>Driver</b>	Model	LC6D-220AD-□ (Refer to page 963 for details.)							
<b>Positioning driver</b>	Model	LC6C-220AD (Refer to page 967 for details.)							

## Auto switch types

Symbol	Model	Wiring/Output type	Lead wire length (m)	Contact
Nil	Without auto switch			
M9N	D-M9N	3 wire/NPN	0.5	N.O. (A contact)
M9P	D-M9P	3 wire/PNP	0.5	N.O. (A contact)
M9B	D-M9B	2 wire	0.5	N.O. (A contact)
F9G	D-F9G	3 wire/NPN	0.5	N.C. (B contact)
F9H	D-F9H	3 wire/PNP	0.5	N.C. (B contact)
F9GL	D-F9GL	3 wire/NPN	3	N.C. (B contact)
F9HL	D-F9HL	3 wire/PNP	3	N.C. (B contact)
M9NL	D-M9NL	3 wire/NPN	3	N.O. (A contact)
M9PL	D-M9PL	3 wire/PNP	3	N.O. (A contact)
M9BL	D-M9BL	2 wire	3	N.O. (A contact)

Note 1) Based on the operating conditions, establish a separate guide when exceeding the maximum allowable lateral load.

Note 2) Since vibration may increase with low speed operation, set the driver to be driven in half-step mode, and use 6 mm/s or more as a guide for speed.

## Lifter Operation Range

This is the operating range for ball bushings. Use within the allowable thrust range.

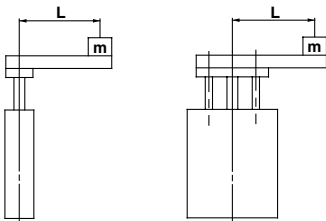

### 50 to 200 mm stroke

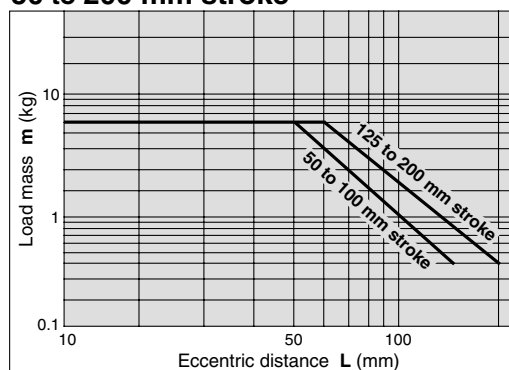

## Operating Conditions

### Allowable lateral load (F)

Stroke	Load (N)
50	42
75	42
100	40
125	42
150	32
175	24
200	17

### Allowable plate rotation torque (T)

Stroke	Torque (N·m)
50	2.87
75	2.47
100	2.17
125	2.38
150	2.16
175	1.98
200	1.82

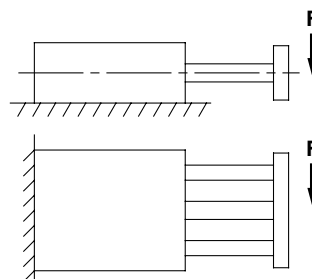

### Plate non-rotating accuracy (θ)

Non-rotating accuracy  
±0.09°

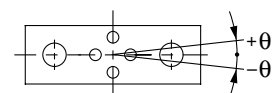

Refer to page 962 for deflection data.

## Dimensions/LXPB2SA

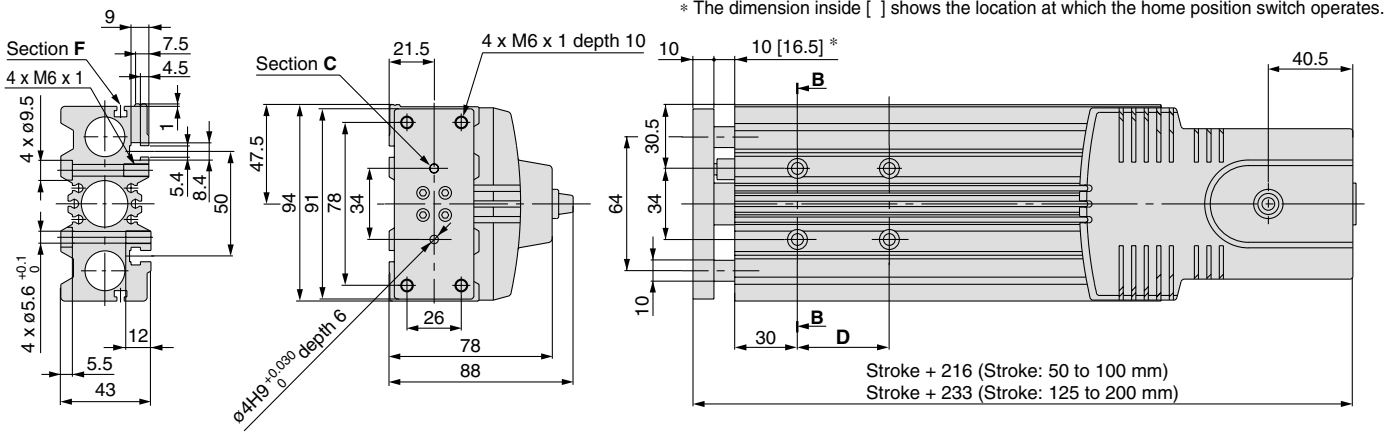

**Cross section BB**

### Brake electrical circuit

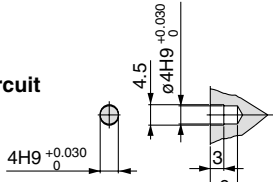
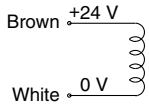

**Section C detail  
(Scale: 2/1)**

Motor wire (300 mm)  
Brake wire (300 mm)  
Photo micro sensor wire (300 mm)

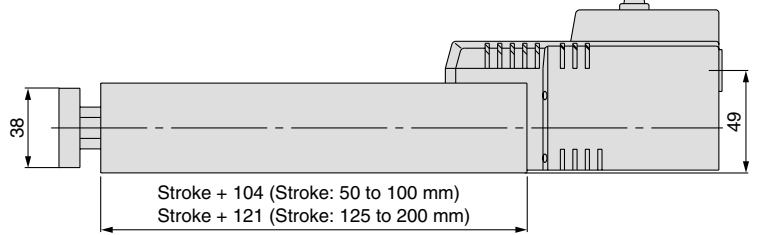

Note) A contact protection circuit is required when connecting a brake.

Model	D	E
LXPB2SA- 50	44	52
LXPB2SA- 75		
LXPB2SA-100		
LXPB2SA-125	120	90
LXPB2SA-150		
LXPB2SA-175		
LXPB2SA-200		

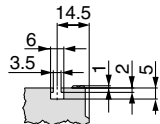

**Section F detail  
(Scale: 2/1)**

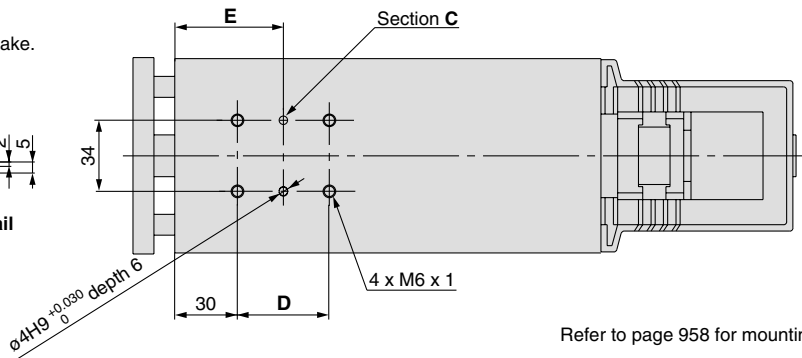

## Positioning Time Guide (for Vertical Mount)

### For transfer load of 0 kg

Positioning distance (mm)		Positioning time (sec)				
		1	10	50	100	200
Speed (mm/s)	10	0.2	1.1	5.1	10.1	20.1
	50	0.1	0.3	1.1	2.1	4.1
	100	0.1	0.2	0.6	1.1	2.1

### For transfer load of 5 kg

Positioning distance (mm)		Positioning time (sec)				
		1	10	50	100	200
Speed (mm/s)	10	0.2	1.1	5.1	10.1	20.1
	50	0.1	0.3	1.1	2.1	4.1
	100	0.1	0.2	0.6	1.1	2.1

### For transfer load of 2.5 kg

Positioning distance (mm)		Positioning time (sec)				
		1	10	50	100	200
Speed (mm/s)	10	0.2	1.1	5.1	10.1	20.1
	50	0.1	0.3	1.1	2.1	4.1
	100	0.1	0.2	0.6	1.1	2.1

Refer to page 960 for acceleration time.

- LJ1
- LG1
- LTF
- LC1
- LC7
- LC8
- LXF
- LXP
- LXS
- LC6
- LZ
- LC3F2
- X
- D-
- E-MY

# Guide Rod Type 2 Phase Stepper Motor With Motor Brake Series LXP

Ball  
Bushing

Slide Screw  
Ø 8 mm/12 mm lead

## How to Order

LXPB2 **SB** - **100** **B** - **M9N** **1**

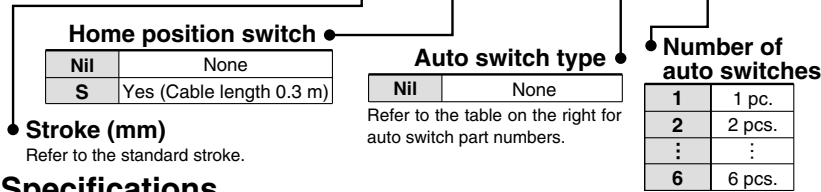

## Specifications

Standard stroke (mm)		50	75	100	125	150	175	200	
Performance	Body mass (kg)	2.2	2.4	2.5	2.8	3.0	3.1	3.3	
	Operating temperature range (°C)	5 to 40 (No condensation)							
	Work load (kg)	3 horizontal/3 vertical <sup>Note 1)</sup>							
	Speed (mm/s)	to 200 <sup>Note 2)</sup>							
	Positioning repeatability (mm)	±0.05							
Main parts	Motor	2 phase stepper motor (with brake)							
	Lead screw	Slide screw ø8 mm, 12 mm lead							
	Guide	Ball bushing							
	Electromagnetic brake	Model	De-energized operating type						
		Static torque (N-m)	0.1 or more						
Rated voltage (V)		24 DC ±5%							
	Power consumption (W)	5							
Home position switch	Model	Photo micro sensor EE-SX673 (Refer to page 1084 for details.)							
Driver	Model	LC6D-220AD-□ (Refer to page 963 for details.)							
Positioning driver	Model	LC6C-220AD (Refer to page 967 for details.)							

## Auto switch types

Symbol	Model	Wiring/Output type	Lead wire length (m)	Contact
Nil	Without auto switch			
M9N	D-M9N	3 wire/NPN	0.5	N.O. (A contact)
M9P	D-M9P	3 wire/PNP	0.5	N.O. (A contact)
M9B	D-M9B	2 wire	0.5	N.O. (A contact)
F9G	D-F9G	3 wire/NPN	0.5	N.C. (B contact)
F9H	D-F9H	3 wire/PNP	0.5	N.C. (B contact)
F9GL	D-F9GL	3 wire/NPN	3	N.C. (B contact)
F9HL	D-F9HL	3 wire/PNP	3	N.C. (B contact)
M9NL	D-M9NL	3 wire/NPN	3	N.O. (A contact)
M9PL	D-M9PL	3 wire/PNP	3	N.O. (A contact)
M9BL	D-M9BL	2 wire	3	N.O. (A contact)

Note 1) Based on the operating conditions, establish a separate guide when exceeding the maximum allowable lateral load.

Note 2) Since vibration may increase with low speed operation, set the driver to be driven in half-step mode, and use 12 mm/s or more as a guide for speed.

## Lifter Operation Range

This is the operating range for ball bushings. Use within the allowable thrust range.

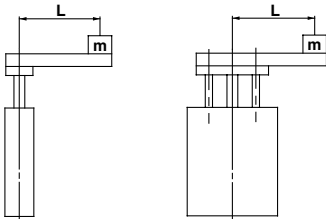

### 50 to 200 mm stroke

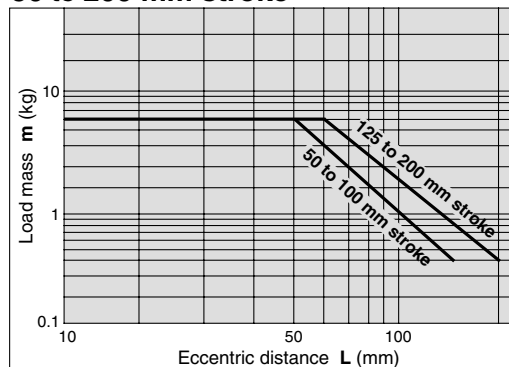

## Operating Conditions

### Allowable lateral load (F)

Stroke	Load (N)
50	42
75	42
100	40
125	42
150	32
175	24
200	17

### Allowable plate rotation torque (T)

Stroke	Torque (N-m)
50	2.87
75	2.47
100	2.17
125	2.38
150	2.16
175	1.98
200	1.82

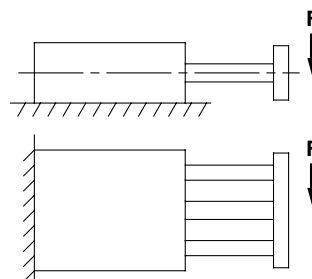

### Plate non-rotating accuracy (θ)

Non-rotating accuracy  
±0.09°

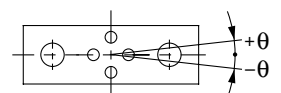

Refer to page 962 for deflection data.

## Dimensions/LXPB2SB

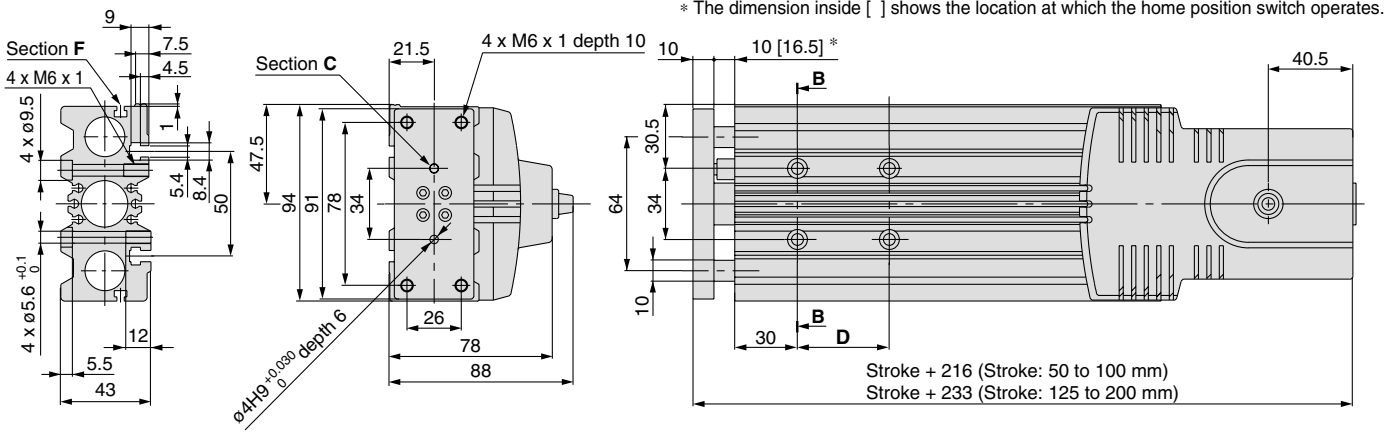

Cross section BB

### Brake electrical circuit

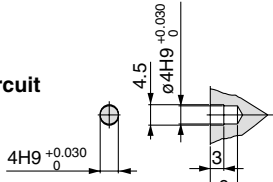
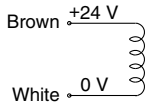

Section C detail  
(Scale: 2/1)

Motor wire (300 mm)  
Brake wire (300 mm)  
Photo micro sensor wire (300 mm)

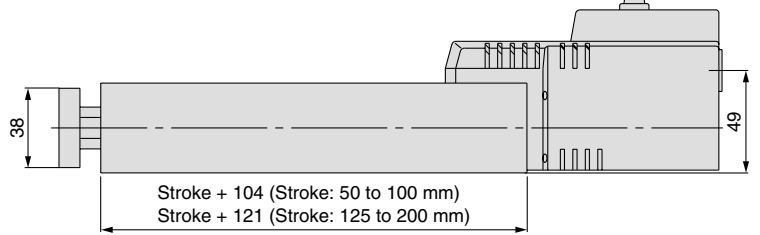

Note) A contact protection circuit is required when connecting a brake.

Model	D	E
LXPB2SB- 50	44	52
LXPB2SB- 75		
LXPB2SB-100		
LXPB2SB-125	120	90
LXPB2SB-150		
LXPB2SB-175		
LXPB2SB-200		

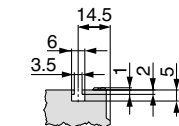

Section F detail  
(Scale: 2/1)

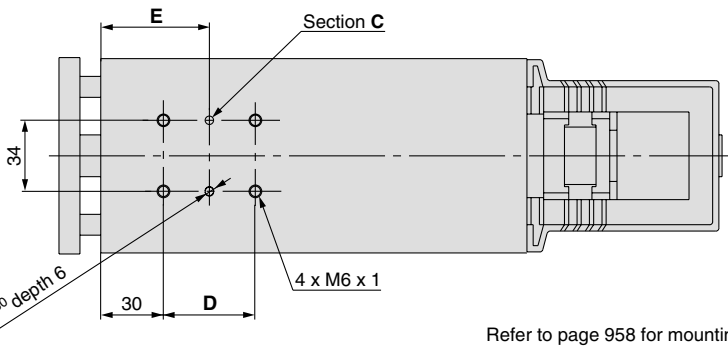

Refer to page 958 for mounting.

## Positioning Time Guide (for Vertical Mount)

### For transfer load of 0 kg

Positioning distance (mm)		Positioning time (sec)				
		1	10	50	100	200
Speed (mm/s)	50	0.1	0.3	1.1	2.1	4.1
	100	0.1	0.2	0.6	1.1	2.1
	200	0.1	0.1	0.3	0.6	1.1

### For transfer load of 3 kg

Positioning distance (mm)		Positioning time (sec)				
		1	10	50	100	200
Speed (mm/s)	50	0.1	0.3	1.1	2.1	4.1
	100	0.1	0.2	0.6	1.1	2.1
	200	0.1	0.2	0.5	0.7	1.2

### For transfer load of 1.5 kg

Positioning distance (mm)		Positioning time (sec)				
		1	10	50	100	200
Speed (mm/s)	50	0.1	0.3	1.1	2.1	4.1
	100	0.1	0.2	0.6	1.1	2.1
	200	0.1	0.1	0.3	0.6	1.1

Refer to page 960 for acceleration time.

- LJ1
- LG1
- LTF
- LC1
- LC7
- LC8
- LXF
- LXP
- LXS
- LC6
- LZ
- LC3F2
- X
- D-
- E-MY

# Guide Rod Type 5 Phase Stepper Motor Without Motor Brake Series LXP

Ball  
Bushing

Ball Screw  
∅8 mm/2 mm lead

## How to Order

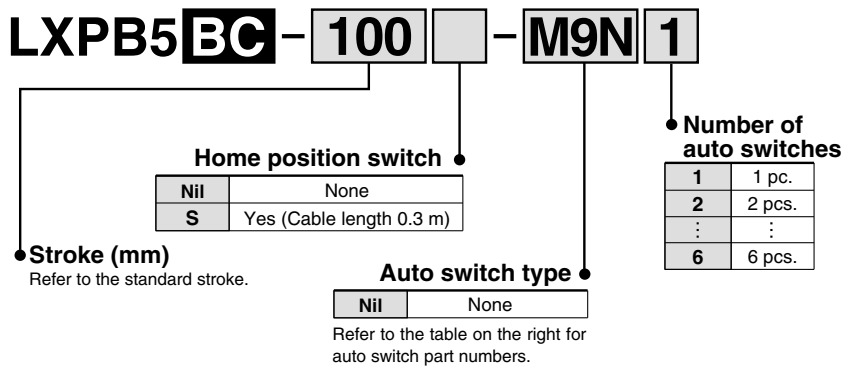

## Auto switch types

Symbol	Model	Wiring/Output type	Lead wire length (m)	Contact
Nil	Without auto switch			
M9N	D-M9N	3 wire/NPN	0.5	N.O. (A contact)
M9P	D-M9P	3 wire/PNP	0.5	N.O. (A contact)
M9B	D-M9B	2 wire	0.5	N.O. (A contact)
F9G	D-F9G	3 wire/NPN	0.5	N.C. (B contact)
F9H	D-F9H	3 wire/PNP	0.5	N.C. (B contact)
F9GL	D-F9GL	3 wire/NPN	3	N.C. (B contact)
F9HL	D-F9HL	3 wire/PNP	3	N.C. (B contact)
M9NL	D-M9NL	3 wire/NPN	3	N.O. (A contact)
M9PL	D-M9PL	3 wire/PNP	3	N.O. (A contact)
M9BL	D-M9BL	2 wire	3	N.O. (A contact)

## Specifications

Standard stroke (mm)		50	75	100	125	150	175	200
Performance	Body mass (kg)	2.0	2.2	2.3	2.6	2.8	2.9	3.1
	Operating temperature range (°C)	5 to 40 (No condensation)						
	Work load (kg)	6 horizontal/5 vertical <sup>Note 1)</sup>						
	Speed (mm/s)	to 30 <sup>Note 2)</sup>						
	Positioning repeatability (mm)	±0.03						
Main parts	Motor	5 phase stepper motor (without brake)						
	Lead screw	Ball screw ∅8 mm, 2 mm lead						
	Guide	Ball bushing						
Home position switch	Model	Photo micro sensor EE-SX673 (Refer to page 1084 for details.)						
Driver	Model	LC6D-507AD-□ (Refer to page 963 details.)						



## Made to order specifications (For details, refer to page 999)

Symbol	Specifications
X20	AC servomotor specification
X60	Low particle generation specification

Note 1) Based on the operating conditions, establish a separate guide when exceeding the maximum allowable lateral load.

Note 2) Since vibration may increase with low speed operation, set the driver to be driven in half-step mode, and use 2 mm/s or more as a guide for speed.

## Operating Conditions

### Allowable lateral load (F)

Stroke	Load (N)
50	42
75	42
100	40
125	42
150	32
175	24
200	17

### Allowable plate rotation torque (T)

Stroke	Torque (N·m)
50	2.87
75	2.47
100	2.17
125	2.38
150	2.16
175	1.98
200	1.82

### Plate non-rotating accuracy (θ)

Non-rotating accuracy
±0.09°

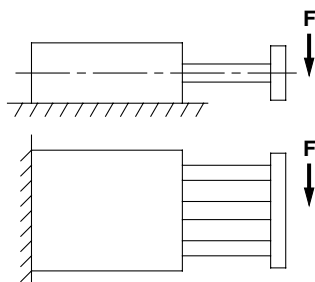
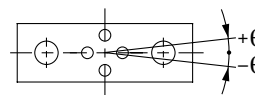

Refer to page 962 for deflection data.



## Dimensions/LXPB5BC

\* The dimension inside [ ] shows the location at which the home position switch operates.

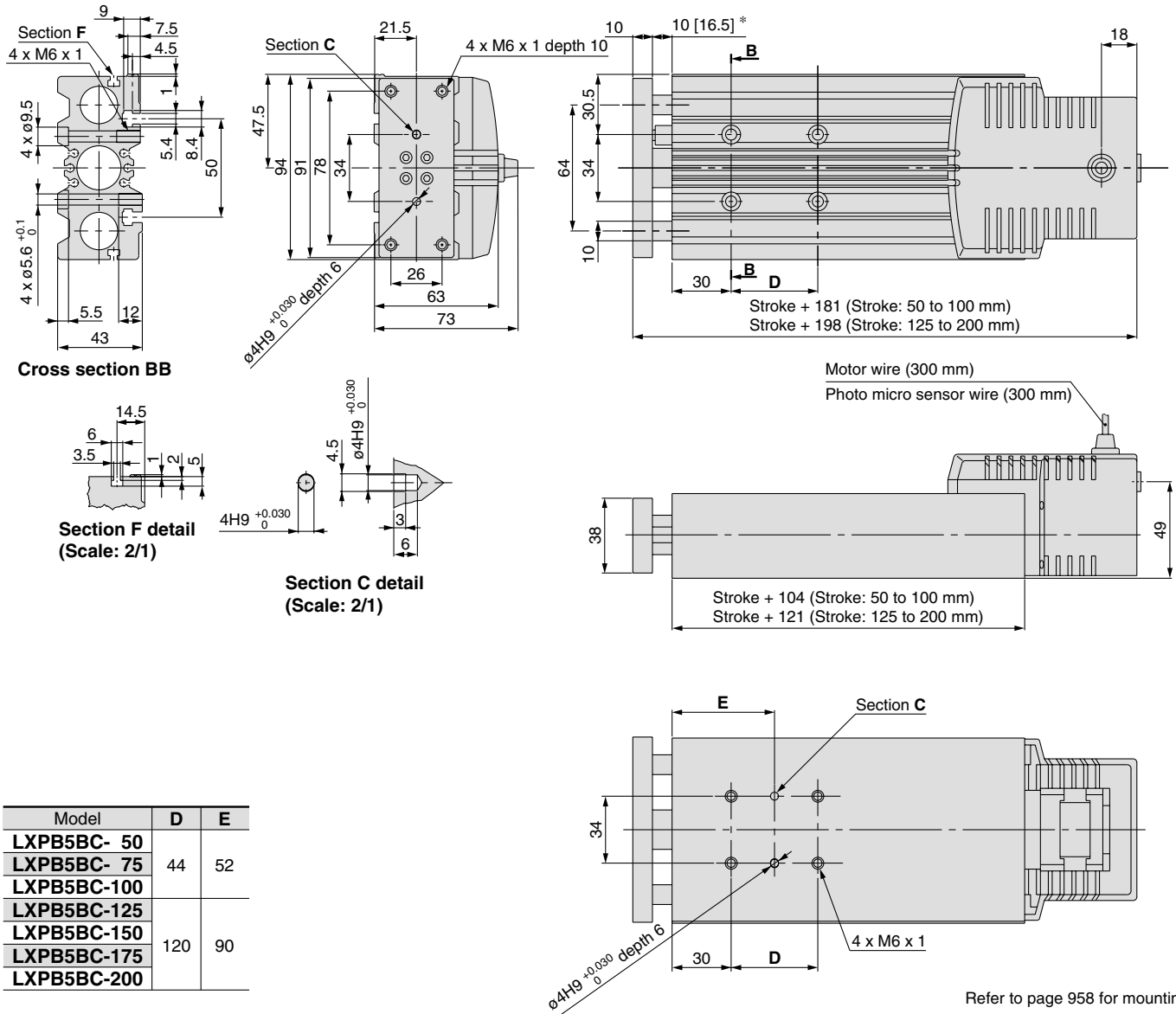

- LJ1
- LG1
- LTF
- LC1
- LC7
- LC8
- LXF
- LXP**
- LXS
- LC6□
- LZ□
- LC3F2
- X□
- D-□
- E-MY

## Positioning Time Guide (for Horizontal Mount)

For transfer load of 0 kg

		Positioning time (sec)				
		1	10	50	100	200
Speed (mm/s)	10	0.2	1.1	5.1	10.1	20.1
	20	0.1	0.6	2.6	5.1	10.1
	30	0.1	0.4	1.7	3.4	6.7

For transfer load of 6 kg

		Positioning time (sec)				
		1	10	50	100	200
Speed (mm/s)	10	0.2	1.1	5.1	10.1	20.1
	20	0.1	0.6	2.6	5.1	10.1
	30	0.1	0.4	1.7	3.4	6.7

For transfer load of 3 kg

		Positioning time (sec)				
		1	10	50	100	200
Speed (mm/s)	10	0.2	1.1	5.1	10.1	20.1
	20	0.1	0.6	2.6	5.1	10.1
	30	0.1	0.4	1.7	3.4	6.7

Refer to page 961 for acceleration time.

# Guide Rod Type 5 Phase Stepper Motor Without Motor Brake Series LXP

Ball  
Bushing

Ball Screw  
ø8 mm/5 mm lead

## How to Order

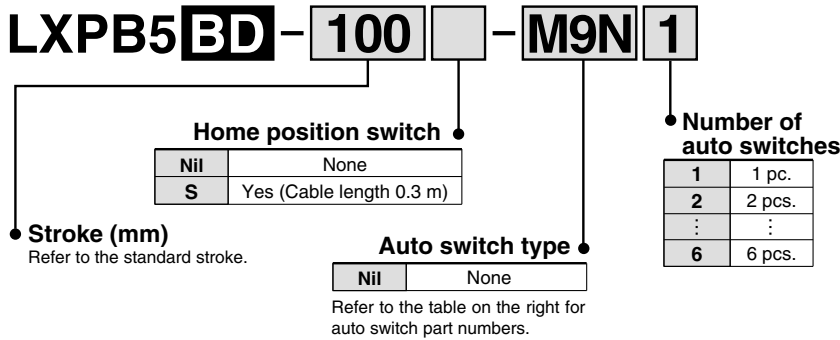

## Auto switch types

Symbol	Model	Wiring/Output type	Lead wire length (m)	Contact
Nil	Without auto switch			
M9N	D-M9N	3 wire/NPN	0.5	N.O. (A contact)
M9P	D-M9P	3 wire/PNP	0.5	N.O. (A contact)
M9B	D-M9B	2 wire	0.5	N.O. (A contact)
F9G	D-F9G	3 wire/NPN	0.5	N.C. (B contact)
F9H	D-F9H	3 wire/PNP	0.5	N.C. (B contact)
F9GL	D-F9GL	3 wire/NPN	3	N.C. (B contact)
F9HL	D-F9HL	3 wire/PNP	3	N.C. (B contact)
M9NL	D-M9NL	3 wire/NPN	3	N.O. (A contact)
M9PL	D-M9PL	3 wire/PNP	3	N.O. (A contact)
M9BL	D-M9BL	2 wire	3	N.O. (A contact)

## Specifications

Standard stroke (mm)		50	75	100	125	150	175	200
Performance	Body mass (kg)	2.0	2.2	2.3	2.6	2.8	2.9	3.1
	Operating temperature range (°C)	5 to 40 (No condensation)						
	Work load (kg)	6 horizontal/5 vertical <sup>Note 1)</sup>						
	Speed (mm/s)	to 80 <sup>Note 2)</sup>						
	Positioning repeatability (mm)	±0.03						
Main parts	Motor	5 phase stepper motor (without brake)						
	Lead screw	Ball screw ø8 mm, 5 mm lead						
	Guide	Ball bushing						
Home position switch	Model	Photo micro sensor EE-SX673 (Refer to page 1084 for details.)						
Driver	Model	LC6D-507AD-□ (Refer to page 963 for details.)						



**Made to order specifications**  
(For details, refer to page 999)

Symbol	Specifications
X20	AC servomotor specification
X60	Low particle generation specification

Note 1) Based on the operating conditions, establish a separate guide when exceeding the maximum allowable lateral load.

Note 2) Since vibration may increase with low speed operation, set the driver to be driven in half-step mode, and use 5 mm/s or more as a guide for speed.

## Operating Conditions

### Allowable lateral load (F)

Stroke	Load (N)
50	42
75	42
100	40
125	42
150	32
175	24
200	17

### Allowable plate rotation torque (T)

Stroke	Torque (N·m)
50	2.87
75	2.47
100	2.17
125	2.38
150	2.16
175	1.98
200	1.82

### Plate non-rotating accuracy (θ)

Non-rotating accuracy
±0.09°

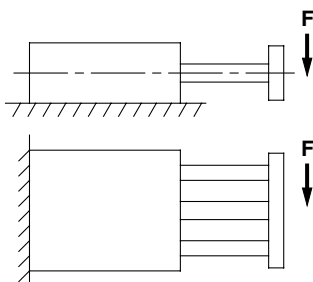
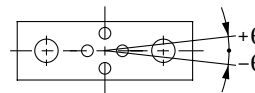

Refer to page 962 for deflection data.

**Dimensions/LXPB5BD**

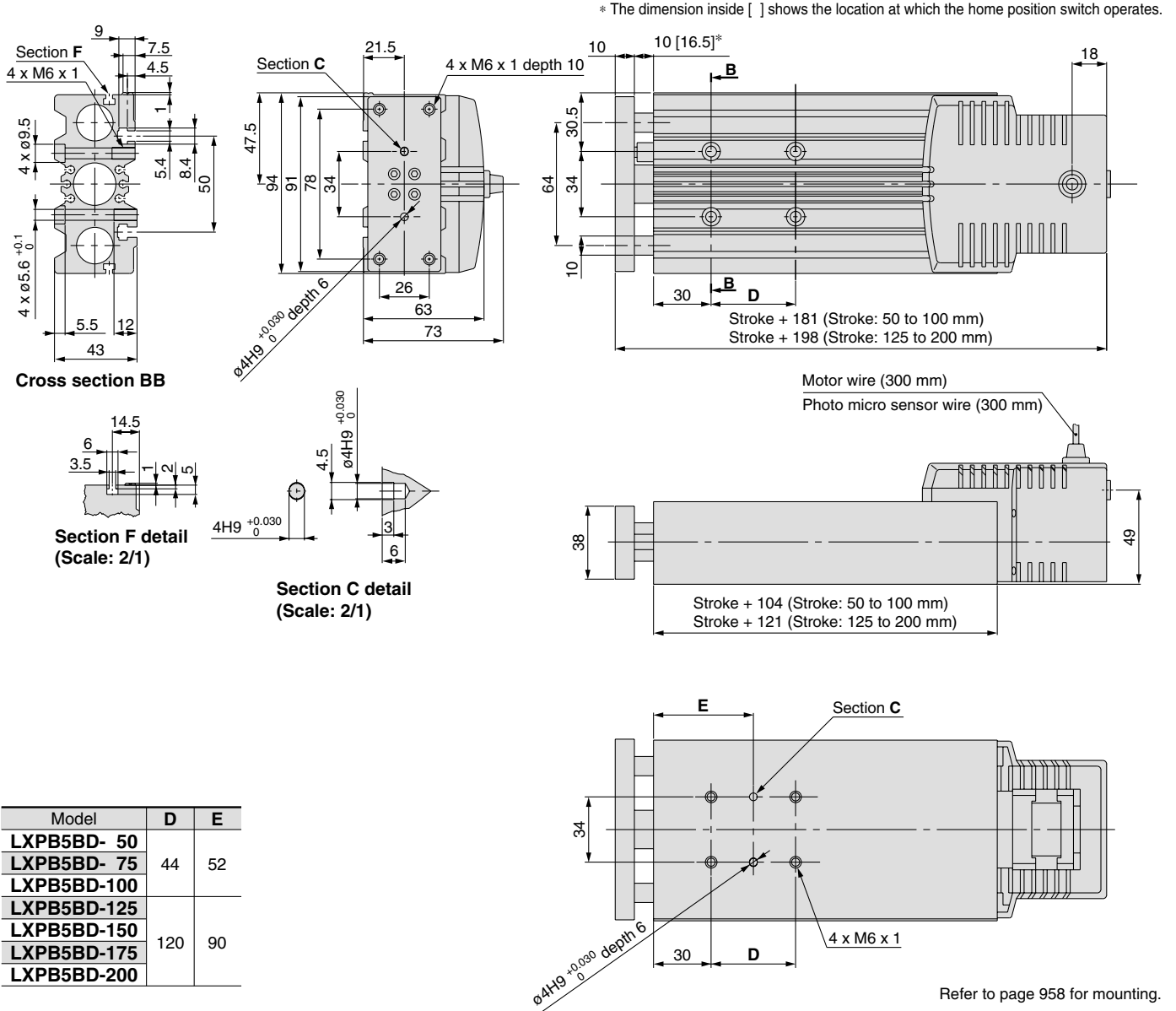

- LJ1
- LG1
- LTF
- LC1
- LC7
- LC8
- LXF
- LXP**
- LXS
- LC6□
- LZ□
- LC3F2
- X□
- D-□
- E-MY

**Positioning Time Guide (for Horizontal Mount)**

**For transfer load of 0 kg**

		Positioning time (sec)				
		1	10	50	100	200
Speed (mm/s)	10	0.2	1.1	5.1	10.1	20.1
	40	0.1	0.3	1.3	2.6	5.1
	80	0.1	0.2	0.7	1.3	2.6

**For transfer load of 6 kg**

		Positioning time (sec)				
		1	10	50	100	200
Speed (mm/s)	10	0.2	1.1	5.1	10.1	20.1
	40	0.1	0.3	1.3	2.6	5.1
	80	0.1	0.2	0.7	1.3	2.6

**For transfer load of 3 kg**

		Positioning time (sec)				
		1	10	50	100	200
Speed (mm/s)	10	0.2	1.1	5.1	10.1	20.1
	40	0.1	0.3	1.3	2.6	5.1
	80	0.1	0.2	0.7	1.3	2.6

Refer to page 961 for acceleration time.

# Guide Rod Type 5 Phase Stepper Motor Without Motor Brake Series LXP

Ball  
Bushing

Slide Screw  
∅8 mm/6 mm lead

## How to Order

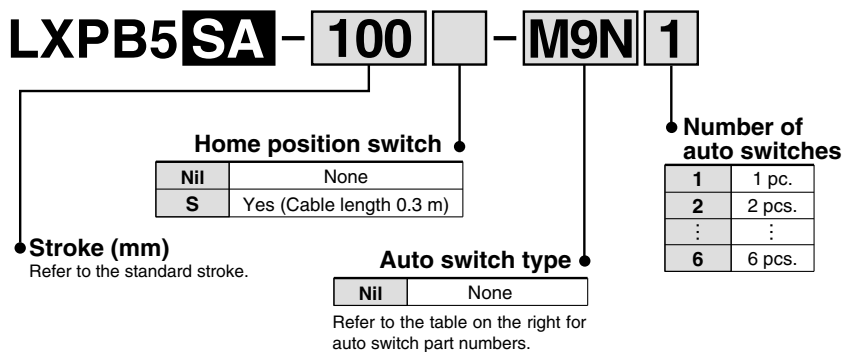

### Auto switch types

Symbol	Model	Wiring/Output type	Lead wire length (m)	Contact
Nil	Without auto switch			
M9N	D-M9N	3 wire/NPN	0.5	N.O. (A contact)
M9P	D-M9P	3 wire/PNP	0.5	N.O. (A contact)
M9B	D-M9B	2 wire	0.5	N.O. (A contact)
F9G	D-F9G	3 wire/NPN	0.5	N.C. (B contact)
F9H	D-F9H	3 wire/PNP	0.5	N.C. (B contact)
F9GL	D-F9GL	3 wire/NPN	3	N.C. (B contact)
F9HL	D-F9HL	3 wire/PNP	3	N.C. (B contact)
M9NL	D-M9NL	3 wire/NPN	3	N.O. (A contact)
M9PL	D-M9PL	3 wire/PNP	3	N.O. (A contact)
M9BL	D-M9BL	2 wire	3	N.O. (A contact)

## Specifications

Standard stroke (mm)		50	75	100	125	150	175	200
Performance	Body mass (kg)	2.0	2.2	2.3	2.6	2.8	2.9	3.1
	Operating temperature range (°C)	5 to 40 (No condensation)						
	Work load (kg)	4 horizontal/4 vertical <sup>Note 1)</sup>						
	Speed (mm/s)	to 100 <sup>Note 2)</sup>						
	Positioning repeatability (mm)	±0.05						
Main parts	Motor	5 phase stepper motor (without brake)						
	Lead screw	Slide screw ∅8 mm, 6 mm lead						
	Guide	Ball bushing						
Home position switch	Model	Photo micro sensor EE-SX673 (Refer to page 1084 for details.)						
Driver	Model	LC6D-507AD-□ (Refer to page 963 for details.)						

Note 1) Based on the operating conditions, establish a separate guide when exceeding the maximum allowable lateral load.

Note 2) Since vibration may increase with low speed operation, set the driver to be driven in half-step mode, and use 6 mm/s or more as a guide for speed.

## Operating Conditions

### Allowable lateral load (F)

Stroke	Load (N)
50	42
75	42
100	40
125	42
150	32
175	24
200	17

### Allowable plate rotation torque (T)

Stroke	Torque (N·m)
50	2.87
75	2.47
100	2.17
125	2.38
150	2.16
175	1.98
200	1.82

### Plate non-rotating accuracy (θ)

Non-rotating accuracy
±0.09°

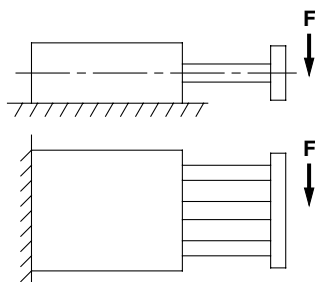
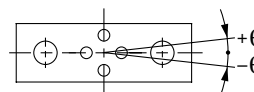

Refer to page 962 for deflection data.

**Dimensions/LXPB5SA**

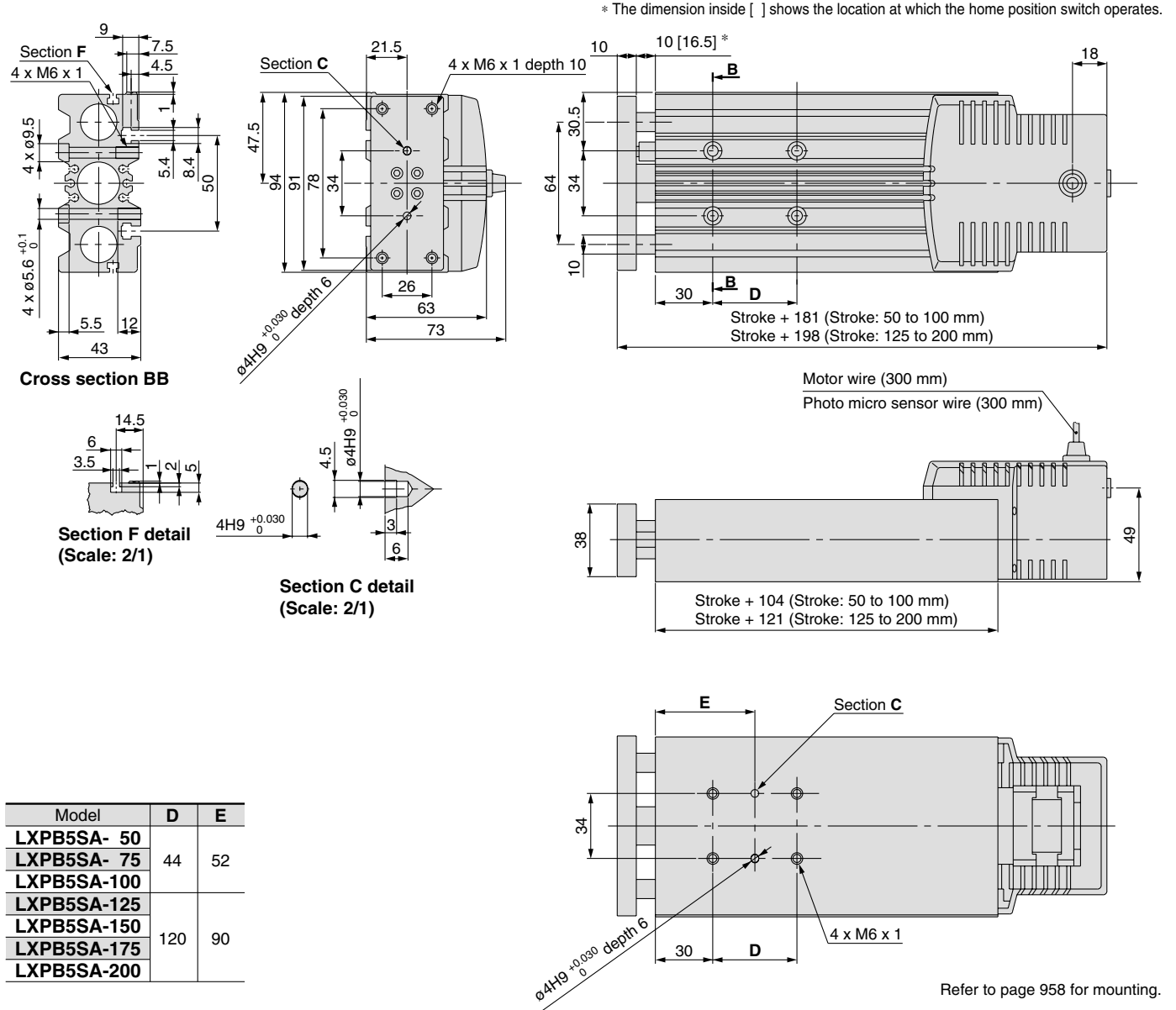

- LJ1
- LG1
- LTF
- LC1
- LC7
- LC8
- LXF
- LXP**
- LXS
- LC6
- LZ
- LC3F2
- X
- D-
- E-MY

**Positioning Time Guide (for Horizontal Mount)**

For transfer load of 0 kg

		Positioning time (sec)				
		1	10	50	100	200
Speed (mm/s)	10	0.2	1.1	5.1	10.1	20.1
	50	0.1	0.3	1.1	2.1	4.1
	100	0.1	0.2	0.6	1.1	2.1

For transfer load of 4 kg

		Positioning time (sec)				
		1	10	50	100	200
Speed (mm/s)	10	0.2	1.1	5.1	10.1	20.1
	50	0.1	0.3	1.1	2.1	4.1
	100	0.1	0.2	0.6	1.1	2.1

For transfer load of 2 kg

		Positioning time (sec)				
		1	10	50	100	200
Speed (mm/s)	10	0.2	1.1	5.1	10.1	20.1
	50	0.1	0.3	1.1	2.1	4.1
	100	0.1	0.2	0.6	1.1	2.1

Refer to page 960 for acceleration time.

# Guide Rod Type 5 Phase Stepper Motor Without Motor Brake Series LXP

Ball  
Bushing

Slide Screw  
ø8 mm/12 mm lead

## How to Order

LXPB5 **SB** - **100** - **M9N** **1**

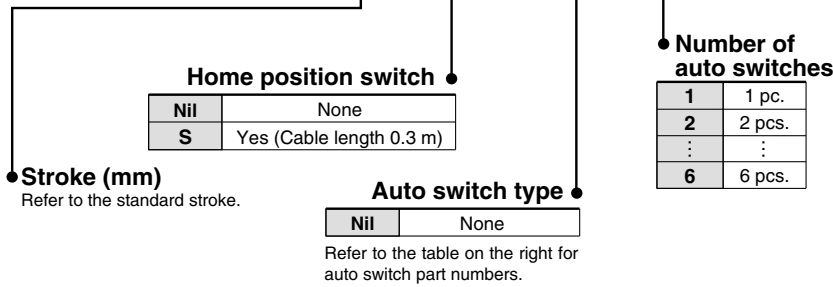

### Auto switch types

Symbol	Model	Wiring/Output type	Lead wire length (m)	Contact
Nil	Without auto switch			
M9N	D-M9N	3 wire/NPN	0.5	N.O. (A contact)
M9P	D-M9P	3 wire/PNP	0.5	N.O. (A contact)
M9B	D-M9B	2 wire	0.5	N.O. (A contact)
F9G	D-F9G	3 wire/NPN	0.5	N.C. (B contact)
F9H	D-F9H	3 wire/PNP	0.5	N.C. (B contact)
F9GL	D-F9GL	3 wire/NPN	3	N.C. (B contact)
F9HL	D-F9HL	3 wire/PNP	3	N.C. (B contact)
M9NL	D-M9NL	3 wire/NPN	3	N.O. (A contact)
M9PL	D-M9PL	3 wire/PNP	3	N.O. (A contact)
M9BL	D-M9BL	2 wire	3	N.O. (A contact)

## Specifications

Standard stroke (mm)		50	75	100	125	150	175	200
Performance	Body mass (kg)	2.0	2.2	2.3	2.6	2.8	2.9	3.1
	Operating temperature range (°C)	5 to 40 (No condensation)						
	Work load (kg)	2 horizontal/2 vertical <sup>Note 1)</sup>						
	Speed (mm/s)	to 200 <sup>Note 2)</sup>						
	Positioning repeatability (mm)	±0.05						
Main parts	Motor	5 phase stepper motor (without brake)						
	Lead screw	Slide screw ø8 mm, 12 mm lead						
	Guide	Ball bushing						
Home position switch	Model	Photo micro sensor EE-SX673 (Refer to page 1084 for details.)						
Driver	Model	LC6D-507AD-□ (Refer to page 963 for details.)						

Note 1) Based on the operating conditions, establish a separate guide when exceeding the maximum allowable lateral load.

Note 2) Since vibration may increase with low speed operation, set the driver to be driven in half-step mode, and use 12 mm/s or more as a guide for speed.

## Operating Conditions

### Allowable lateral load (F)

Stroke	Load (N)
50	42
75	42
100	40
125	42
150	32
175	24
200	17

### Allowable plate rotation torque (T)

Stroke	Torque (N·m)
50	2.87
75	2.47
100	2.17
125	2.38
150	2.16
175	1.98
200	1.82

### Plate non-rotating accuracy (θ)

Non-rotating accuracy
±0.09°

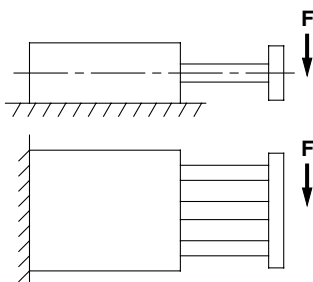
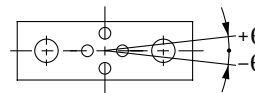

Refer to page 962 for deflection data.



**Dimensions/LXPB5SB**

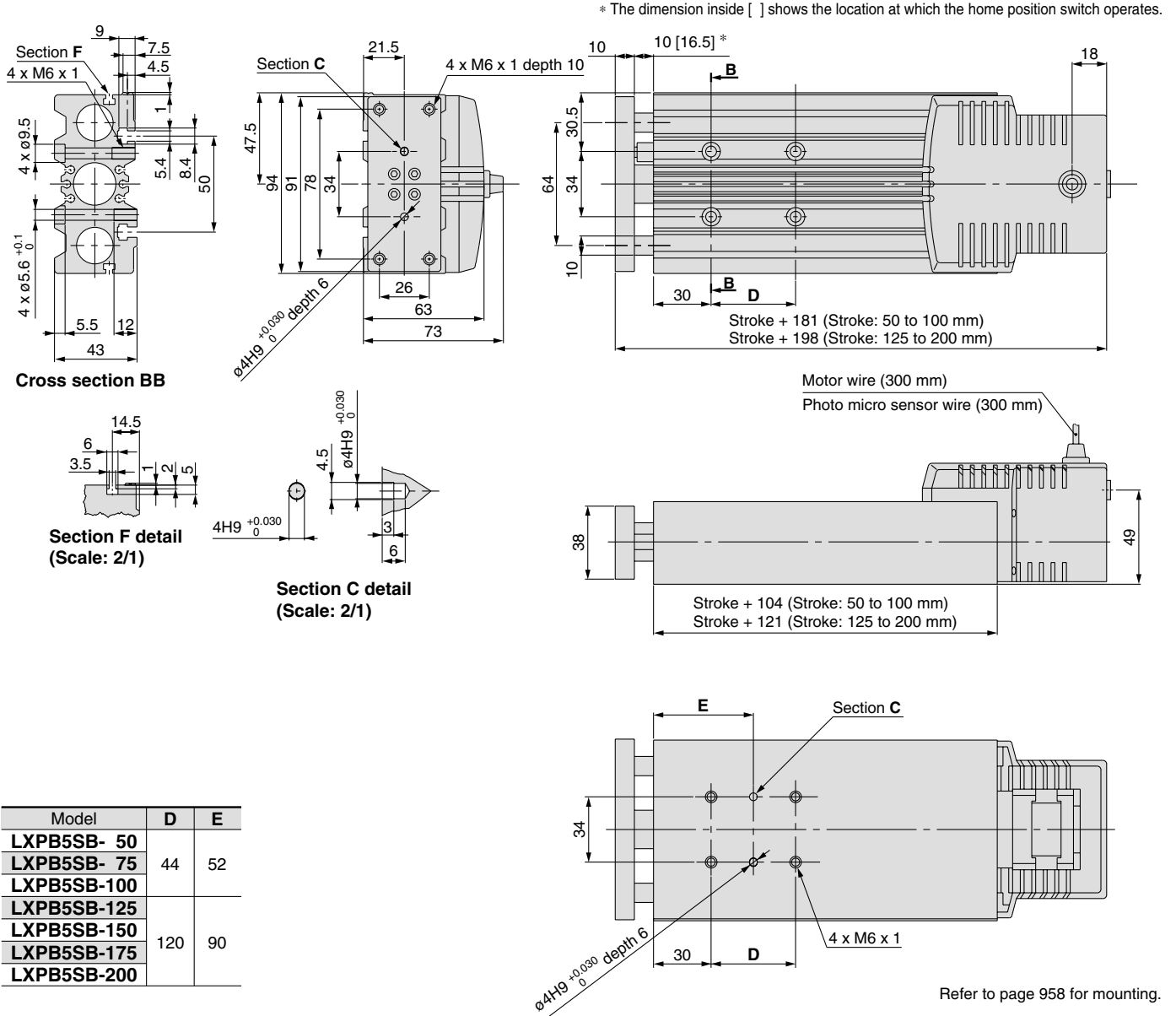

Model	D	E
LXPB5SB- 50	44	52
LXPB5SB- 75		
LXPB5SB-100		
LXPB5SB-125	120	90
LXPB5SB-150		
LXPB5SB-175		
LXPB5SB-200		

**Positioning Time Guide (for Horizontal Mount)**

For transfer load of 0 kg

		Positioning time (sec)				
		1	10	50	100	200
Speed (mm/s)	50	0.1	0.3	1.1	2.1	4.1
	100	0.1	0.2	0.6	1.1	2.1
	200	0.1	0.1	0.3	0.6	1.1

For transfer load of 2 kg

		Positioning time (sec)				
		1	10	50	100	200
Speed (mm/s)	50	0.1	0.3	1.1	2.1	4.1
	100	0.1	0.2	0.6	1.1	2.1
	200	0.1	0.1	0.3	0.6	1.1

For transfer load of 1 kg

		Positioning time (sec)				
		1	10	50	100	200
Speed (mm/s)	50	0.1	0.3	1.1	2.1	4.1
	100	0.1	0.2	0.6	1.1	2.1
	200	0.1	0.1	0.3	0.6	1.1

Refer to page 960 for acceleration time.

- LJ1
- LG1
- LTF
- LC1
- LC7
- LC8
- LXF
- LXP**
- LXS
- LC6
- LZ
- LC3F2
- X
- D-
- E-MY

# Guide Rod Type 5 Phase Stepper Motor With Motor Brake Series LXP

Ball Bushing

Ball Screw  
∅ 8 mm / 2 mm lead

## How to Order

**LXPB5 BC - 100 B - M9N 1**

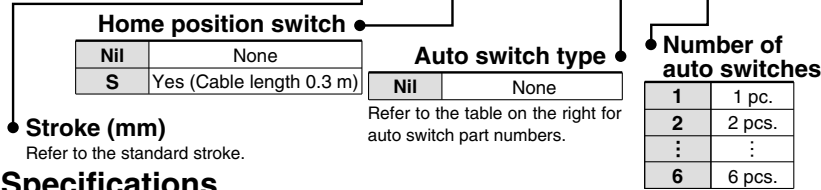

## Specifications

Standard stroke (mm)		50	75	100	125	150	175	200	
Performance	Body mass (kg)	2.2	2.4	2.5	2.8	3.0	3.1	3.3	
	Operating temperature range (°C)	5 to 40 (No condensation)							
	Work load (kg)	6 horizontal/5 vertical <sup>Note 1)</sup>							
	Speed (mm/s)	to 30 <sup>Note 2)</sup>							
	Positioning repeatability (mm)	±0.03							
Main parts	Motor	5 phase stepper motor (with brake)							
	Lead screw	Ball screw ∅8 mm, 2 mm lead							
	Guide	Ball bushing							
	Electromagnetic brake	Model	De-energized operating type						
		Static torque (N·m)	0.1 or more						
Rated voltage (V)		24 DC ±5%							
Power consumption (W)	5								
Home position switch	Model	Photo micro sensor EE-SX673 (Refer to page 1084 for details.)							
Driver	Model	LC6D-507AD-□ (Refer to page 963 for details.)							

## Auto switch types

Symbol	Model	Wiring/Output type	Lead wire length (m)	Contact
Nil	Without auto switch			
M9N	D-M9N	3 wire/NPN	0.5	N.O. (A contact)
M9P	D-M9P	3 wire/PNP	0.5	N.O. (A contact)
M9B	D-M9B	2 wire	0.5	N.O. (A contact)
F9G	D-F9G	3 wire/NPN	0.5	N.C. (B contact)
F9H	D-F9H	3 wire/PNP	0.5	N.C. (B contact)
F9GL	D-F9GL	3 wire/NPN	3	N.C. (B contact)
F9HL	D-F9HL	3 wire/PNP	3	N.C. (B contact)
M9NL	D-M9NL	3 wire/NPN	3	N.O. (A contact)
M9PL	D-M9PL	3 wire/PNP	3	N.O. (A contact)
M9BL	D-M9BL	2 wire	3	N.O. (A contact)



**Made to order specifications**  
(For details, refer to page 999)

Symbol	Specifications
X20	AC servomotor specification
X60	Low particle generation specification

Note 1) Based on the operating conditions, establish a separate guide when exceeding the maximum allowable lateral load.

Note 2) Since vibration may increase with low speed operation, set the driver to be driven in half-step mode, and use 2 mm/s or more as a guide for speed.

## Lifter Operation Range

This is the operating range for ball bushings. Use within the allowable thrust range.

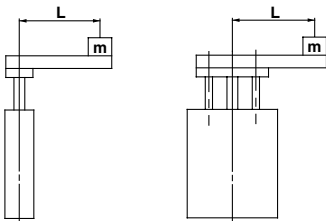

### 50 to 200 mm stroke

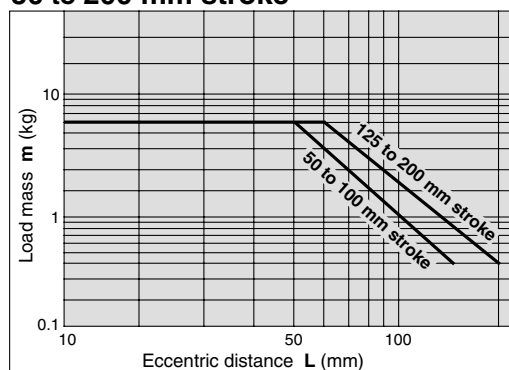

## Operating Conditions

### Allowable lateral load (F)

Stroke	Load (N)
50	42
75	42
100	40
125	42
150	32
175	24
200	17

### Allowable plate rotation torque (T)

Stroke	Torque (N·m)
50	2.87
75	2.47
100	2.17
125	2.38
150	2.16
175	1.98
200	1.82

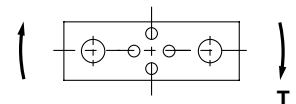
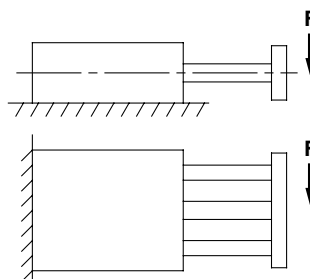

### Plate non-rotating accuracy ( $\theta$ )

Non-rotating accuracy  
±0.09°

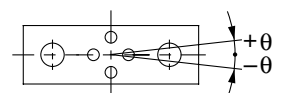

Refer to page 962 for deflection data.

## Dimensions/LXPB5BC

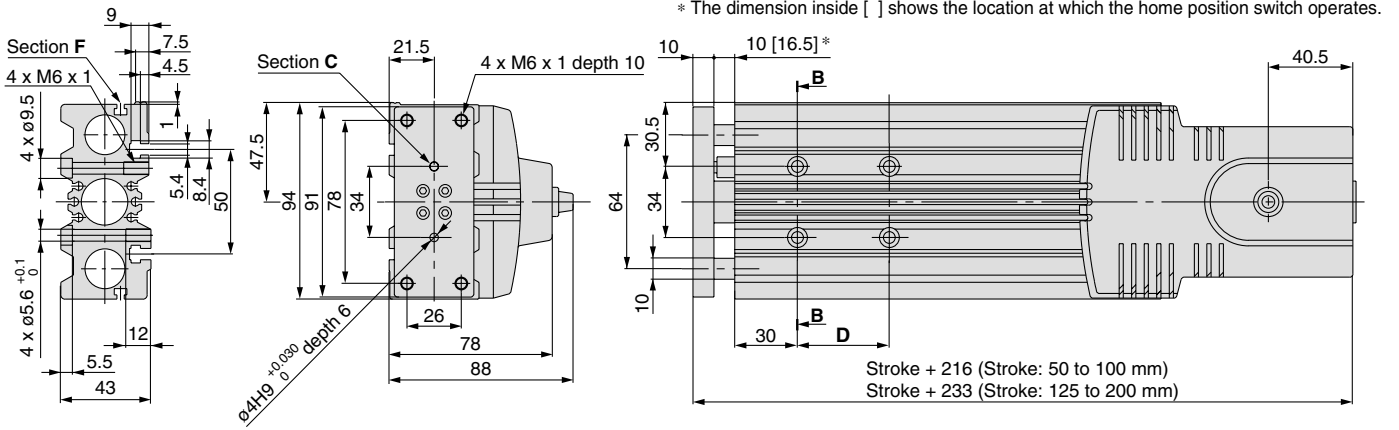

Cross section BB

### Brake electrical circuit

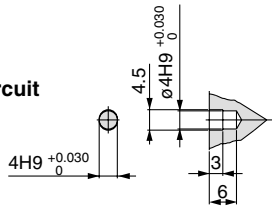
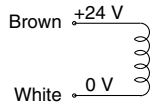

Section C detail  
(Scale: 2/1)

Motor wire (300 mm)  
Brake wire (300 mm)  
Photo micro sensor wire (300 mm)

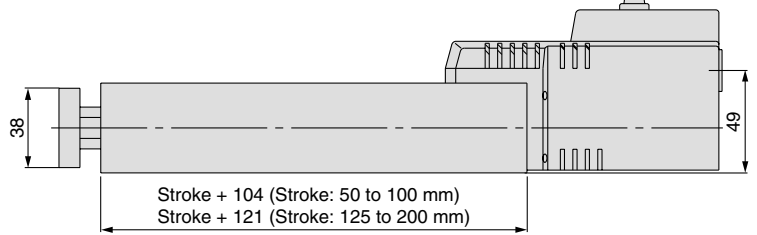

Note) A contact protection circuit is required when connecting a brake.

Model	D	E
LXPB5BC- 50□B	44	52
LXPB5BC- 75□B		
LXPB5BC-100□B		
LXPB5BC-125□B		
LXPB5BC-150□B	120	90
LXPB5BC-175□B		
LXPB5BC-200□B		

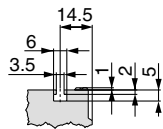

Section F detail  
(Scale: 2/1)

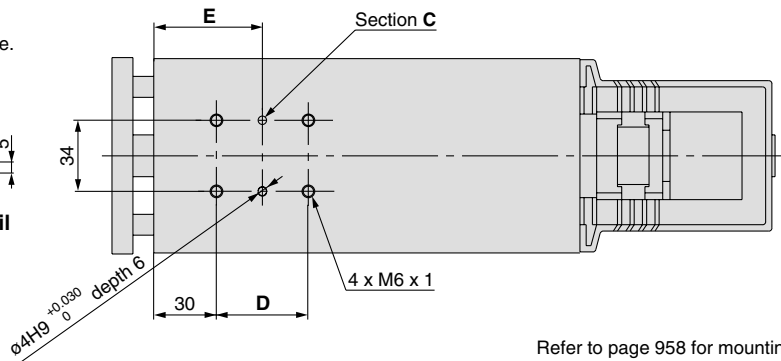

Refer to page 958 for mounting.

## Positioning Time Guide (for Vertical Mount)

### For transfer load of 0 kg

Positioning distance (mm)		Positioning time (sec)				
		1	10	50	100	200
Speed (mm/s)	10	0.2	1.1	5.1	10.1	20.1
	20	0.1	0.6	2.6	5.1	10.1
	30	0.1	0.4	1.7	3.4	6.7

### For transfer load of 5 kg

Positioning distance (mm)		Positioning time (sec)				
		1	10	50	100	200
Speed (mm/s)	10	0.2	1.1	5.1	10.1	20.1
	20	0.1	0.6	2.6	5.1	10.1
	30	0.1	0.4	1.7	3.4	6.7

### For transfer load of 2.5 kg

Positioning distance (mm)		Positioning time (sec)				
		1	10	50	100	200
Speed (mm/s)	10	0.2	1.1	5.1	10.1	20.1
	20	0.1	0.6	2.6	5.1	10.1
	30	0.1	0.4	1.7	3.4	6.7

Refer to page 961 for acceleration time.

- LJ1
- LG1
- LTF
- LC1
- LC7
- LC8
- LXF
- LXP
- LXS
- LC6□
- LZ□
- LC3F2
- X□
- D-□
- E-MY

# Guide Rod Type 5 Phase Stepper Motor With Motor Brake Series LXP

Ball Bushing

Ball Screw  
∅ 8 mm/5 mm lead

## How to Order

LXPB5 **BD** - **100** **B** - **M9N** **1**

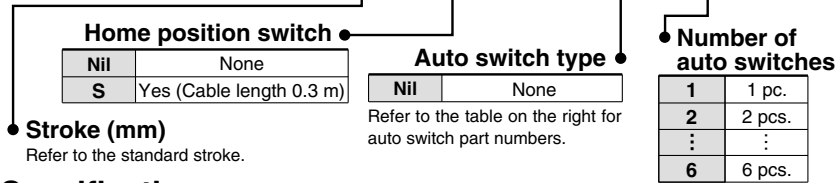

## Specifications

Standard stroke (mm)		50	75	100	125	150	175	200	
Performance	Body mass (kg)	2.2	2.4	2.5	2.8	3.0	3.1	3.3	
	Operating temperature range (°C)	5 to 40 (No condensation)							
	Work load (kg)	6 horizontal/5 vertical <sup>Note 1)</sup>							
	Speed (mm/s)	to 80 <sup>Note 2)</sup>							
	Positioning repeatability (mm)	±0.03							
Main parts	Motor	5 phase stepper motor (with brake)							
	Lead screw	Ball screw ∅8 mm, 5 mm lead							
	Guide	Ball bushing							
	Electromagnetic brake	Model	De-energized operating type						
		Static torque (N·m)	0.1 or more						
Rated voltage (V)		24 DC ±5%							
	Power consumption (W)	5							
Home position switch	Model	Photo micro sensor EE-SX673 (Refer to page 1084 for details.)							
Driver	Model	LC6D-507AD-□ (Refer to page 963 for details.)							

## Auto switch types

Symbol	Model	Wiring/Output type	Lead wire length (m)	Contact
Nil	Without auto switch			
M9N	D-M9N	3 wire/NPN	0.5	N.O. (A contact)
M9P	D-M9P	3 wire/PNP	0.5	N.O. (A contact)
M9B	D-M9B	2 wire	0.5	N.O. (A contact)
F9G	D-F9G	3 wire/NPN	0.5	N.C. (B contact)
F9H	D-F9H	3 wire/PNP	0.5	N.C. (B contact)
F9GL	D-F9GL	3 wire/NPN	3	N.C. (B contact)
F9HL	D-F9HL	3 wire/PNP	3	N.C. (B contact)
M9NL	D-M9NL	3 wire/NPN	3	N.O. (A contact)
M9PL	D-M9PL	3 wire/PNP	3	N.O. (A contact)
M9BL	D-M9BL	2 wire	3	N.O. (A contact)



## Made to order specifications (For details, refer to page 999)

Symbol	Specifications
X20	AC servomotor specification
X60	Low particle generation specification

Note 1) Based on the operating conditions, establish a separate guide when exceeding the maximum allowable lateral load.

Note 2) Since vibration may increase with low speed operation, set the driver to be driven in half-step mode, and use 5 mm/s or more as a guide for speed.

## Lifter Operation Range

This is the operating range for ball bushings. Use within the allowable thrust range.

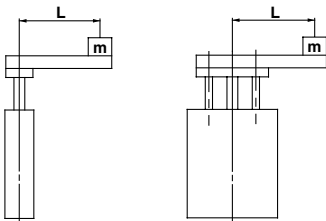

### 50 to 200 mm stroke

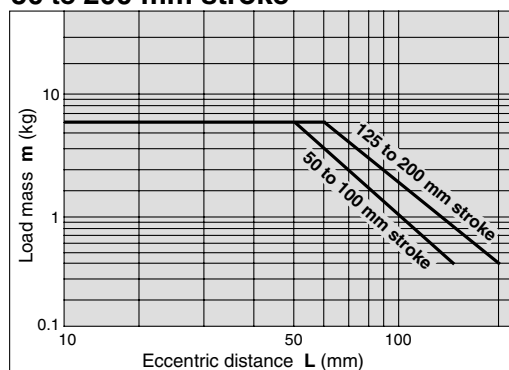

## Operating Conditions

### Allowable lateral load (F)

Stroke	Load (N)
50	42
75	42
100	40
125	42
150	32
175	24
200	17

### Allowable plate rotation torque (T)

Stroke	Torque (N·m)
50	2.87
75	2.47
100	2.17
125	2.38
150	2.16
175	1.98
200	1.82

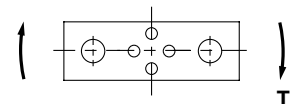
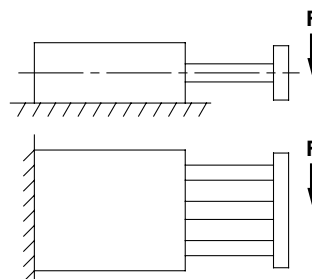

### Plate non-rotating accuracy ( $\theta$ )

Non-rotating accuracy  
±0.09°

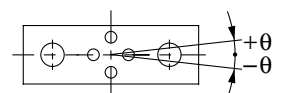

Refer to page 962 for deflection data.

## Dimensions/LXPB5BD

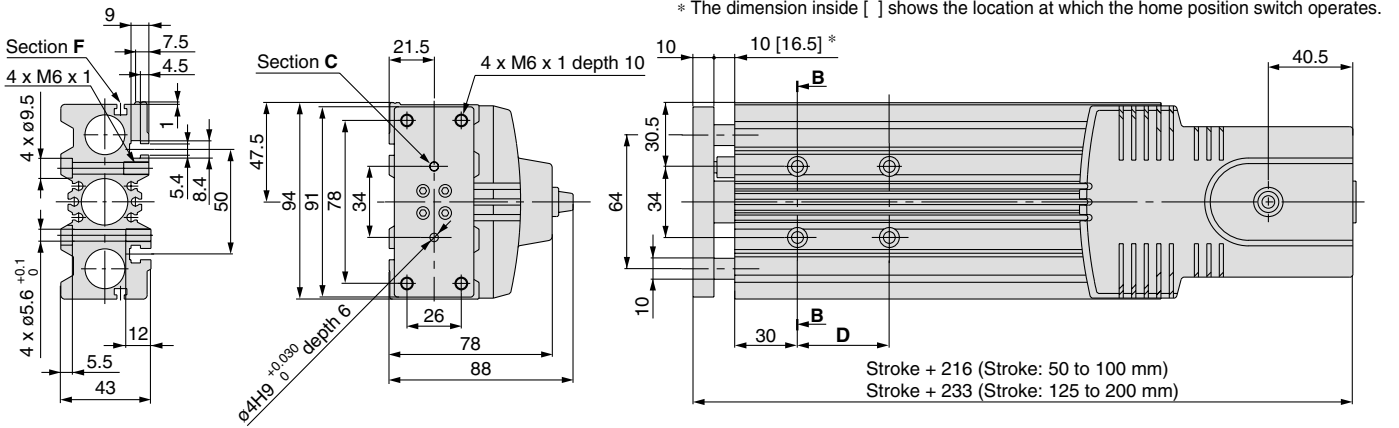

Cross section BB

### Brake electrical circuit

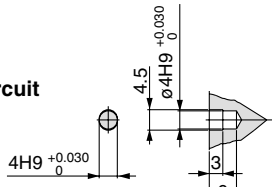
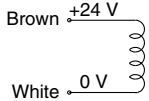

Section C detail  
(Scale: 2/1)

Motor wire (300 mm)  
Brake wire (300 mm)  
Photo micro sensor wire (300 mm)

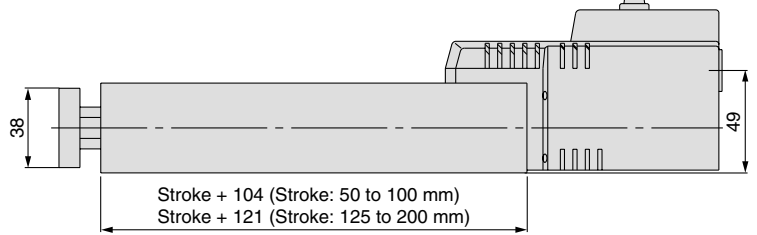

Note) A contact protection circuit is required when connecting a brake.

Model	D	E
LXPB5BD- 50□B	44	52
LXPB5BD- 75□B		
LXPB5BD-100□B		
LXPB5BD-125□B		
LXPB5BD-150□B	120	90
LXPB5BD-175□B		
LXPB5BD-200□B		

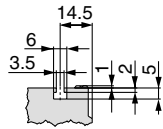

Section F detail  
(Scale: 2/1)

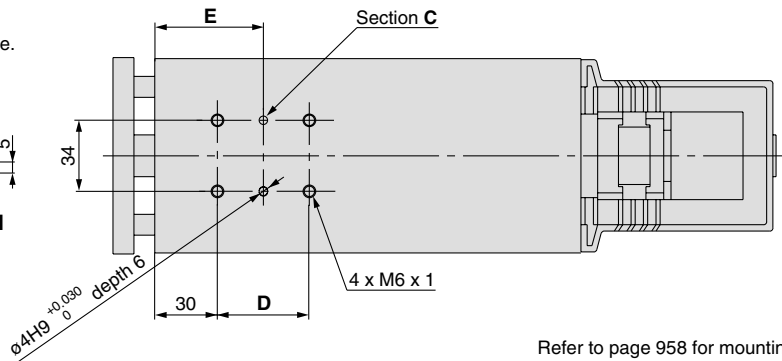

Refer to page 958 for mounting.

## Positioning Time Guide (for Vertical Mount)

### For transfer load of 0 kg

Positioning distance (mm)		Positioning time (sec)				
		1	10	50	100	200
Speed (mm/s)	10	0.2	1.1	5.1	10.1	20.1
	40	0.1	0.3	1.3	2.6	5.1
	80	0.1	0.2	0.7	1.3	2.6

### For transfer load of 5 kg

Positioning distance (mm)		Positioning time (sec)				
		1	10	50	100	200
Speed (mm/s)	10	0.2	1.1	5.1	10.1	20.1
	40	0.1	0.3	1.3	2.6	5.1
	80	0.1	0.2	0.7	1.3	2.6

### For transfer load of 2.5 kg

Positioning distance (mm)		Positioning time (sec)				
		1	10	50	100	200
Speed (mm/s)	10	0.2	1.1	5.1	10.1	20.1
	40	0.1	0.3	1.3	2.6	5.1
	80	0.1	0.2	0.7	1.3	2.6

Refer to page 961 for acceleration time.

# Guide Rod Type 5 Phase Stepper Motor With Motor Brake Series LXP

Ball  
Bushing

Slide Screw  
Ø 8 mm/6 mm lead

## How to Order

LXPB5 SA - 100 B - M9N 1

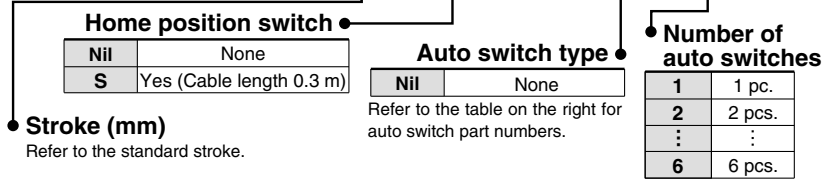

## Auto switch types

Symbol	Model	Wiring/Output type	Lead wire length (m)	Contact
Nil	Without auto switch			
M9N	D-M9N	3 wire/NPN	0.5	N.O. (A contact)
M9P	D-M9P	3 wire/PNP	0.5	N.O. (A contact)
M9B	D-M9B	2 wire	0.5	N.O. (A contact)
F9G	D-F9G	3 wire/NPN	0.5	N.C. (B contact)
F9H	D-F9H	3 wire/PNP	0.5	N.C. (B contact)
F9GL	D-F9GL	3 wire/NPN	3	N.C. (B contact)
F9HL	D-F9HL	3 wire/PNP	3	N.C. (B contact)
M9NL	D-M9NL	3 wire/NPN	3	N.O. (A contact)
M9PL	D-M9PL	3 wire/PNP	3	N.O. (A contact)
M9BL	D-M9BL	2 wire	3	N.O. (A contact)

## Specifications

Standard stroke (mm)		50	75	100	125	150	175	200	
Performance	Body mass (kg)	2.2	2.4	2.5	2.8	3.0	3.1	3.3	
	Operating temperature range (°C)	5 to 40 (No condensation)							
	Work load (kg)	4 horizontal/4 vertical <sup>Note 1)</sup>							
	Speed (mm/s)	to 100 <sup>Note 2)</sup>							
	Positioning repeatability (mm)	±0.05							
Main parts	Motor	5 phase stepper motor (with brake)							
	Lead screw	Slide screw ø8 mm, 6 mm lead							
	Guide	Ball bushing							
	Electromagnetic brake	Model	De-energized operating type						
		Static torque (N-m)	0.1 or more						
Rated voltage (V)		24 DC ±5%							
Home position switch	Power consumption (W)	5							
	Model	Photo micro sensor EE-SX673 (Refer to page 1084 for details.)							
Driver	Model	LC6D-507AD-□ (Refer to page 963 for details.)							

Note 1) Based on the operating conditions, establish a separate guide when exceeding the maximum allowable lateral load.

Note 2) Since vibration may increase with low speed operation, set the driver to be driven in half-step mode, and use 6 mm/s or more as a guide for speed.

## Lifter Operation Range

This is the operating range for ball bushings. Use within the allowable thrust range.

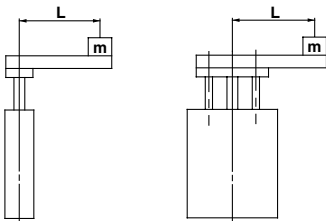

### 50 to 200 mm stroke

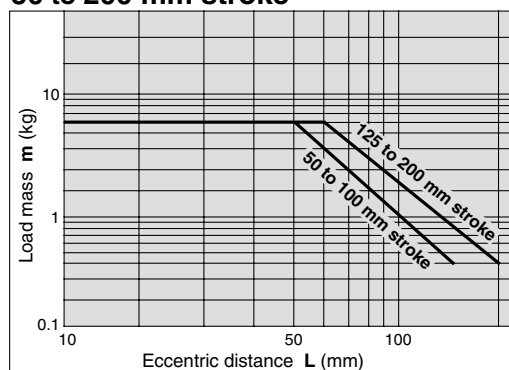

## Operating Conditions

### Allowable lateral load (F)

Stroke	Load (N)
50	42
75	42
100	40
125	42
150	32
175	24
200	17

### Allowable plate rotation torque (T)

Stroke	Torque (N-m)
50	2.87
75	2.47
100	2.17
125	2.38
150	2.16
175	1.98
200	1.82

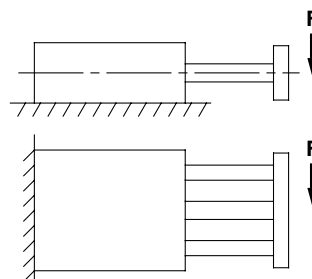

### Plate non-rotating accuracy (θ)

Non-rotating accuracy  
±0.09°

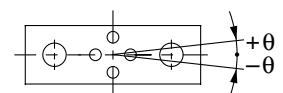

Refer to page 962 for deflection data.

## Dimensions/LXPB5SA

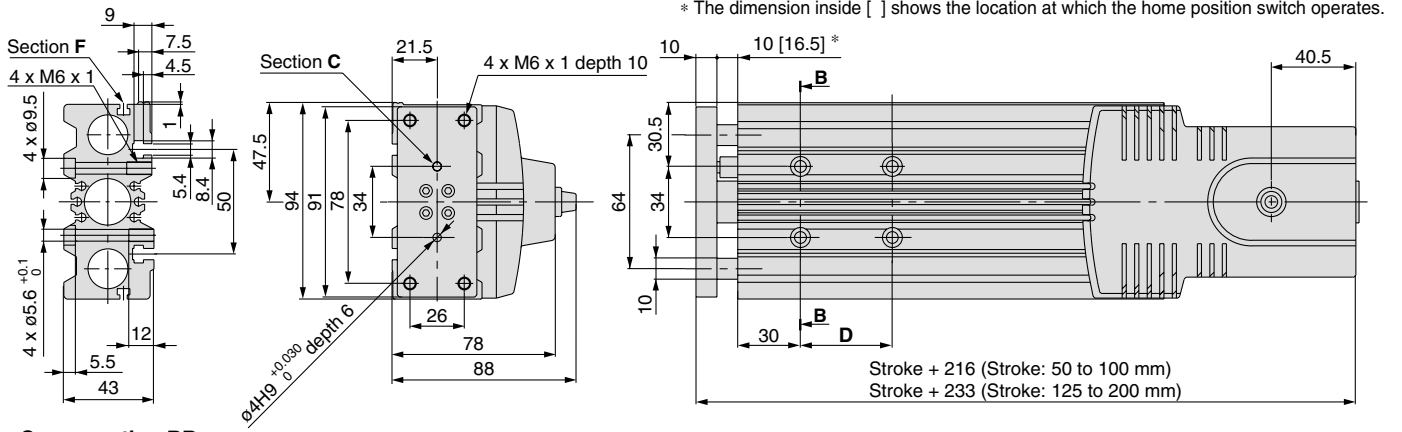

Cross section BB

### Brake electrical circuit

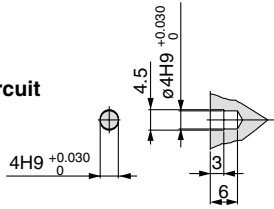
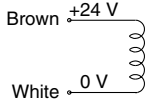

Section C detail  
(Scale: 2/1)

Motor wire (300 mm)  
Brake wire (300 mm)  
Photo micro sensor wire (300 mm)

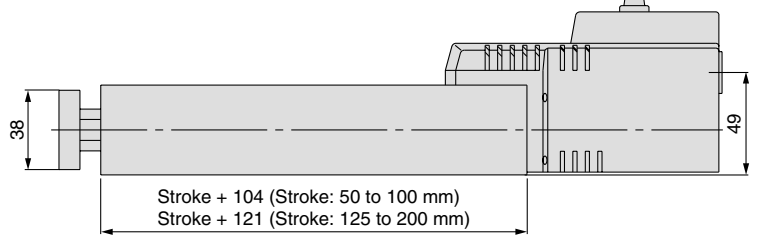

Note) A contact protection circuit is required when connecting a brake.

Model	D	E
LXPB5SA- 50□B	44	52
LXPB5SA- 75□B		
LXPB5SA-100□B		
LXPB5SA-125□B		
LXPB5SA-150□B	120	90
LXPB5SA-175□B		
LXPB5SA-200□B		

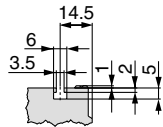

Section F detail  
(Scale: 2/1)

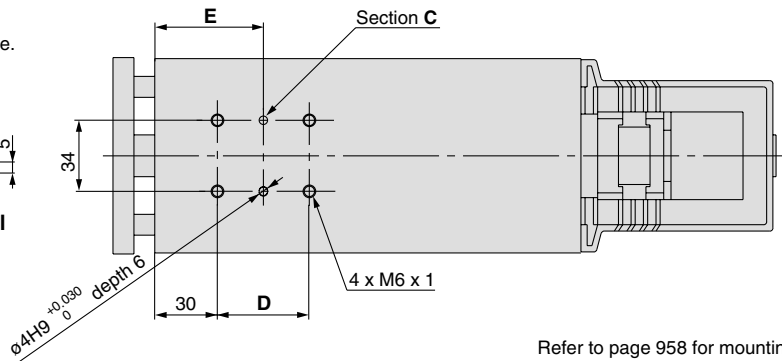

Refer to page 958 for mounting.

## Positioning Time Guide (for Vertical Mount)

### For transfer load of 0 kg

Positioning distance (mm)		Positioning time (sec)				
		1	10	50	100	200
Speed (mm/s)	10	0.2	1.1	5.1	10.1	20.1
	50	0.1	0.3	1.1	2.1	4.1
	100	0.1	0.2	0.6	1.1	2.1

### For transfer load of 4 kg

Positioning distance (mm)		Positioning time (sec)				
		1	10	50	100	200
Speed (mm/s)	10	0.2	1.1	5.1	10.1	20.1
	50	0.1	0.3	1.1	2.1	4.1
	100	0.1	0.3	0.7	1.2	2.2

### For transfer load of 2 kg

Positioning distance (mm)		Positioning time (sec)				
		1	10	50	100	200
Speed (mm/s)	10	0.2	1.1	5.1	10.1	20.1
	50	0.1	0.3	1.1	2.1	4.1
	100	0.1	0.2	0.6	1.1	2.1

Refer to page 960 for acceleration time.

- LJ1
- LG1
- LTF
- LC1
- LC7
- LC8
- LXF
- LXP
- LXS
- LC6□
- LZ□
- LC3F2
- X□
- D-□
- E-MY

# Guide Rod Type 5 Phase Stepper Motor With Motor Brake Series LXP

Ball  
Bushing

Slide Screw  
Ø 8 mm/12 mm lead

## How to Order

LXPB5 SB - 100 B - M9N 1

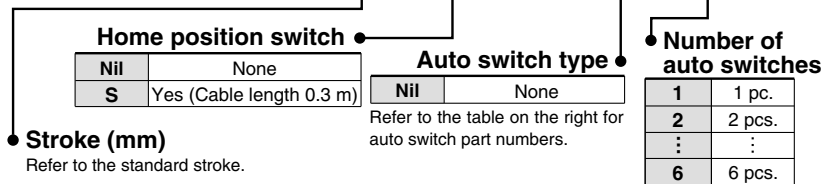

## Auto switch types

Symbol	Model	Wiring/Output type	Lead wire length (m)	Contact
Nil	Without auto switch			
M9N	D-M9N	3 wire/NPN	0.5	N.O. (A contact)
M9P	D-M9P	3 wire/PNP	0.5	N.O. (A contact)
M9B	D-M9B	2 wire	0.5	N.O. (A contact)
F9G	D-F9G	3 wire/NPN	0.5	N.C. (B contact)
F9H	D-F9H	3 wire/PNP	0.5	N.C. (B contact)
F9GL	D-F9GL	3 wire/NPN	3	N.C. (B contact)
F9HL	D-F9HL	3 wire/PNP	3	N.C. (B contact)
M9NL	D-M9NL	3 wire/NPN	3	N.O. (A contact)
M9PL	D-M9PL	3 wire/PNP	3	N.O. (A contact)
M9BL	D-M9BL	2 wire	3	N.O. (A contact)

## Specifications

Standard stroke (mm)		50	75	100	125	150	175	200	
Performance	Body mass (kg)	2.2	2.4	2.5	2.8	3.0	3.1	3.3	
	Operating temperature range (°C)	5 to 40 (No condensation)							
	Work load (kg)	2 horizontal/2 vertical <sup>Note 1)</sup>							
	Speed (mm/s)	to 200 <sup>Note 2)</sup>							
	Positioning repeatability (mm)	±0.05							
Main parts	Motor	5 phase stepper motor (with brake)							
	Lead screw	Slide screw ø8 mm, 12 mm lead							
	Guide	Ball bushing							
	Electromagnetic brake	Model	De-energized operating type						
		Static torque (N-m)	0.1 or more						
Rated voltage (V)		24 DC ±5%							
Home position switch	Power consumption (W)	5							
	Model	Photo micro sensor EE-SX673 (Refer to page 1084 for details.)							
Driver	Model	LC6D-507AD-□ (Refer to page 963 for details.)							

Note 1) Based on the operating conditions, establish a separate guide when exceeding the maximum allowable lateral load.

Note 2) Since vibration may increase with low speed operation, set the driver to be driven in half-step mode, and use 12 mm/s or more as a guide for speed.

## Lifter Operation Range

This is the operating range for ball bushings. Use within the allowable thrust range.

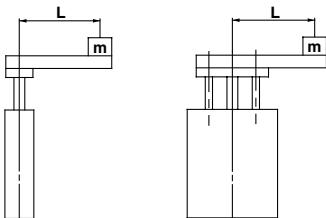

### 50 to 200 mm stroke

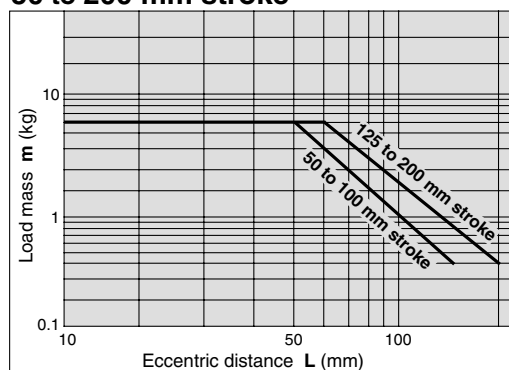

## Operating Conditions

### Allowable lateral load (F)

Stroke	Load (N)
50	42
75	42
100	40
125	42
150	32
175	24
200	17

### Allowable plate rotation torque (T)

Stroke	Torque (N-m)
50	2.87
75	2.47
100	2.17
125	2.38
150	2.16
175	1.98
200	1.82

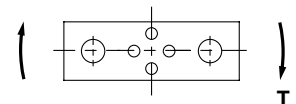
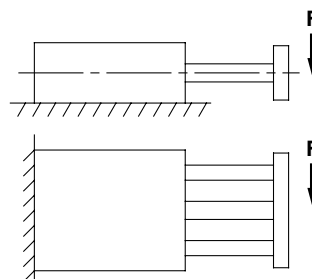

### Plate non-rotating accuracy (θ)

Non-rotating accuracy  
±0.09°

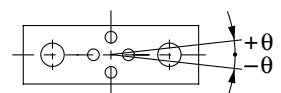

Refer to page 962 for deflection data.



## Dimensions/LXPB5SB

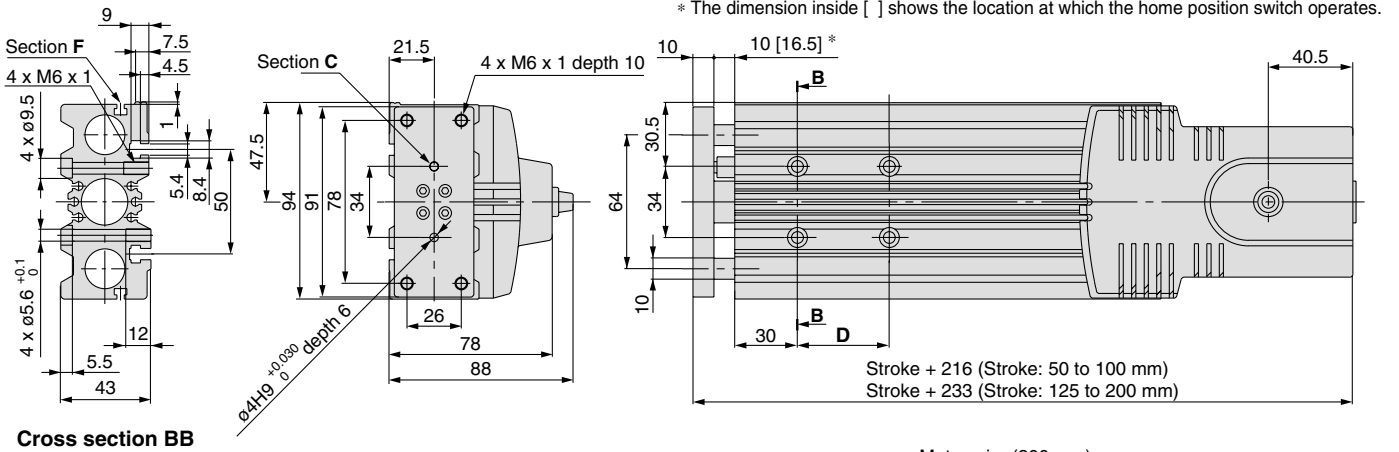

Cross section BB

### Brake electrical circuit

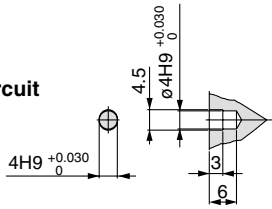
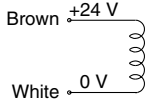

Section C detail  
(Scale: 2/1)

Motor wire (300 mm)  
Brake wire (300 mm)  
Photo micro sensor wire (300 mm)

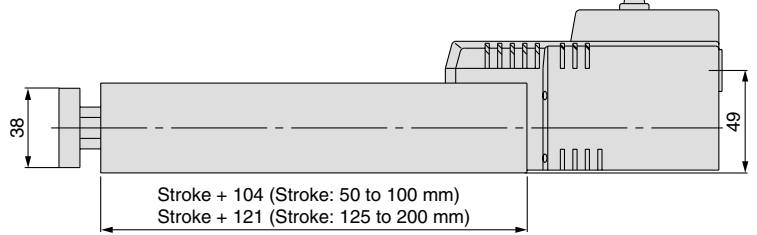

Note) A contact protection circuit is required when connecting a brake.

Model	D	E
LXPB5SB- 50□B	44	52
LXPB5SB- 75□B		
LXPB5SB-100□B		
LXPB5SB-125□B		
LXPB5SB-150□B	120	90
LXPB5SB-175□B		
LXPB5SB-200□B		

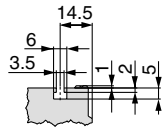

Section F detail  
(Scale: 2/1)

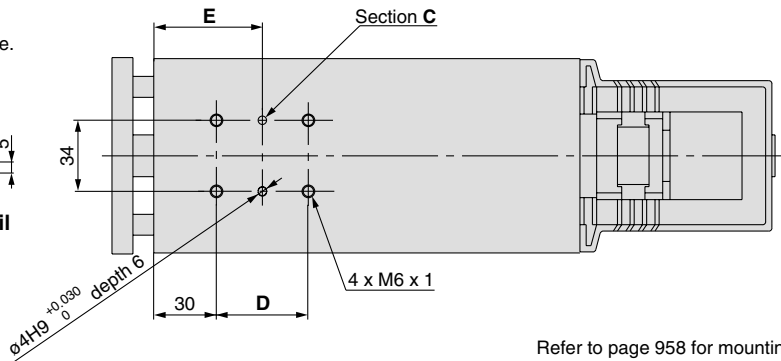

Refer to page 958 for mounting.

## Positioning Time Guide (for Vertical Mount)

### For transfer load of 0 kg

Positioning distance (mm)		Positioning time (sec)				
		1	10	50	100	200
Speed (mm/s)	50	0.1	0.3	1.1	2.1	4.1
	100	0.1	0.2	0.6	1.1	2.1
	200	0.1	0.1	0.3	0.6	1.1

### For transfer load of 2 kg

Positioning distance (mm)		Positioning time (sec)				
		1	10	50	100	200
Speed (mm/s)	50	0.1	0.2	1.1	2.1	4.1
	100	0.1	0.2	0.6	1.1	2.1
	200	0.1	0.2	0.4	0.6	1.1

### For transfer load of 1 kg

Positioning distance (mm)		Positioning time (sec)				
		1	10	50	100	200
Speed (mm/s)	50	0.1	0.3	1.1	2.1	4.1
	100	0.1	0.2	0.6	1.1	2.1
	200	0.1	0.1	0.3	0.6	1.1

Refer to page 960 for acceleration time.

LJ1

LG1

LTF

LC1

LC7

LC8

LXF

LXP

LXS

LC6□

LZ□

LC3F2

X□

D-□

E-MY

# High Rigidity Slide Table Type

## 2 Phase Stepper Motor

## Without Motor Brake

# Series LXS

High Rigidity  
Direct Acting  
Guide

Ball Screw  
ø8 mm/2 mm lead

### How to Order

**LXSH2BC** - **100** - **M9N** **1**

**Stroke (mm)**  
Refer to the standard stroke.

**Home position switch**

Nil	None
S	Yes (Cable length 0.3 m)

**Auto/Proximity switch type**

Nil	None
-----	------

Refer to the table on the right for auto/proximity switch part numbers.

**Number of auto/proximity switches**

1	1 pc.
2	2 pcs.
⋮	⋮
6	6 pcs.

When using both auto and proximity switches, list the proximity switch part number after the auto switch part number.  
Example) M9N1G2

### Specifications

Standard stroke (mm)		50	75	100	125	150
Performance	Body mass (kg)	1.9	2.1	2.3	2.5	2.7
	Operating temperature range (°C)	5 to 40 (No condensation)				
	Work load (kg)	10 (4) horizontal/5 (4) vertical (Note 1)				
	Speed (mm/s)	to 30 (Note 2)				
	Positioning repeatability (mm)	±0.03				
Main parts	Motor	2 phase stepper motor (without brake)				
	Lead screw	Ball screw ø8 mm, 2 mm lead				
	Guide	High rigidity direct acting guide				
Home position switch	Model	Photo micro sensor EE-SX673 (Refer to page 1084 for details.)				
Driver	Model	LC6D-220AD-□ (Refer to page 964 for details.)				
Positioning driver	Model	LC6C-220AD (Refer to page 967 for details.)				

Note 1) When mounting a work piece to the actuator's end plate, its mass should be within the value inside ( ).

Note 2) Since vibration may increase with low speed operation, set the driver to be driven in half-step mode, and use 2 mm/s or more as a guide for speed.

### Allowable Moment (N·m)

#### Allowable static moment

Pitching	15.7
Rolling	15.7
Yawing	7.84

- m** : Transfer load (kg)
- L1, L2** : Overhang to work piece center of gravity (mm)
- a** : Work piece acceleration (mm/sec<sup>2</sup>)
- Me** : Dynamic moment

#### Allowable dynamic moment

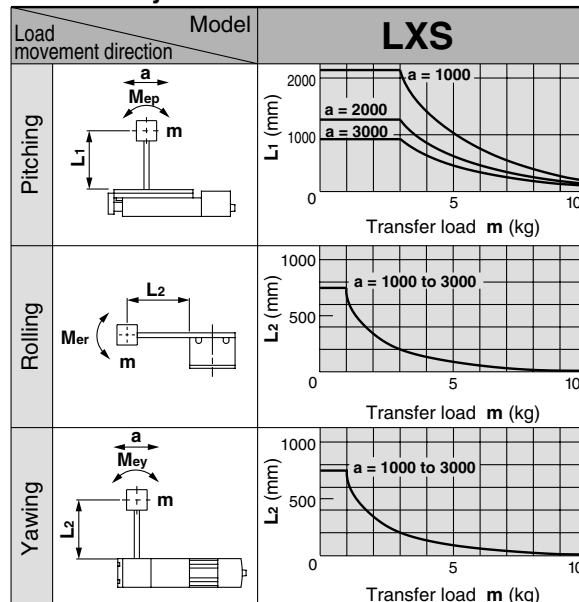

Refer to page 962 for deflection data.

### Auto switch types

Symbol	Model	Wiring/Output type	Lead wire length (m)	Contact
Nil	Without auto switch			
M9N	D-M9N	3 wire/NPN	0.5	N.O. (A contact)
M9P	D-M9P	3 wire/PNP	0.5	N.O. (A contact)
M9B	D-M9B	2 wire	0.5	N.O. (A contact)
F9G	D-F9G	3 wire/NPN	0.5	N.C. (B contact)
F9H	D-F9H	3 wire/PNP	0.5	N.C. (B contact)
F9GL	D-F9GL	3 wire/NPN	3	N.C. (B contact)
F9HL	D-F9HL	3 wire/PNP	3	N.C. (B contact)
M9NL	D-M9NL	3 wire/NPN	3	N.O. (A contact)
M9PL	D-M9PL	3 wire/PNP	3	N.O. (A contact)
M9BL	D-M9BL	2 wire	3	N.O. (A contact)

### Proximity switch types

Symbol	Model	Wiring/Output type	Lead wire length (m)	Contact
GN	With sensor plate, without proximity switch	—	—	—
G	GX-F8A	3 wire/NPN	1	N.O. (A contact)
GD	GX-F8AI	3 wire/NPN	1	N.O. (A contact)
GB	GX-F8B	3 wire/NPN	1	N.C. (B contact)
GDB	GX-F8BI	3 wire/NPN	1	N.C. (B contact)
GU	GXL-8FU	2 wire/solid state	1	N.O. (A contact)
GUB	GXL-8FUB	2 wire/solid state	1	N.C. (B contact)

\* Refer to page 1082 for detailed specifications of proximity switches.



**Made to order specifications**  
(For details, refer to page 999)

Symbol	Specifications
X20	AC servomotor specification
X60	Low particle generation specification

# High Rigidity Slide Table Type 2 Phase Stepper Motor/Without Motor Brake **Series LXS**

## Dimensions/LXSH2BC

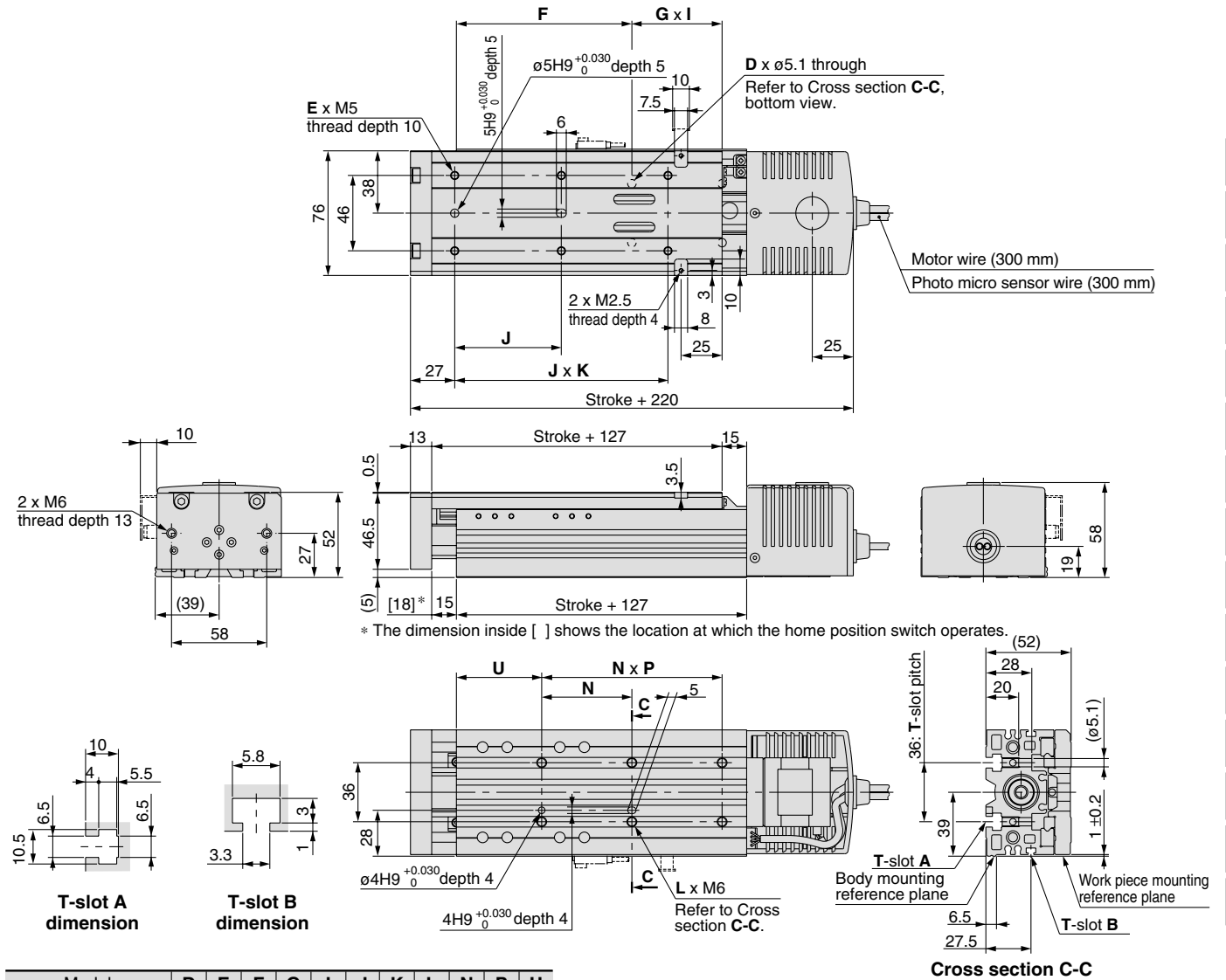

- LJ1
- LG1
- LTF
- LC1
- LC7
- LC8
- LXF
- LXP
- LXS**
- LC6
- LZ
- LC3F2
- X
- D-
- E-MY

Model	D	E	F	G	I	J	K	L	N	P	U
LXSH2BC- 50	4	6	107	55	1	65	2	6	55	2	52
LXSH2BC- 75	4	6	112	65	1	75	2	6	65	2	47
LXSH2BC-100	4	8	122	75	1	65	3	6	75	2	47
LXSH2BC-125	4	8	132	85	1	70	3	6	85	2	47
LXSH2BC-150	6	8	112	65	2	75	3	8	65	3	47

Refer to page 959 for mounting.

## Positioning Time Guide (for Horizontal Mount)

### For transfer load of 0 kg

		Positioning time (sec)				
		1	10	50	100	150
Speed (mm/s)	10	0.2	1.1	5.1	10.1	15.1
	20	0.1	0.6	2.6	5.1	7.6
	30	0.1	0.4	1.7	3.4	5.1

### For transfer load of 10 kg

		Positioning time (sec)				
		1	10	50	100	150
Speed (mm/s)	10	0.2	1.1	5.1	10.1	15.1
	20	0.1	0.6	2.6	5.1	7.6
	30	0.1	0.4	1.7	3.4	5.1

### For transfer load of 5 kg

		Positioning time (sec)				
		1	10	50	100	150
Speed (mm/s)	10	0.2	1.1	5.1	10.1	15.1
	20	0.1	0.6	2.6	5.1	7.6
	30	0.1	0.4	1.7	3.4	5.1

Refer to page 961 for acceleration time.

# High Rigidity Slide Table Type

## 2 Phase Stepper Motor

## Without Motor Brake

# Series LXS

High Rigidity  
Direct Acting  
Guide

Ball Screw  
ø8 mm/5 mm lead

### How to Order

**LXSH2BD - 100 - M9N 1**

**Stroke (mm)**  
Refer to the standard stroke.

**Home position switch**

Nil	None
S	Yes (Cable length 0.3 m)

**Auto/Proximity switch type**

Nil	None
-----	------

Refer to the table on the right for auto/proximity switch part numbers.

**Number of auto/proximity switches**

1	1 pc.
2	2 pcs.
⋮	⋮
6	6 pcs.

When using both auto and proximity switches, list the proximity switch part number after the auto switch part number.  
Example) M9N1G2

### Specifications

Standard stroke (mm)		50	75	100	125	150
Performance	Body mass (kg)	1.9	2.1	2.3	2.5	2.7
	Operating temperature range (°C)	5 to 40 (No condensation)				
	Work load (kg)	10 (4) horizontal/5 (4) vertical (Note 1)				
	Speed (mm/s)	to 80 (Note 2)				
	Positioning repeatability (mm)	±0.03				
Main parts	Motor	2 phase stepper motor (without brake)				
	Lead screw	Ball screw ø8 mm, 5 mm lead				
	Guide	High rigidity direct acting guide				
Home position switch	Model	Photo micro sensor EE-SX673 (Refer to page 1084 for details.)				
Driver	Model	LC6D-220AD-□ (Refer to page 964 for details.)				
Positioning driver	Model	LC6C-220AD (Refer to page 967 for details.)				

Note 1) When mounting a work piece to the actuator's end plate, its mass should be within the value inside ( ).  
Note 2) Since vibration may increase with low speed operation, set the driver to be driven in half-step mode, and use 5 mm/s or more as a guide for speed.

### Allowable Moment (N·m)

#### Allowable static moment

Pitching	15.7
Rolling	15.7
Yawing	7.84

**m** : Transfer load (kg)  
**L1, L2** : Overhang to work piece center of gravity (mm)  
**a** : Work piece acceleration (mm/sec<sup>2</sup>)  
**Me** : Dynamic moment

#### Allowable dynamic moment

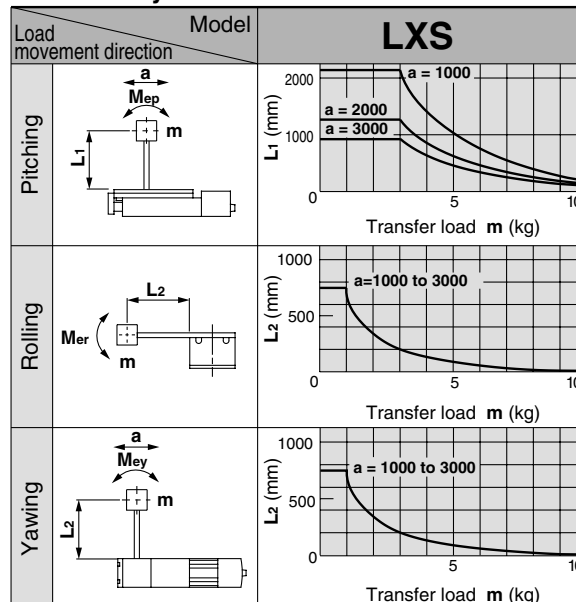

Refer to page 962 for deflection data.

### Auto switch types

Symbol	Model	Wiring/Output type	Lead wire length (m)	Contact
Nil	Without auto switch			
M9N	D-M9N	3 wire/NPN	0.5	N.O. (A contact)
M9P	D-M9P	3 wire/PNP	0.5	N.O. (A contact)
M9B	D-M9B	2 wire	0.5	N.O. (A contact)
F9G	D-F9G	3 wire/NPN	0.5	N.C. (B contact)
F9H	D-F9H	3 wire/PNP	0.5	N.C. (B contact)
F9GL	D-F9GL	3 wire/NPN	3	N.C. (B contact)
F9HL	D-F9HL	3 wire/PNP	3	N.C. (B contact)
M9NL	D-M9NL	3 wire/NPN	3	N.O. (A contact)
M9PL	D-M9PL	3 wire/PNP	3	N.O. (A contact)
M9BL	D-M9BL	2 wire	3	N.O. (A contact)

### Proximity switch types

Symbol	Model	Wiring/Output type	Lead wire length (m)	Contact
GN	With sensor plate, without proximity switch	—	—	—
G	GX-F8A	3 wire/NPN	1	N.O. (A contact)
GD	GX-F8AI	3 wire/NPN	1	N.O. (A contact)
GB	GX-F8B	3 wire/NPN	1	N.C. (B contact)
GDB	GX-F8BI	3 wire/NPN	1	N.C. (B contact)
GU	GXL-8FU	2 wire/solid state	1	N.O. (A contact)
GUB	GXL-8FUB	2 wire/solid state	1	N.C. (B contact)

\* Refer to page 1082 for detailed specifications of proximity switches.



**Made to order specifications**  
(For details, refer to page 999)

Symbol	Specifications
X20	AC servomotor specification
X60	Low particle generation specification

# High Rigidity Slide Table Type 2 Phase Stepper Motor/Without Motor Brake **Series LXS**

## Dimensions/LXSH2BD

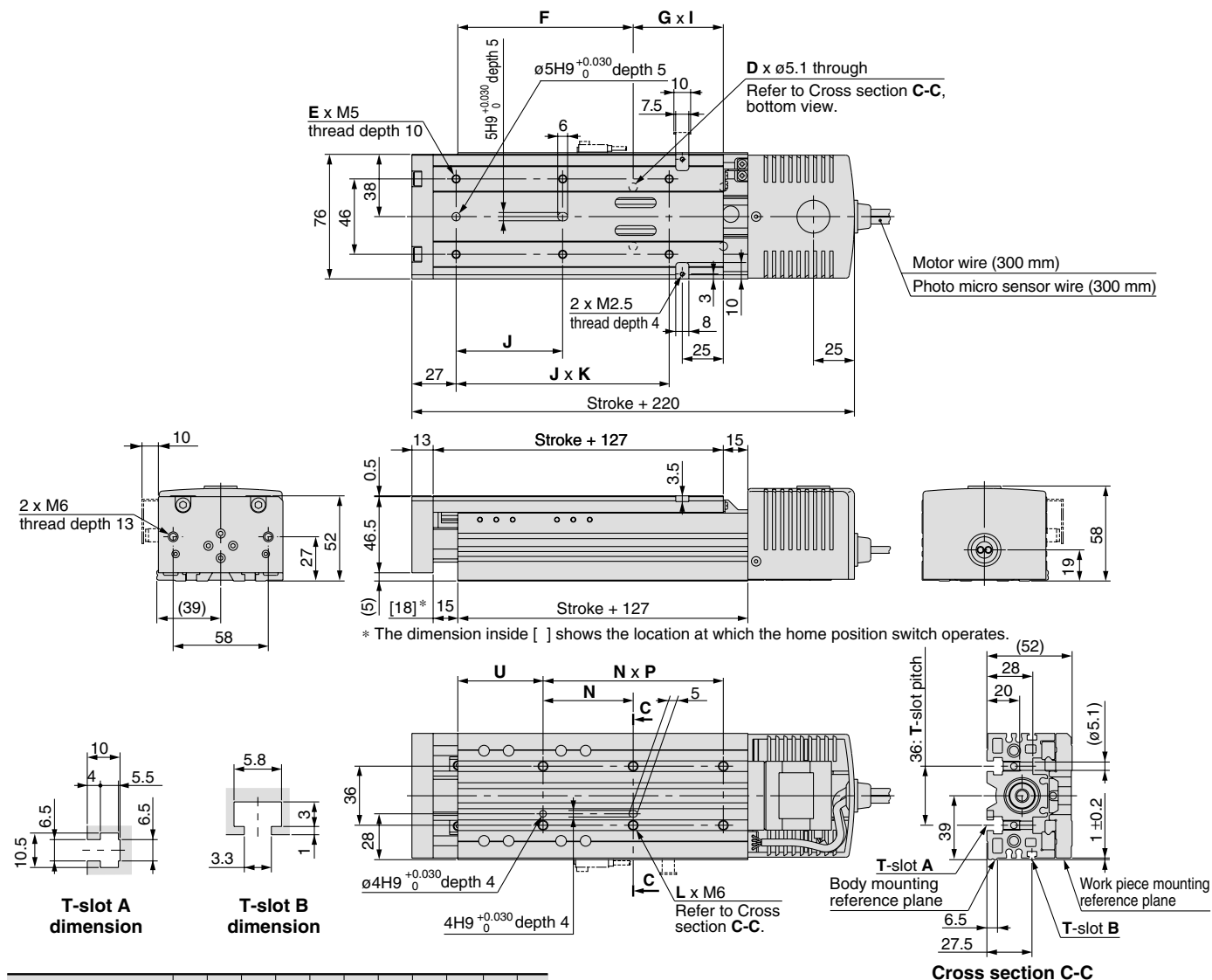

Model	D	E	F	G	I	J	K	L	N	P	U
LXSH2BD- 50	4	6	107	55	1	65	2	6	55	2	52
LXSH2BD- 75	4	6	112	65	1	75	2	6	65	2	47
LXSH2BD-100	4	8	122	75	1	65	3	6	75	2	47
LXSH2BD-125	4	8	132	85	1	70	3	6	85	2	47
LXSH2BD-150	6	8	112	65	2	75	3	8	65	3	47

Refer to page 959 for mounting.

## Positioning Time Guide (for Horizontal Mount)

### For transfer load of 0 kg

Positioning distance (mm)		Positioning time (sec)				
		1	10	50	100	150
Speed (mm/s)	10	0.2	1.1	5.1	10.1	15.1
	40	0.1	0.3	1.3	2.6	3.8
	80	0.4	0.2	0.7	1.3	1.9

### For transfer load of 10 kg

Positioning distance (mm)		Positioning time (sec)				
		1	10	50	100	150
Speed (mm/s)	10	0.2	1.1	5.1	10.1	15.1
	40	0.1	0.3	1.3	2.6	3.8
	80	0.1	0.2	0.7	1.3	1.9

### For transfer load of 5 kg

Positioning distance (mm)		Positioning time (sec)				
		1	10	50	100	150
Speed (mm/s)	10	0.2	1.1	5.1	10.1	15.1
	40	0.1	0.3	1.3	2.6	3.8
	80	0.1	0.2	0.7	1.3	1.9

Refer to page 961 for acceleration time.

# High Rigidity Slide Table Type

## 2 Phase Stepper Motor

## Without Motor Brake

# Series LXS

High Rigidity  
Direct Acting  
Guide

Slide Screw  
ø8 mm/6 mm lead

### How to Order

LXSH2 **SA** - **100** - **M9N** **1**

**Stroke (mm)**  
Refer to the standard stroke.

**Home position switch**

Nil	None
S	Yes (Cable length 0.3 m)

**Auto/Proximity switch type**

Nil	None
-----	------

Refer to the table on the right for auto/proximity switch part numbers.

**Number of auto/proximity switches**

1	1 pc.
2	2 pcs.
⋮	⋮
6	6 pcs.

When using both auto and proximity switches, list the proximity switch part number after the auto switch part number.  
Example) M9N1G2

### Specifications

Standard stroke (mm)		50	75	100	125	150
Performance	Body mass (kg)	1.9	2.1	2.3	2.5	2.7
	Operating temperature range (°C)	5 to 40 (No condensation)				
	Work load (kg)	9 (4) horizontal/4 (4) vertical Note 1)				
	Speed (mm/s)	to 100 Note 2)				
	Positioning repeatability (mm)	±0.05				
Main parts	Motor	2 phase stepper motor (without brake)				
	Lead screw	Slide screw ø8 mm, 6 mm lead				
	Guide	High rigidity direct acting guide				
Home position switch	Model	Photo micro sensor EE-SX673 (Refer to page 1084 for details.)				
	Driver	Model	LC6D-220AD-□ (Refer to page 964 for details.)			
Positioning driver	Model	LC6C-220AD (Refer to page 967 for details.)				

Note 1) When mounting a work piece to the actuator's end plate, its mass should be within the value inside ( ).

Note 2) Since vibration may increase with low speed operation, set the driver to be driven in half-step mode, and use 6 mm/s or more as a guide for speed.

### Allowable Moment (N·m)

#### Allowable static moment

Pitching	15.7
Rolling	15.7
Yawing	7.84

**m** : Transfer load (kg)  
**L1, L2** : Overhang to work piece center of gravity (mm)  
**a** : Work piece acceleration (mm/sec<sup>2</sup>)  
**Me** : Dynamic moment

#### Allowable dynamic moment

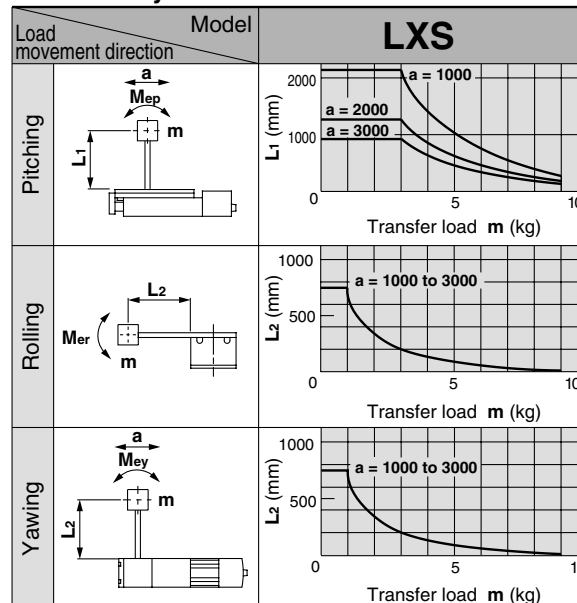

Refer to page 962 for deflection data.

### Auto switch types

Symbol	Model	Wiring/Output type	Lead wire length (m)	Contact
Nil	Without auto switch			
M9N	D-M9N	3 wire/NPN	0.5	N.O. (A contact)
M9P	D-M9P	3 wire/PNP	0.5	N.O. (A contact)
M9B	D-M9B	2 wire	0.5	N.O. (A contact)
F9G	D-F9G	3 wire/NPN	0.5	N.C. (B contact)
F9H	D-F9H	3 wire/PNP	0.5	N.C. (B contact)
F9GL	D-F9GL	3 wire/NPN	3	N.C. (B contact)
F9HL	D-F9HL	3 wire/PNP	3	N.C. (B contact)
M9NL	D-M9NL	3 wire/NPN	3	N.O. (A contact)
M9PL	D-M9PL	3 wire/PNP	3	N.O. (A contact)
M9BL	D-M9BL	2 wire	3	N.O. (A contact)

### Proximity switch types

Symbol	Model	Wiring/Output type	Lead wire length (m)	Contact
GN	With sensor plate, without proximity switch	—	—	—
G	GX-F8A	3 wire/NPN	1	N.O. (A contact)
GD	GX-F8AI	3 wire/NPN	1	N.O. (A contact)
GB	GX-F8B	3 wire/NPN	1	N.C. (B contact)
GDB	GX-F8BI	3 wire/NPN	1	N.C. (B contact)
GU	GXL-8FU	2 wire/solid state	1	N.O. (A contact)
GUB	GXL-8FUB	2 wire/solid state	1	N.C. (B contact)

\* Refer to page 1082 for detailed specifications of proximity switches.

# High Rigidity Slide Table Type 2 Phase Stepper Motor/Without Motor Brake **Series LXS**

## Dimensions/LXSH2SA

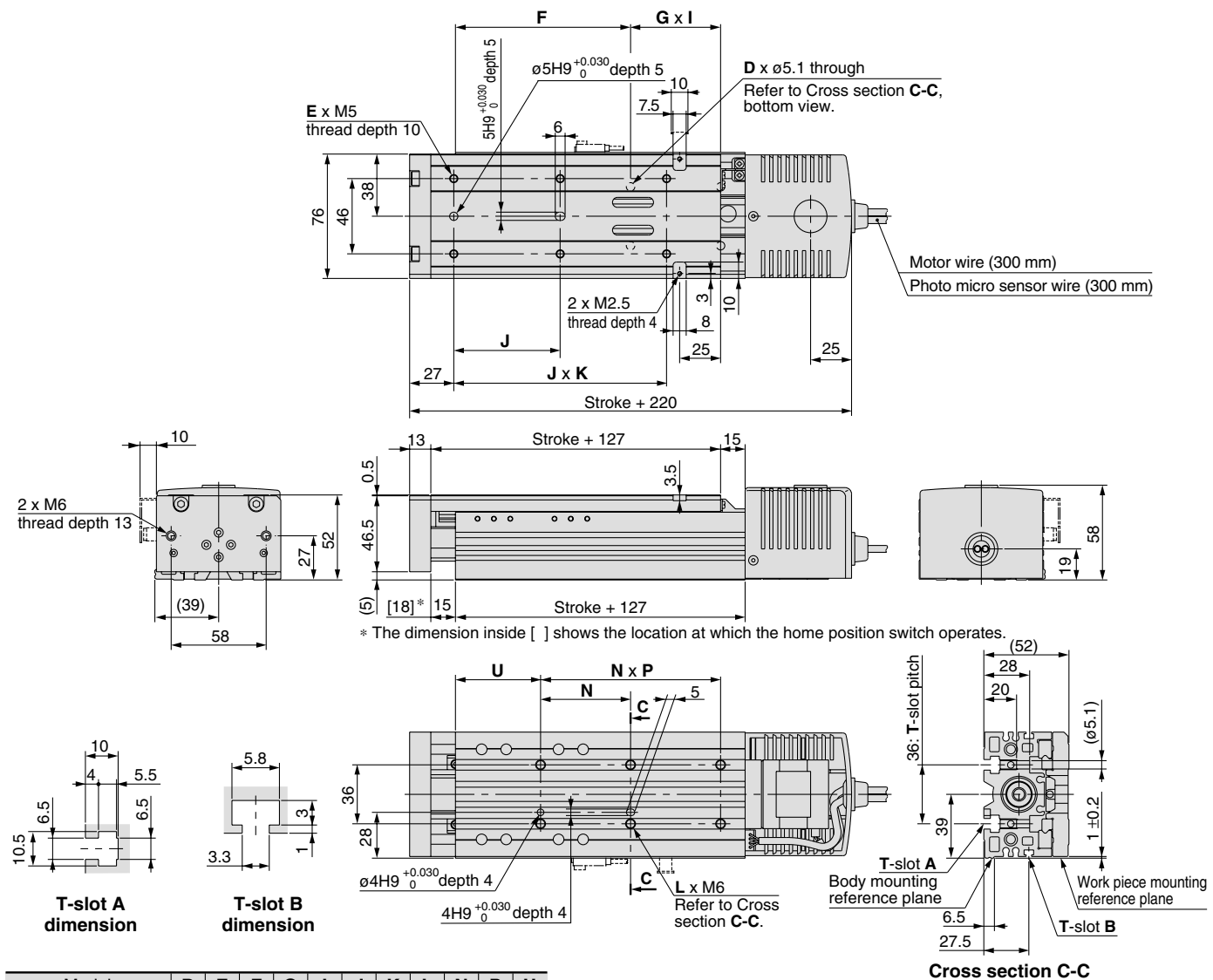

Model	D	E	F	G	I	J	K	L	N	P	U
LXSH2SA- 50	4	6	107	55	1	65	2	6	55	2	52
LXSH2SA- 75	4	6	112	65	1	75	2	6	65	2	47
LXSH2SA-100	4	8	122	75	1	65	3	6	75	2	47
LXSH2SA-125	4	8	132	85	1	70	3	6	85	2	47
LXSH2SA-150	6	8	112	65	2	75	3	8	65	3	47

Refer to page 959 for mounting.

## Positioning Time Guide (for Horizontal Mount)

### For transfer load of 0 kg

		Positioning time (sec)				
		1	10	50	100	150
Speed (mm/s)	10	0.2	1.1	5.1	10.1	15.1
	50	0.1	0.3	1.1	2.1	3.1
	100	0.1	0.2	0.6	1.1	1.6

### For transfer load of 9 kg

		Positioning time (sec)				
		1	10	50	100	150
Speed (mm/s)	10	0.2	1.1	5.1	10.1	15.1
	50	0.1	0.3	1.1	2.1	3.1
	100	0.1	0.2	0.6	1.1	1.6

### For transfer load of 4.5 kg

		Positioning time (sec)				
		1	10	50	100	150
Speed (mm/s)	10	0.2	1.1	5.1	10.1	15.1
	50	0.1	0.3	1.1	2.1	3.1
	100	0.1	0.2	0.6	1.1	1.6

Refer to page 960 for acceleration time.

# High Rigidity Slide Table Type

## 2 Phase Stepper Motor

## Without Motor Brake

# Series LXS

High Rigidity  
Direct Acting  
Guide

Slide Screw  
∅8 mm/12 mm lead

### How to Order

**LXSH2 SB - 100 - M9N 1**

**Stroke (mm)**  
Refer to the standard stroke.

**Home position switch**

Nil	None
S	Yes (Cable length 0.3 m)

**Auto/Proximity switch type**

Nil	None
-----	------

Refer to the table on the right for auto/proximity switch part numbers.

**Number of auto/proximity switches**

1	1 pc.
2	2 pcs.
⋮	⋮
6	6 pcs.

When using both auto and proximity switches, list the proximity switch part number after the auto switch part number.  
Example) M9N1G2

### Specifications

Standard stroke (mm)		50	75	100	125	150
Performance	Body mass (kg)	1.9	2.1	2.3	2.5	2.7
	Operating temperature range (°C)	5 to 40 (No condensation)				
	Work load (kg)	4.5 (4) horizontal/2 (2) vertical <small>Note 1)</small>				
	Speed (mm/s)	to 200 <small>Note 2)</small>				
	Positioning repeatability (mm)	±0.05				
Main parts	Motor	2 phase stepper motor (without brake)				
	Lead screw	Slide screw ∅8 mm, 12 mm lead				
	Guide	High rigidity direct acting guide				
Home position switch	Model	Photo micro sensor EE-SX673 (Refer to page 1084 for details.)				
Driver	Model	LC6D-220AD-□ (Refer to page 964 for details.)				
Positioning driver	Model	LC6C-220AD (Refer to page 967 for details.)				

Note 1) When mounting a work piece to the actuator's end plate, its mass should be within the value inside ( ).

Note 2) Since vibration may increase with low speed operation, set the driver to be driven in half-step mode, and use 12 mm/s or more as a guide for speed.

### Allowable Moment (N·m)

#### Allowable static moment

Pitching	15.7
Rolling	15.7
Yawing	7.84

**m** : Transfer load (kg)  
**L1, L2** : Overhang to work piece center of gravity (mm)  
**a** : Work piece acceleration (mm/sec<sup>2</sup>)  
**Me** : Dynamic moment

#### Allowable dynamic moment

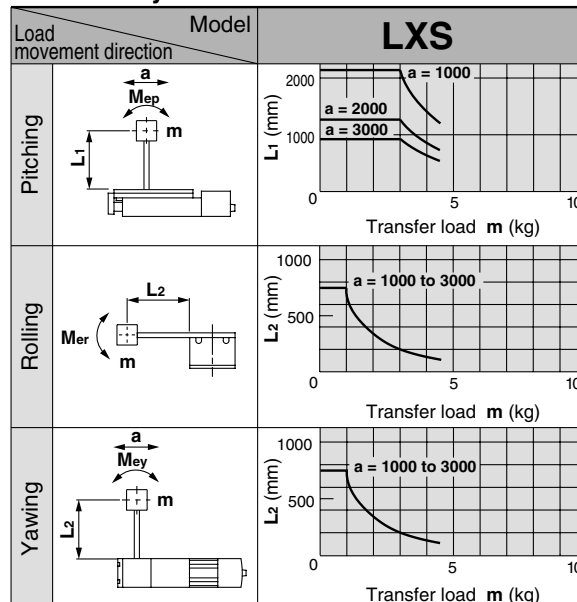

Refer to page 962 for deflection data.

#### Auto switch types

Symbol	Model	Wiring/Output type	Lead wire length (m)	Contact
Nil	Without auto switch			
M9N	D-M9N	3 wire/NPN	0.5	N.O. (A contact)
M9P	D-M9P	3 wire/PNP	0.5	N.O. (A contact)
M9B	D-M9B	2 wire	0.5	N.O. (A contact)
F9G	D-F9G	3 wire/NPN	0.5	N.C. (B contact)
F9H	D-F9H	3 wire/PNP	0.5	N.C. (B contact)
F9GL	D-F9GL	3 wire/NPN	3	N.C. (B contact)
F9HL	D-F9HL	3 wire/PNP	3	N.C. (B contact)
M9NL	D-M9NL	3 wire/NPN	3	N.O. (A contact)
M9PL	D-M9PL	3 wire/PNP	3	N.O. (A contact)
M9BL	D-M9BL	2 wire	3	N.O. (A contact)

#### Proximity switch types

Symbol	Model	Wiring/Output type	Lead wire length (m)	Contact
GN	With sensor plate, without proximity switch	—	—	—
G	GX-F8A	3 wire/NPN	1	N.O. (A contact)
GD	GX-F8AI	3 wire/NPN	1	N.O. (A contact)
GB	GX-F8B	3 wire/NPN	1	N.C. (B contact)
GDB	GX-F8BI	3 wire/NPN	1	N.C. (B contact)
GU	GXL-8FU	2 wire/solid state	1	N.O. (A contact)
GUB	GXL-8FUB	2 wire/solid state	1	N.C. (B contact)

\* Refer to page 1082 for detailed specifications of proximity switches.



# High Rigidity Slide Table Type 2 Phase Stepper Motor/Without Motor Brake **Series LXS**

## Dimensions/LXSH2SB

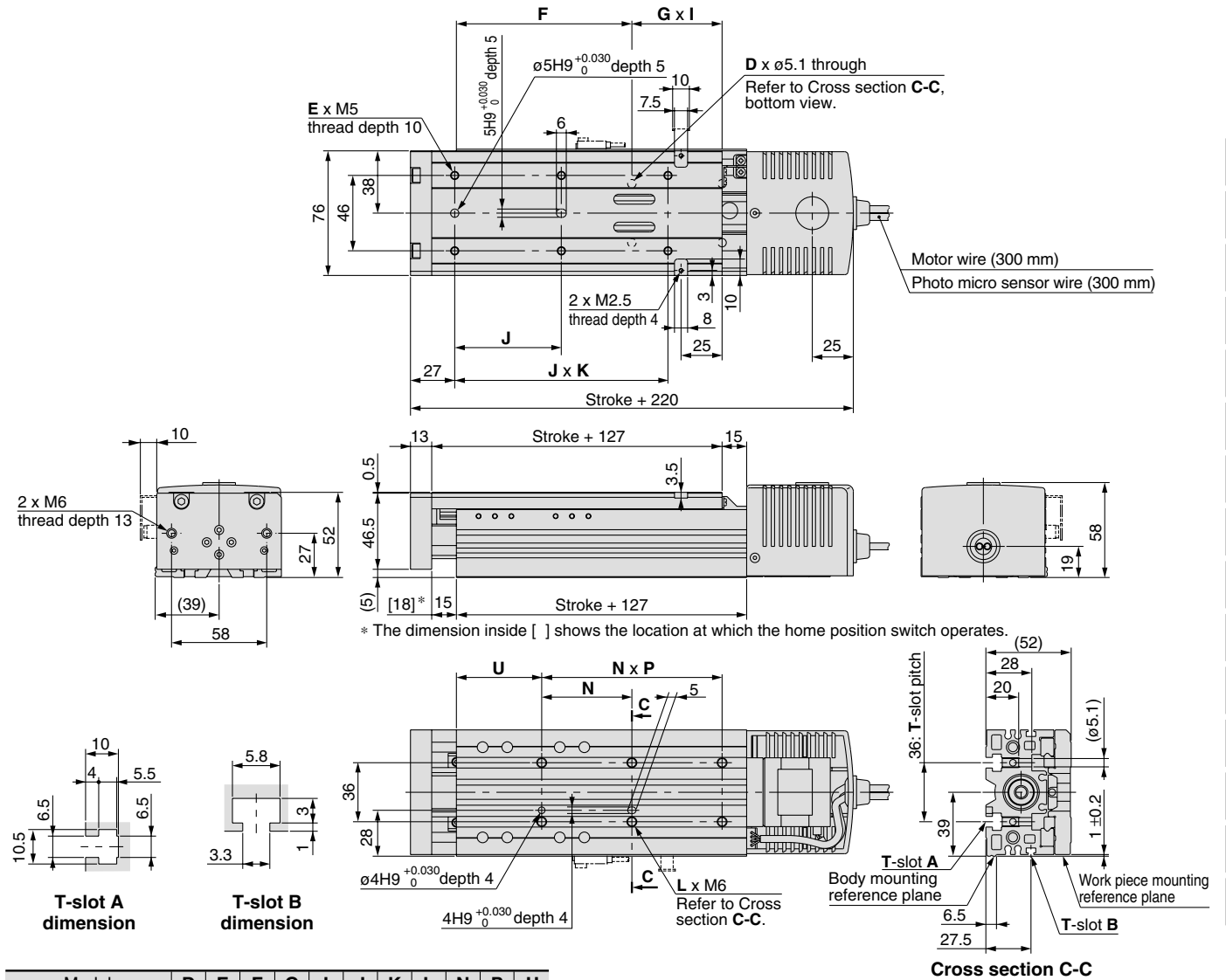

Model	D	E	F	G	I	J	K	L	N	P	U
LXSH2SB- 50	4	6	107	55	1	65	2	6	55	2	52
LXSH2SB- 75	4	6	112	65	1	75	2	6	65	2	47
LXSH2SB-100	4	8	122	75	1	65	3	6	75	2	47
LXSH2SB-125	4	8	132	85	1	70	3	6	85	2	47
LXSH2SB-150	6	8	112	65	2	75	3	8	65	3	47

Refer to page 959 for mounting.

## Positioning Time Guide (for Horizontal Mount)

### For transfer load of 0 kg

Positioning distance (mm)		Positioning time (sec)				
		1	10	50	100	150
Speed (mm/s)	50	0.1	0.3	1.1	2.1	3.1
	100	0.1	0.2	0.6	1.1	1.6
	200	0.1	0.1	0.3	0.6	0.8

### For transfer load of 4.5 kg

Positioning distance (mm)		Positioning time (sec)				
		1	10	50	100	150
Speed (mm/s)	50	0.1	0.3	1.1	2.1	3.1
	100	0.1	0.2	0.6	1.1	1.6
	200	0.1	0.2	0.4	0.6	0.9

### For transfer load of 2.5 kg

Positioning distance (mm)		Positioning time (sec)				
		1	10	50	100	150
Speed (mm/s)	50	0.1	0.3	1.1	2.1	3.1
	100	0.1	0.2	0.6	1.1	1.6
	200	0.1	0.1	0.3	0.6	0.8

Refer to page 960 for acceleration time.

- LJ1
- LG1
- LTF
- LC1
- LC7
- LC8
- LXF
- LXP
- LXS**
- LC6
- LZ
- LC3F2
- X
- D-
- E-MY

# High Rigidity Slide Table Type

## 2 Phase Stepper Motor

### With Motor Brake

# Series LXS

High Rigidity  
Direct Acting  
Guide

Ball Screw  
ø8 mm/2 mm lead

### How to Order

**LXSH2BC** - **100** **B** - **M9N** **1**

#### Stroke (mm)

Refer to the standard stroke.

#### Home position switch

Nil	None
S	Yes (Cable length 0.3 m)

#### Auto/Proximity switch type

Nil	None
-----	------

Refer to the table on the right for auto/proximity switch part numbers.

#### Number of auto/proximity switches

1	1 pc.
2	2 pcs.
⋮	⋮
6	6 pcs.

When using both auto and proximity switches, list the proximity switch part number after the auto switch part number.  
Example) M9N1G2

### Specifications

Standard stroke (mm)		50	75	100	125	150	
Performance	Body mass (kg)	2.1	2.3	2.5	2.7	2.9	
	Operating temperature range (°C)	5 to 40 (No condensation)					
	Work load (kg)	10 (4) horizontal/5 (4) vertical Note 1)					
	Speed (mm/s)	to 30 Note 2)					
	Positioning repeatability (mm)	±0.03					
Main parts	Motor	2 phase stepper motor (with brake)					
	Lead screw	Ball screw ø8 mm, 2 mm lead					
	Guide	High rigidity direct acting guide					
	Electromagnetic brake	Model	De-energized operating type				
		Static torque (N·m)	0.1 or more				
Rated voltage (V)		24 DC ±5%					
	Power consumption (W)	5					
Home position switch	Model	Photo micro sensor EE-SX673 (Refer to page 1084 for details.)					
Driver	Model	LC6D-220AD□ (Refer to page 964 for details.)					
Positioning driver	Model	LC6C-220AD (Refer to page 967 for details.)					

### Auto switch types

Symbol	Model	Wiring/Output type	Lead wire length (m)	Contact
Nil	Without auto switch			
M9N	D-M9N	3 wire/NPN	0.5	N.O. (A contact)
M9P	D-M9P	3 wire/PNP	0.5	N.O. (A contact)
M9B	D-M9B	2 wire	0.5	N.O. (A contact)
F9G	D-F9G	3 wire/NPN	0.5	N.C. (B contact)
F9H	D-F9H	3 wire/PNP	0.5	N.C. (B contact)
F9GL	D-F9GL	3 wire/NPN	3	N.C. (B contact)
F9HL	D-F9HL	3 wire/PNP	3	N.C. (B contact)
M9NL	D-M9NL	3 wire/NPN	3	N.O. (A contact)
M9PL	D-M9PL	3 wire/PNP	3	N.O. (A contact)
M9BL	D-M9BL	2 wire	3	N.O. (A contact)

### Proximity switch types

Symbol	Model	Wiring/Output type	Lead wire length (m)	Contact
GN	With sensor plate, without proximity switch	—	—	—
G	GX-F8A	3 wire/NPN	1	N.O. (A contact)
GD	GX-F8AI	3 wire/NPN	1	N.O. (A contact)
GB	GX-F8B	3 wire/NPN	1	N.C. (B contact)
GDB	GX-F8BI	3 wire/NPN	1	N.C. (B contact)
GU	GXL-8FU	2 wire/solid state	1	N.O. (A contact)
GUB	GXL-8FUB	2 wire/solid state	1	N.C. (B contact)

\* Refer to page 1082 for detailed specifications of proximity switches.



### Made to order specifications (For details, refer to page 999)

Symbol	Specifications
X20	AC servomotor specification
X60	Low particle generation specification

Note 1) When mounting a work piece to the actuator's end plate, its mass should be within the value inside ( ).

Note 2) Since vibration may increase with low speed operation, set the driver to be driven in half-step mode, and use 2 mm/s or more as a guide for speed.

### Allowable Moment (N·m)

#### Allowable static moment

Pitching	15.7
Yawing	7.84

- m : Transfer load (kg)
- L1, L2 : Overhang to work piece center of gravity (mm)
- a : Work piece acceleration (mm/sec<sup>2</sup>)
- Me : Dynamic moment

#### Allowable dynamic moment

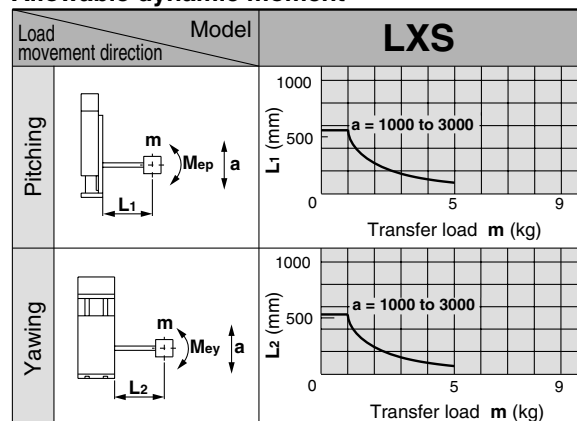

Refer to page 962 for deflection data.

# High Rigidity Slide Table Type 2 Phase Stepper Motor/With Motor Brake **Series LXS**

## Dimensions/LXSH2BC

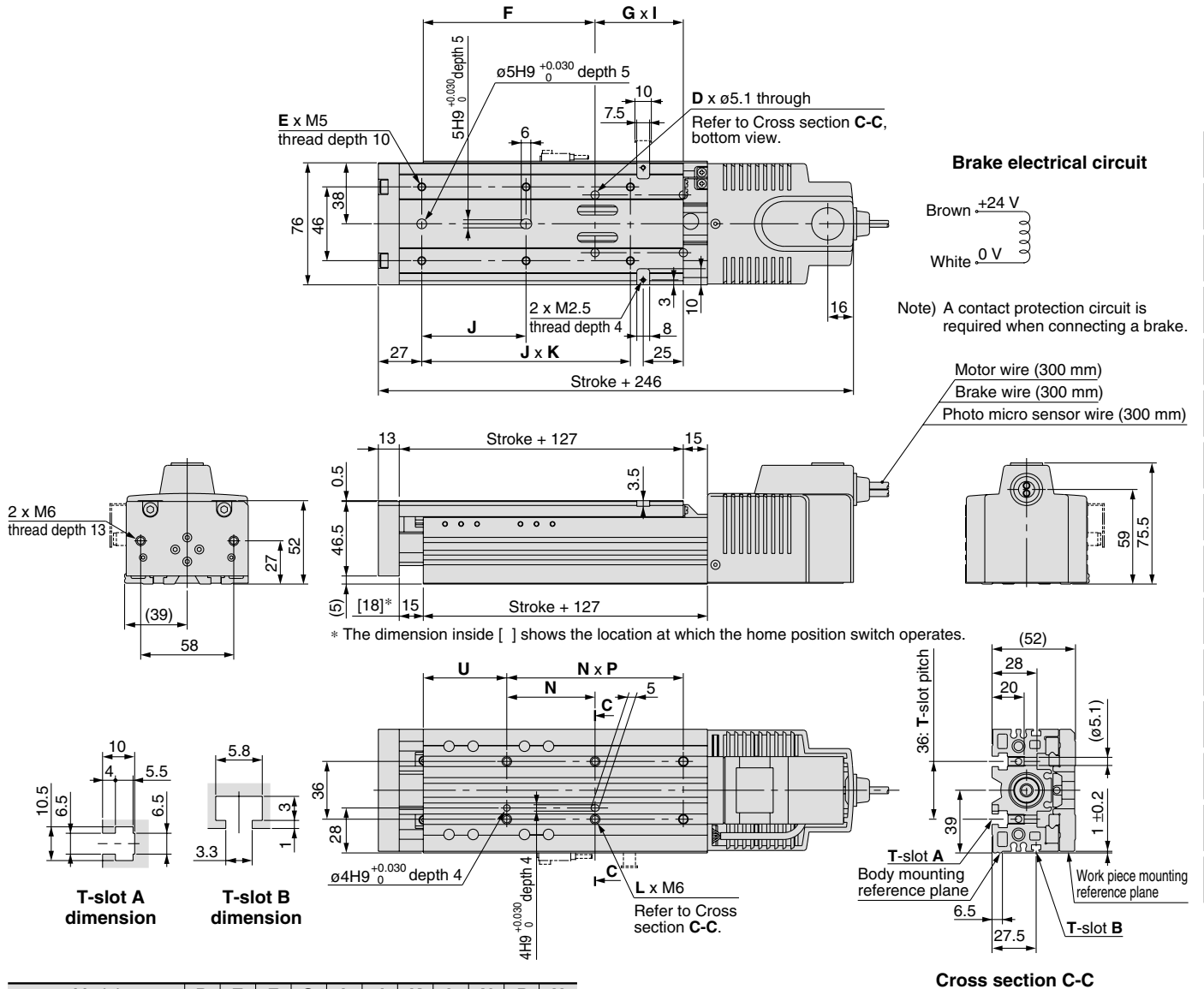

- LJ1
- LG1
- LTF
- LC1
- LC7
- LC8
- LXF
- LXP
- LXS**
- LC6□
- LZ□
- LC3F2
- X□
- D-□
- E-MY

Model	D	E	F	G	I	J	K	L	N	P	U
LXSH2BC- 50□B	4	6	107	55	1	65	2	6	55	2	52
LXSH2BC- 75□B	4	6	112	65	1	75	2	6	65	2	47
LXSH2BC-100□B	4	8	122	75	1	65	3	6	75	2	47
LXSH2BC-125□B	4	8	132	85	1	70	3	6	85	2	47
LXSH2BC-150□B	6	8	112	65	2	75	3	8	65	3	47

Refer to page 959 for mounting.

## Positioning Time Guide (for Vertical Mount)

### For transfer load of 0 kg

Positioning distance (mm)		Positioning time (sec)				
		1	10	50	100	150
Speed (mm/s)	10	0.2	1.1	5.1	10.1	15.1
	20	0.1	0.6	2.6	5.1	7.6
	30	0.1	0.4	1.7	3.4	5.1

### For transfer load of 5 kg

Positioning distance (mm)		Positioning time (sec)				
		1	10	50	100	200
Speed (mm/s)	10	0.2	1.1	5.1	10.1	15.1
	20	0.1	0.6	2.6	5.1	7.6
	30	0.1	0.4	1.7	3.4	5.1

### For transfer load of 2.5 kg

Positioning distance (mm)		Positioning time (sec)				
		1	10	50	100	150
Speed (mm/s)	10	0.2	1.1	5.1	10.1	15.1
	20	0.1	0.6	2.6	5.1	7.6
	30	0.1	0.4	1.7	3.4	5.1

Refer to page 961 for acceleration time.

# High Rigidity Slide Table Type

## 2 Phase Stepper Motor

### With Motor Brake

# Series LXS

High Rigidity  
Direct Acting  
Guide

Ball Screw  
ø8 mm/5 mm lead

### How to Order

**LXSH2BD - 100 B - M9N 1**

#### Stroke (mm)

Refer to the standard stroke.

#### Home position switch

Nil	None
S	Yes (Cable length 0.3 m)

#### Auto/Proximity switch type

Nil	None
-----	------

Refer to the table on the right for auto/proximity switch part numbers.

#### Number of auto/proximity switches

1	1 pc.
2	2 pcs.
⋮	⋮
6	6 pcs.

When using both auto and proximity switches, list the proximity switch part number after the auto switch part number.  
Example) M9N1G2

### Specifications

Standard stroke (mm)		50	75	100	125	150	
Performance	Body mass (kg)	2.1	2.3	2.5	2.7	2.9	
	Operating temperature range (°C)	5 to 40 (No condensation)					
	Work load (kg)	10 (4) horizontal/5 (4) vertical Note 1)					
	Speed (mm/s)	to 80 Note 2)					
	Positioning repeatability (mm)	±0.03					
Main parts	Motor	2 phase stepper motor (with brake)					
	Lead screw	Ball screw ø8 mm, 5 mm lead					
	Guide	High rigidity direct acting guide					
	Electromagnetic brake	Model	De-energized operating type				
		Static torque (N·m)	0.1 or more				
Rated voltage (V)		24 DC ±5%					
	Power consumption (W)	5					
Home position switch	Model	Photo micro sensor EE-SX673 (Refer to page 1084 for details.)					
Driver	Model	LC6D-220AD-□ (Refer to page 964 for details.)					
Positioning driver	Model	LC6C-220AD (Refer to page 967 for details.)					

### Auto switch types

Symbol	Model	Wiring/Output type	Lead wire length (m)	Contact
Nil	Without auto switch			
M9N	D-M9N	3 wire/NPN	0.5	N.O. (A contact)
M9P	D-M9P	3 wire/PNP	0.5	N.O. (A contact)
M9B	D-M9B	2 wire	0.5	N.O. (A contact)
F9G	D-F9G	3 wire/NPN	0.5	N.C. (B contact)
F9H	D-F9H	3 wire/PNP	0.5	N.C. (B contact)
F9GL	D-F9GL	3 wire/NPN	3	N.C. (B contact)
F9HL	D-F9HL	3 wire/PNP	3	N.C. (B contact)
M9NL	D-M9NL	3 wire/NPN	3	N.O. (A contact)
M9PL	D-M9PL	3 wire/PNP	3	N.O. (A contact)
M9BL	D-M9BL	2 wire	3	N.O. (A contact)

### Proximity switch types

Symbol	Model	Wiring/Output type	Lead wire length (m)	Contact
GN	With sensor plate, without proximity switch	—	—	—
G	GX-F8A	3 wire/NPN	1	N.O. (A contact)
GD	GX-F8AI	3 wire/NPN	1	N.O. (A contact)
GB	GX-F8B	3 wire/NPN	1	N.C. (B contact)
GDB	GX-F8BI	3 wire/NPN	1	N.C. (B contact)
GU	GXL-8FU	2 wire/solid state	1	N.O. (A contact)
GUB	GXL-8FUB	2 wire/solid state	1	N.C. (B contact)

\* Refer to page 1082 for detailed specifications of proximity switches.



**Made to order specifications**  
(For details, refer to page 999)

Symbol	Specifications
X20	AC servomotor specification
X60	Low particle generation specification

Note 1) When mounting a work piece to the actuator's end plate, its mass should be within the value inside ( ).

Note 2) Since vibration may increase with low speed operation, set the driver to be driven in half-step mode, and use 5 mm/s or more as a guide for speed.

### Allowable Moment (N·m)

#### Allowable static moment

Pitching	15.7
Yawing	7.84

m : Transfer load (kg)  
L1, L2 : Overhang to work piece center of gravity (mm)  
a : Work piece acceleration (mm/sec<sup>2</sup>)  
Me : Dynamic moment

#### Allowable dynamic moment

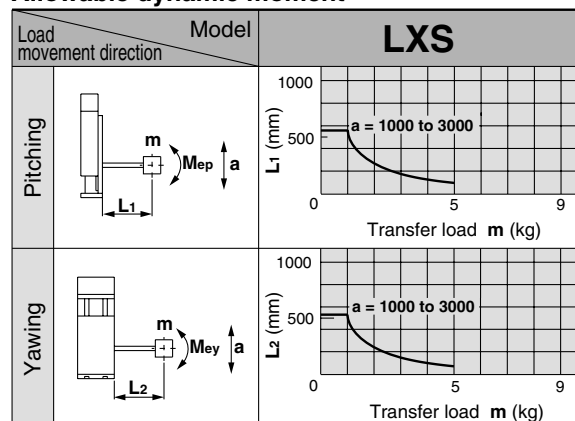

Refer to page 962 for deflection data.

# High Rigidity Slide Table Type 2 Phase Stepper Motor/With Motor Brake **Series LXS**

## Dimensions/LXSH2BD

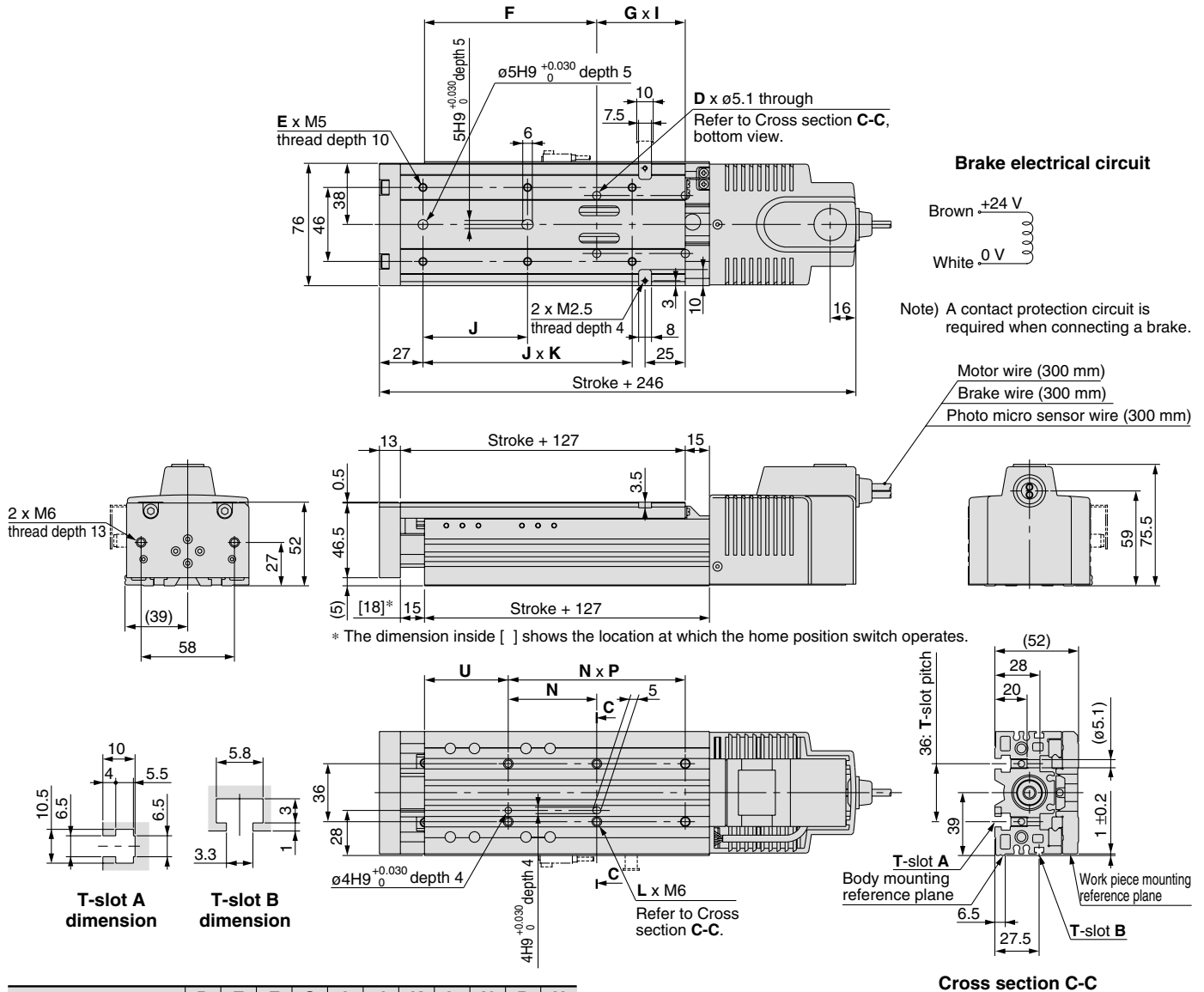

Model	D	E	F	G	I	J	K	L	N	P	U
LXSH2BD- 50□B	4	6	107	55	1	65	2	6	55	2	52
LXSH2BD- 75□B	4	6	112	65	1	75	2	6	65	2	47
LXSH2BD-100□B	4	8	122	75	1	65	3	6	75	2	47
LXSH2BD-125□B	4	8	132	85	1	70	3	6	85	2	47
LXSH2BD-150□B	6	8	112	65	2	75	3	8	65	3	47

Refer to page 959 for mounting.

## Positioning Time Guide (for Vertical Mount)

### For transfer load of 0 kg

Positioning distance (mm)		Positioning time (sec)				
		1	10	50	100	150
Speed (mm/s)	10	0.2	1.1	5.1	10.1	15.1
	40	0.1	0.3	1.3	2.6	3.8
	80	0.1	0.2	0.7	1.3	1.9

### For transfer load of 5 kg

Positioning distance (mm)		Positioning time (sec)				
		1	10	50	100	200
Speed (mm/s)	10	0.1	1	5	10	20
	40	0.1	0.3	1.3	2.6	5.1
	80	0.1	0.2	0.7	1.3	2.6

### For transfer load of 2.5 kg

Positioning distance (mm)		Positioning time (sec)				
		1	10	50	100	150
Speed (mm/s)	10	0.2	1.1	5.1	10.1	15.1
	40	0.1	0.3	1.3	2.6	3.8
	80	0.1	0.2	0.7	1.3	2.0

Refer to page 961 for acceleration time.

- LJ1
- LG1
- LTF
- LC1
- LC7
- LC8
- LXF
- LXP
- LXS**
- LC6□
- LZ□
- LC3F2
- X□
- D-□
- E-MY

# High Rigidity Slide Table Type

## 2 Phase Stepper Motor

### With Motor Brake

# Series LXS

High Rigidity  
Direct Acting  
Guide

Slide Screw  
ø8 mm/6 mm lead

### How to Order

**LXSH2SA-100 B-M9N1**

#### Stroke (mm)

Refer to the standard stroke.

#### Home position switch

Nil	None
S	Yes (Cable length 0.3 m)

#### Auto/Proximity switch type

Nil	None
-----	------

Refer to the table on the right for auto/proximity switch part numbers.

#### Number of auto/proximity switches

1	1 pc.
2	2 pcs.
⋮	⋮
6	6 pcs.

When using both auto and proximity switches, list the proximity switch part number after the auto switch part number.  
Example) M9N1G2

### Specifications

Standard stroke (mm)		50	75	100	125	150	
Performance	Body mass (kg)	2.1	2.3	2.5	2.7	2.9	
	Operating temperature range (°C)	5 to 40 (No condensation)					
	Work load (kg)	9 (4) horizontal/4 (4) vertical <small>Note 1)</small>					
	Speed (mm/s)	to 100 <small>Note 2)</small>					
	Positioning repeatability (mm)	±0.05					
Main parts	Motor	2 phase stepper motor (with brake)					
	Lead screw	Ball screw ø8 mm, 6 mm lead					
	Guide	High rigidity direct acting guide					
	Electromagnetic brake	Model	De-energized operating type				
		Static torque (N·m)	0.1 or more				
Rated voltage (V)		24 DC ±5%					
	Power consumption (W)	5					
Home position switch	Model	Photo micro sensor EE-SX673 (Refer to page 1084 for details.)					
Driver	Model	LC6D-220AD-□ (Refer to page 964 for details.)					
Positioning driver	Model	LC6C-220AD (Refer to page 967 for details.)					

#### Auto switch types

Symbol	Model	Wiring/Output type	Lead wire length (m)	Contact
Nil	Without auto switch			
M9N	D-M9N	3 wire/NPN	0.5	N.O. (A contact)
M9P	D-M9P	3 wire/PNP	0.5	N.O. (A contact)
M9B	D-M9B	2 wire	0.5	N.O. (A contact)
F9G	D-F9G	3 wire/NPN	0.5	N.C. (B contact)
F9H	D-F9H	3 wire/PNP	0.5	N.C. (B contact)
F9GL	D-F9GL	3 wire/NPN	3	N.C. (B contact)
F9HL	D-F9HL	3 wire/PNP	3	N.C. (B contact)
M9NL	D-M9NL	3 wire/NPN	3	N.O. (A contact)
M9PL	D-M9PL	3 wire/PNP	3	N.O. (A contact)
M9BL	D-M9BL	2 wire	3	N.O. (A contact)

#### Proximity switch types

Symbol	Model	Wiring/Output type	Lead wire length (m)	Contact
GN	With sensor plate, without proximity switch	—	—	—
G	GX-F8A	3 wire/NPN	1	N.O. (A contact)
GD	GX-F8AI	3 wire/NPN	1	N.O. (A contact)
GB	GX-F8B	3 wire/NPN	1	N.C. (B contact)
GDB	GX-F8BI	3 wire/NPN	1	N.C. (B contact)
GU	GXL-8FU	2 wire/solid state	1	N.O. (A contact)
GUB	GXL-8FUB	2 wire/solid state	1	N.C. (B contact)

\* Refer to page 1082 for detailed specifications of proximity switches.

Note 1) When mounting a work piece to the actuator's end plate, its mass should be within the value inside ( ).

Note 2) Since vibration may increase with low speed operation, set the driver to be driven in half-step mode, and use 6 mm/s or more as a guide for speed.

### Allowable Moment (N·m)

#### Allowable static moment

Pitching	15.7
Yawing	7.84

m : Transfer load (kg)

L1, L2 : Overhang to work piece center of gravity (mm)

a : Work piece acceleration (mm/sec<sup>2</sup>)

Me : Dynamic moment

#### Allowable dynamic moment

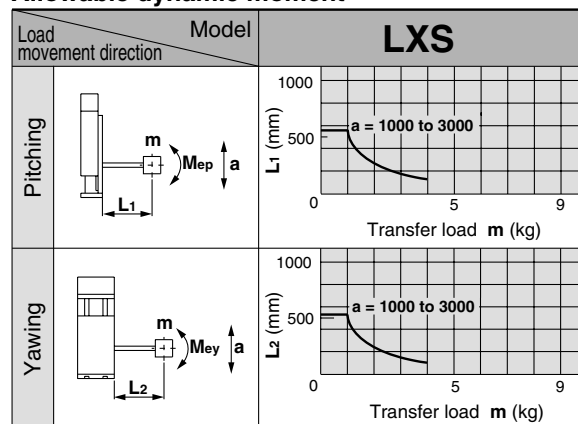

Refer to page 962 for deflection data.

# High Rigidity Slide Table Type 2 Phase Stepper Motor/With Motor Brake **Series LXS**

## Dimensions/LXSH2SA

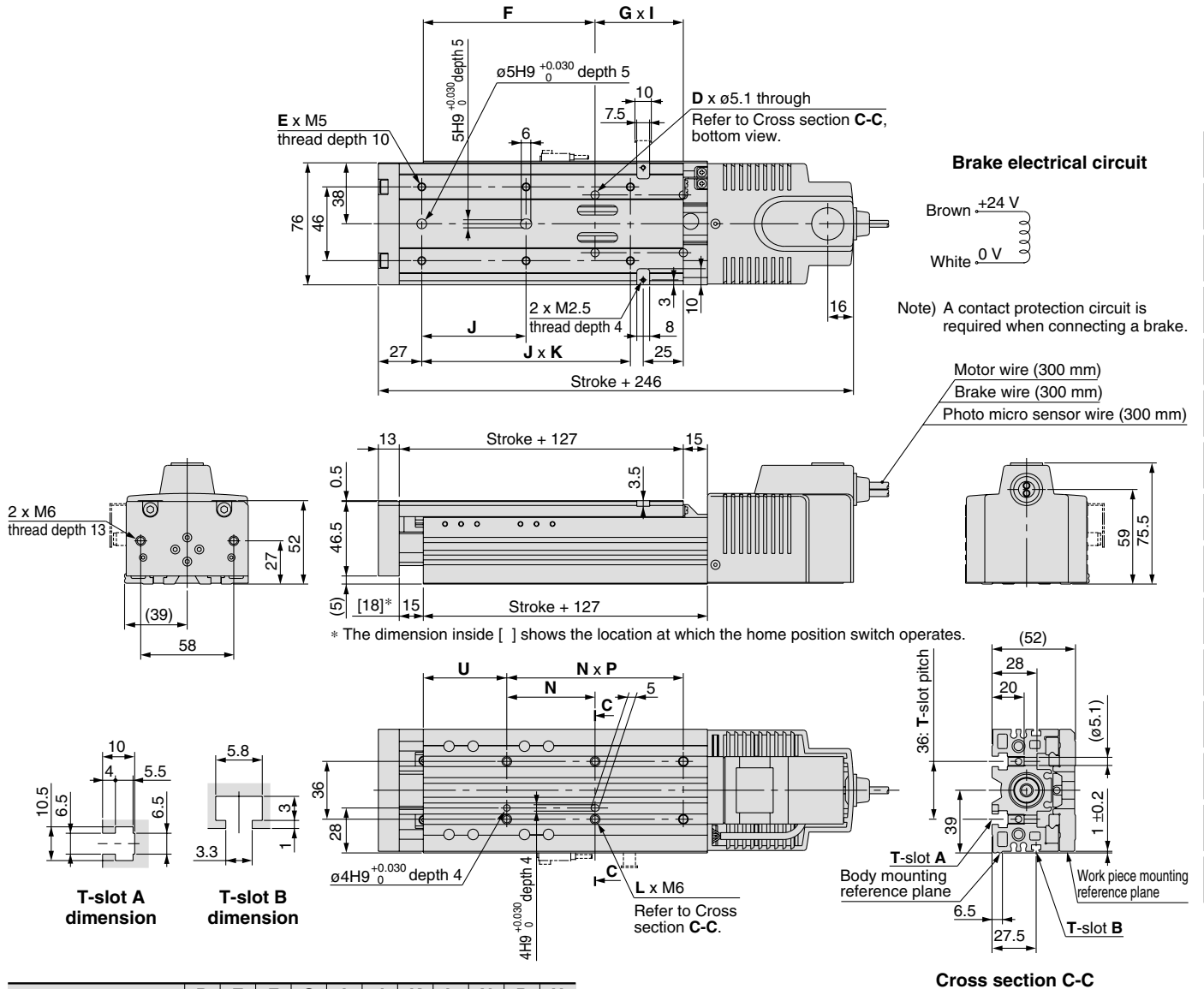

Model	D	E	F	G	I	J	K	L	N	P	U
LXSH2SA- 50□B	4	6	107	55	1	65	2	6	55	2	52
LXSH2SA- 75□B	4	6	112	65	1	75	2	6	65	2	47
LXSH2SA-100□B	4	8	122	75	1	65	3	6	75	2	47
LXSH2SA-125□B	4	8	132	85	1	70	3	6	85	2	47
LXSH2SA-150□B	6	8	112	65	2	75	3	8	65	3	47

Refer to page 959 for mounting.

## Positioning Time Guide (for Vertical Mount)

### For transfer load of 0 kg

Positioning distance (mm)		Positioning time (sec)				
		1	10	50	100	150
Speed (mm/s)	10	0.2	1.1	5.1	10.1	15.1
	50	0.1	0.3	1.1	2.1	3.1
	100	0.1	0.2	0.6	1.1	1.6

### For transfer load of 4 kg

Positioning distance (mm)		Positioning time (sec)				
		1	10	50	100	150
Speed (mm/s)	10	0.2	1.1	5.1	10.1	15.1
	50	0.1	0.3	1.1	2.1	3.1
	100	0.1	0.2	0.6	1.1	1.6

### For transfer load of 2 kg

Positioning distance (mm)		Positioning time (sec)				
		1	10	50	100	150
Speed (mm/s)	10	0.2	1.1	5.1	10.1	15.1
	50	0.1	0.3	1.1	2.1	3.1
	100	0.1	0.2	0.6	1.1	1.6

Refer to page 960 for acceleration time.

- LJ1
- LG1
- LTF
- LC1
- LC7
- LC8
- LXF
- LXP
- LXS**
- LC6□
- LZ□
- LC3F2
- X□
- D-□
- E-MY

# High Rigidity Slide Table Type

## 2 Phase Stepper Motor

### With Motor Brake

# Series LXS

High Rigidity  
Direct Acting  
Guide

Slide Screw  
Ø8 mm/12 mm lead

### How to Order

**LXSH2SB - 100 B - M9N 1**

#### Stroke (mm)

Refer to the standard stroke.

#### Home position switch

Nil	None
S	Yes (Cable length 0.3m)

#### Auto/Proximity switch type

Nil	None
-----	------

Refer to the table on the right for auto/proximity switch part numbers.

#### Number of auto/proximity switches

1	1 pc.
2	2 pcs.
⋮	⋮
6	6 pcs.

When using both auto and proximity switches, list the proximity switch part number after the auto switch part number.  
Example) M9N1G2

### Specifications

Standard stroke (mm)		50	75	100	125	150	
Performance	Body mass (kg)	2.1	2.3	2.5	2.7	2.9	
	Operating temperature range (°C)	5 to 40 (No condensation)					
	Work load (kg)	4.5 (4) horizontal/2 (2) vertical <sup>Note 1)</sup>					
	Speed (mm/s)	to 200 <sup>Note 2)</sup>					
	Positioning repeatability (mm)	±0.05					
Main parts	Motor	2 phase stepper motor (with brake)					
	Lead screw	Ball screw ø8 mm, 12 mm lead					
	Guide	High rigidity direct acting guide					
	Electromagnetic brake	Model	De-energized operating type				
		Static torque (N·m)	0.1 or more				
Rated voltage (V)		24 DC ±5%					
	Power consumption (W)	5					
Home position switch	Model	Photo micro sensor EE-SX673 (Refer to page 1084 for details.)					
Driver	Model	LC6D-220AD-□ (Refer to page 964 for details.)					
Positioning driver	Model	LC6C-220AD (Refer to page 967 for details.)					

#### Auto switch types

Symbol	Model	Wiring/Output type	Lead wire length (m)	Contact
Nil	Without auto switch			
M9N	D-M9N	3 wire/NPN	0.5	N.O. (A contact)
M9P	D-M9P	3 wire/PNP	0.5	N.O. (A contact)
M9B	D-M9B	2 wire	0.5	N.O. (A contact)
F9G	D-F9G	3 wire/NPN	0.5	N.C. (B contact)
F9H	D-F9H	3 wire/PNP	0.5	N.C. (B contact)
F9GL	D-F9GL	3 wire/NPN	3	N.C. (B contact)
F9HL	D-F9HL	3 wire/PNP	3	N.C. (B contact)
M9NL	D-M9NL	3 wire/NPN	3	N.O. (A contact)
M9PL	D-M9PL	3 wire/PNP	3	N.O. (A contact)
M9BL	D-M9BL	2 wire	3	N.O. (A contact)

#### Proximity switch types

Symbol	Model	Wiring/Output type	Lead wire length (m)	Contact
GN	With sensor plate, without proximity switch	—	—	—
G	GX-F8A	3 wire/NPN	1	N.O. (A contact)
GD	GX-F8AI	3 wire/NPN	1	N.O. (A contact)
GB	GX-F8B	3 wire/NPN	1	N.C. (B contact)
GDB	GX-F8BI	3 wire/NPN	1	N.C. (B contact)
GU	GXL-8FU	2 wire/solid state	1	N.O. (A contact)
GUB	GXL-8FUB	2 wire/solid state	1	N.C. (B contact)

\* Refer to page 1082 for detailed specifications of proximity switches.

Note 1) When mounting a work piece to the actuator's end plate, its mass should be within the value inside ( ).

Note 2) Since vibration may increase with low speed operation, set the driver to be driven in half-step mode, and use 12 mm/s or more as a guide for speed.

### Allowable Moment (N·m)

#### Allowable static moment

Pitching	15.7
Yawing	7.84

m : Transfer load (kg)

L1, L2 : Overhang to work piece center of gravity (mm)

a : Work piece acceleration (mm/sec<sup>2</sup>)

Me : Dynamic moment

#### Allowable dynamic moment

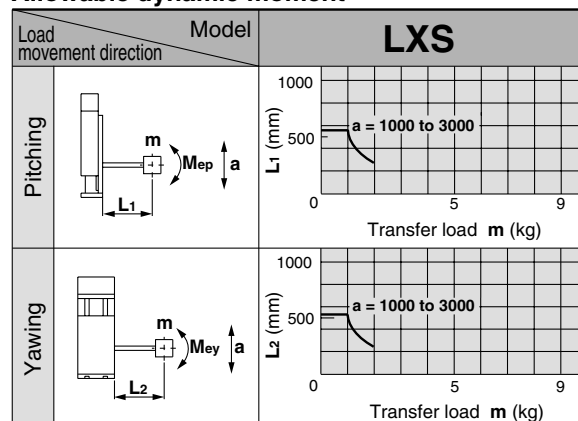

Refer to page 962 for deflection data.



# High Rigidity Slide Table Type 2 Phase Stepper Motor/With Motor Brake **Series LXS**

## Dimensions/LXSH2SB

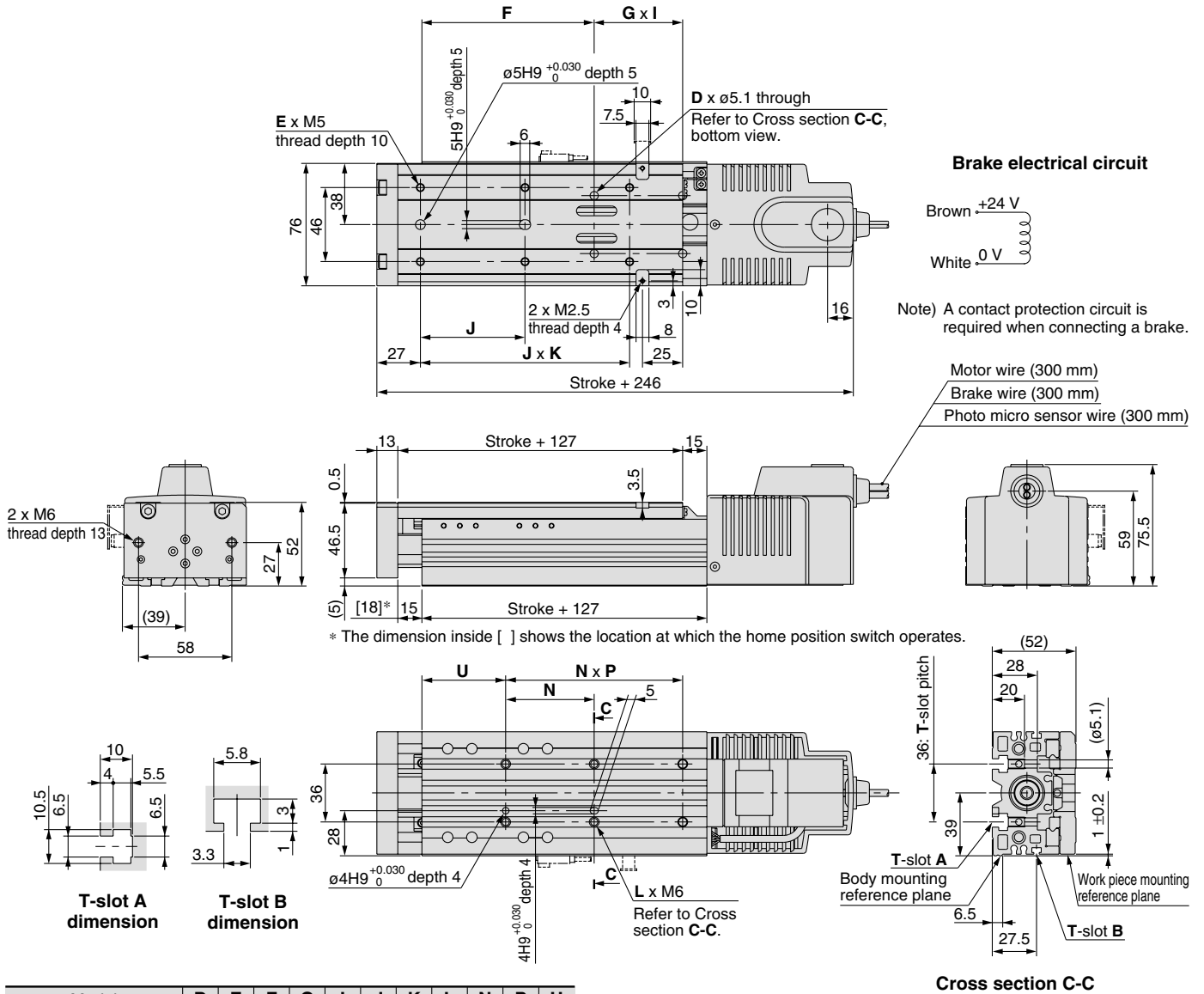

- LJ1
- LG1
- LTF
- LC1
- LC7
- LC8
- LXF
- LXP
- LXS**
- LC6□
- LZ□
- LC3F2
- X□
- D-□
- E-MY

Model	D	E	F	G	I	J	K	L	N	P	U
LXSH2SB- 50□B	4	6	107	55	1	65	2	6	55	2	52
LXSH2SB- 75□B	4	6	112	65	1	75	2	6	65	2	47
LXSH2SB-100□B	4	8	122	75	1	65	3	6	75	2	47
LXSH2SB-125□B	4	8	132	85	1	70	3	6	85	2	47
LXSH2SB-150□B	6	8	112	65	2	75	3	8	65	3	47

Refer to page 959 for mounting.

### Positioning Time Guide (for Vertical Mount)

For transfer load of 0 kg

Positioning distance (mm)		Positioning time (sec)				
		1	10	50	100	150
Speed (mm/s)	50	0.1	0.3	1.1	2.1	4.1
	100	0.1	0.2	0.6	1.1	2.1
	200	0.1	0.1	0.3	0.6	1.1

For transfer load of 2 kg

Positioning distance (mm)		Positioning time (sec)				
		1	10	50	100	150
Speed (mm/s)	50	0.1	0.3	1.1	2.1	4.1
	100	0.1	0.2	0.6	1.1	2.1
	200	0.1	0.2	0.4	0.6	1.1

For transfer load of 1 kg

Positioning distance (mm)		Positioning time (sec)				
		1	10	50	100	150
Speed (mm/s)	50	0.1	0.3	1.1	2.1	4.1
	100	0.1	0.2	0.6	1.1	2.1
	200	0.1	0.1	0.3	0.6	1.1

Refer to page 960 for acceleration time.

# High Rigidity Slide Table Type

## 5 Phase Stepper Motor Without Motor Brake

High Rigidity  
Direct Acting  
Guide

Ball Screw  
ø8 mm/2 mm lead

# Series LXS

### How to Order

LXSH5 **BC** - **100** - **M9N** **1**

#### Stroke (mm)

Refer to the standard stroke.

#### Home position switch

Nil	None
S	Yes (Cable length 0.3 m)

#### Auto/Proximity switch type

Nil	None
-----	------

Refer to the table on the right for auto/proximity switch part numbers.

#### Number of auto/proximity switches

1	1 pc.
2	2 pcs.
⋮	⋮
6	6 pcs.

When using both auto and proximity switches, list the proximity switch part number after the auto switch part number. Example) M9N1G2

### Specifications

Standard stroke (mm)		50	75	100	125	150
Performance	Body mass (kg)	1.9	2.1	2.3	2.5	2.7
	Operating temperature range (°C)	5 to 40 (No condensation)				
	Work load (kg)	10 (4) horizontal/5 (4) vertical (Note 1)				
	Speed (mm/s)	to 30 (Note 2)				
	Positioning repeatability (mm)	±0.03				
Main parts	Motor	5 phase stepper motor (without brake)				
	Lead screw	Ball screw ø8 mm, 2 mm lead				
	Guide	High rigidity direct acting guide				
Home position switch	Model	Photo micro sensor EE-SX673 (Refer to page 1084 for details.)				
Driver	Model	LC6D-507AD-□ (Refer to page 964 for details.)				

Note 1) When mounting a work piece to the actuator's end plate, its mass should be within the value inside ( ).

Note 2) Since vibration may increase with low speed operation, set the driver to be driven in half-step mode, and use 2 mm/s or more as a guide for speed.

### Allowable Moment (N·m)

#### Allowable static moment

Pitching	15.7
Rolling	15.7
Yawing	7.84

**m** : Transfer load (kg)  
**L1, L2** : Overhang to work piece center of gravity (mm)  
**a** : Work piece acceleration (mm/sec<sup>2</sup>)  
**Me** : Dynamic moment

#### Allowable dynamic moment

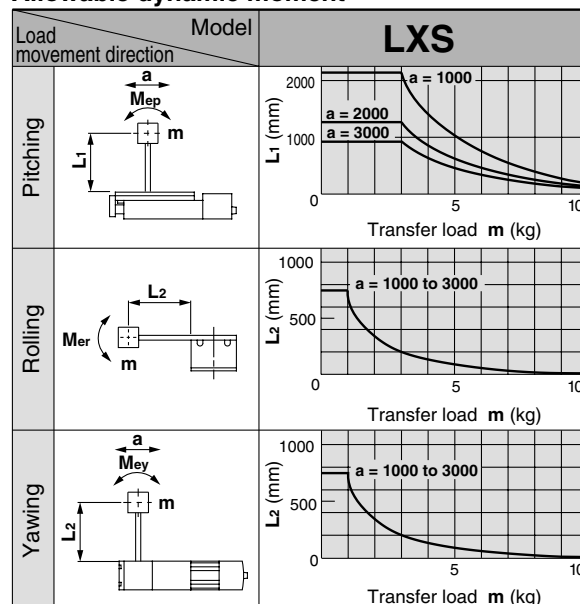

Refer to page 962 for deflection data.

#### Auto switch types

Symbol	Model	Wiring/Output type	Lead wire length (m)	Contact
Nil	Without auto switch			
M9N	D-M9N	3 wire/NPN	0.5	N.O. (A contact)
M9P	D-M9P	3 wire/PNP	0.5	N.O. (A contact)
M9B	D-M9B	2 wire	0.5	N.O. (A contact)
F9G	D-F9G	3 wire/NPN	0.5	N.C. (B contact)
F9H	D-F9H	3 wire/PNP	0.5	N.C. (B contact)
F9GL	D-F9GL	3 wire/NPN	3	N.C. (B contact)
F9HL	D-F9HL	3 wire/PNP	3	N.C. (B contact)
M9NL	D-M9NL	3 wire/NPN	3	N.O. (A contact)
M9PL	D-M9PL	3 wire/PNP	3	N.O. (A contact)
M9BL	D-M9BL	2 wire	3	N.O. (A contact)

#### Proximity switch types

Symbol	Model	Wiring/Output type	Lead wire length (m)	Contact
GN	With sensor plate, without proximity switch	—	—	—
G	GX-F8A	3 wire/NPN	1	N.O. (A contact)
GD	GX-F8AI	3 wire/NPN	1	N.O. (A contact)
GB	GX-F8B	3 wire/NPN	1	N.C. (B contact)
GDB	GX-F8BI	3 wire/NPN	1	N.C. (B contact)
GU	GXL-8FU	2 wire/Solid state	1	N.O. (A contact)
GUB	GXL-8FUB	2 wire/Solid state	1	N.C. (B contact)

\* Refer to page 1082 for detailed specifications of proximity switches.



Made to order specifications  
(For details, refer to page 999)

Symbol	Specifications
X20	AC servomotor specification
X60	Low particle generation specification

# High Rigidity Slide Table Type 5 Phase Stepper Motor/Without Motor Brake **Series LXS**

## Dimensions/LXSH5BC

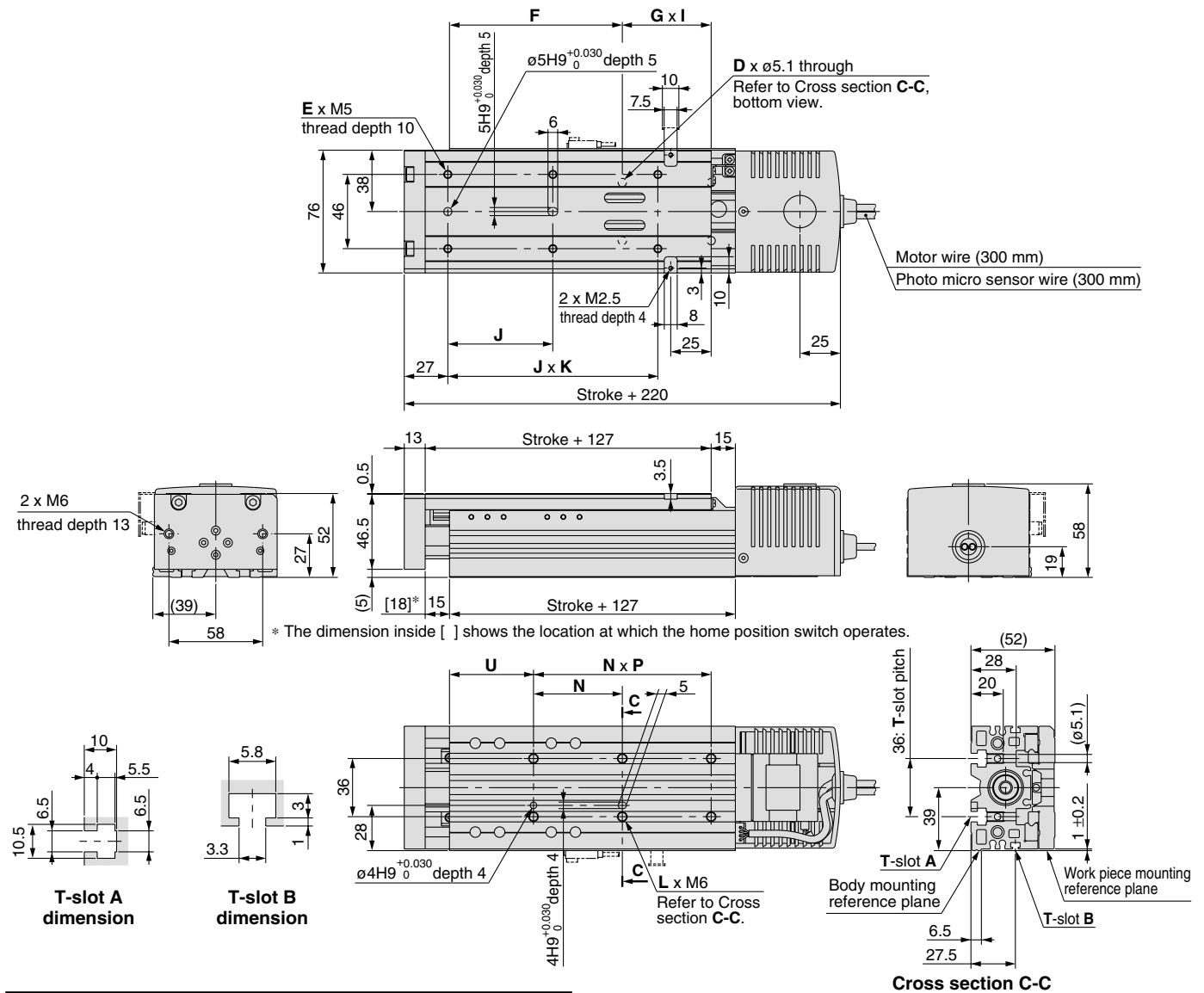

Model	D	E	F	G	I	J	K	L	N	P	U
LXSH5BC- 50	4	6	107	55	1	65	2	6	55	2	52
LXSH5BC- 75	4	6	112	65	1	75	2	6	65	2	47
LXSH5BC-100	4	8	122	75	1	65	3	6	75	2	47
LXSH5BC-125	4	8	132	85	1	70	3	6	85	2	47
LXSH5BC-150	6	8	112	65	2	75	3	8	65	3	47

Refer to page 959 for mounting.

## Positioning Time Guide (for Horizontal Mount)

### For transfer load of 0 kg

Positioning distance (mm)		Positioning time (sec)				
		1	10	50	100	150
Speed (mm/s)	10	0.2	1.1	5.1	10.1	15.1
	20	0.1	0.6	2.6	5.1	7.6
	30	0.1	0.4	1.7	3.4	5.1

### For transfer load of 10 kg

Positioning distance (mm)		Positioning time (sec)				
		1	10	50	100	150
Speed (mm/s)	10	0.2	1.1	5.1	10.1	15.1
	20	0.1	0.6	2.6	5.1	7.6
	30	0.1	0.4	1.7	3.4	5.1

### For transfer load of 5 kg

Positioning distance (mm)		Positioning time (sec)				
		1	10	50	100	150
Speed (mm/s)	10	0.2	1.1	5.1	10.1	15.1
	20	0.1	0.6	2.6	5.1	7.6
	30	0.1	0.4	1.7	3.4	5.1

Refer to page 961 for acceleration time.

- LJ1
- LG1
- LTF
- LC1
- LC7
- LC8
- LXF
- LXP
- LXS**
- LC6
- LZ
- LC3F2
- X
- D-
- E-MY

# High Rigidity Slide Table Type

## 5 Phase Stepper Motor Without Motor Brake

High Rigidity  
Direct Acting  
Guide

Ball Screw  
Ø8 mm/5 mm lead

# Series LXS

### How to Order

**LXSH5** **BD** - **100** - **M9N** **1**

• **Stroke (mm)**  
Refer to the standard stroke.

**Home position switch**

Nil	None
S	Yes (Cable length 0.3 m)

**Auto/Proximity switch type**

Nil	None
-----	------

Refer to the table on the right for auto/proximity switch part numbers.

• **Number of auto/proximity switches**

1	1 pc.
2	2 pcs.
⋮	⋮
6	6 pcs.

When using both auto and proximity switches, list the proximity switch part number after the auto switch part number. Example) M9N1G2

### Specifications

Standard stroke (mm)		50	75	100	125	150
Performance	Body mass (kg)	1.9	2.1	2.3	2.5	2.7
	Operating temperature range (°C)	5 to 40 (No condensation)				
	Work load (kg)	10 (4) horizontal/5 (4) vertical Note 1)				
	Speed (mm/s)	to 80 Note 2)				
	Positioning repeatability (mm)	±0.03				
Main parts	Motor	5 phase stepper motor (without brake)				
	Lead screw	Ball screw ø8 mm, 5 mm lead				
	Guide	High rigidity direct acting guide				
Home position switch	Model	Photo micro sensor EE-SX673 (Refer to page 1084 for details.)				
Driver	Model	LC6D-507AD-□ (Refer to page 964 for details.)				

Note 1) When mounting a work piece to the actuator's end plate, its mass should be within the value inside ( ).

Note 2) Since vibration may increase with low speed operation, set the driver to be driven in half-step mode, and use 5 mm/s or more as a guide for speed.

### Allowable Moment (N·m)

#### Allowable static moment

Pitching	15.7
Rolling	15.7
Yawing	7.84

**m** : Transfer load (kg)  
**L1, L2** : Overhang to work piece center of gravity (mm)  
**a** : Work piece acceleration (mm/sec<sup>2</sup>)  
**Me** : Dynamic moment

#### Allowable dynamic moment

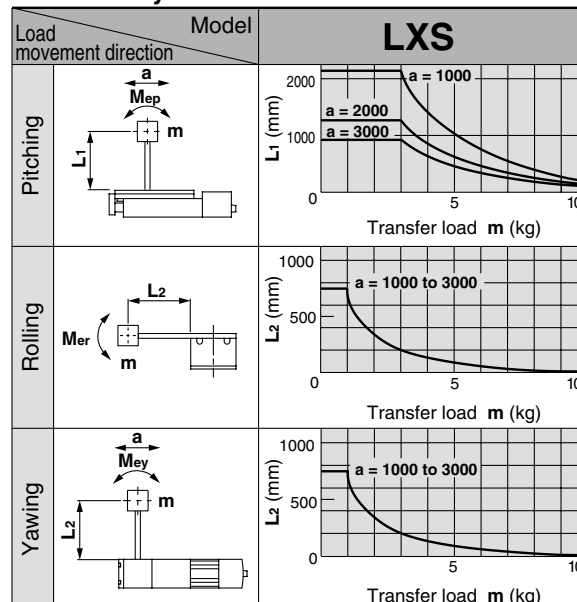

Refer to page 962 for deflection data.

### Auto switch types

Symbol	Model	Wiring/Output type	Lead wire length (m)	Contact
Nil	Without auto switch			
M9N	D-M9N	3 wire/NPN	0.5	N.O. (A contact)
M9P	D-M9P	3 wire/PNP	0.5	N.O. (A contact)
M9B	D-M9B	2 wire	0.5	N.O. (A contact)
F9G	D-F9G	3 wire/NPN	0.5	N.C. (B contact)
F9H	D-F9H	3 wire/PNP	0.5	N.C. (B contact)
F9GL	D-F9GL	3 wire/NPN	3	N.C. (B contact)
F9HL	D-F9HL	3 wire/PNP	3	N.C. (B contact)
M9NL	D-M9NL	3 wire/NPN	3	N.O. (A contact)
M9PL	D-M9PL	3 wire/PNP	3	N.O. (A contact)
M9BL	D-M9BL	2 wire	3	N.O. (A contact)

### Proximity switch types

Symbol	Model	Wiring/Output type	Lead wire length (m)	Contact
GN	With sensor plate, without proximity switch	—	—	—
G	GX-F8A	3 wire/NPN	1	N.O. (A contact)
GD	GX-F8AI	3 wire/NPN	1	N.O. (A contact)
GB	GX-F8B	3 wire/NPN	1	N.C. (B contact)
GDB	GX-F8BI	3 wire/NPN	1	N.C. (B contact)
GU	GXL-8FU	2 wire/Solid state	1	N.O. (A contact)
GUB	GXL-8FUB	2 wire/Solid state	1	N.C. (B contact)

\* Refer to page 1082 for detailed specifications of proximity switches.



**Made to order specifications**  
(For details, refer to page 999)

Symbol	Specifications
X20	AC servomotor specification
X60	Low particle generation specification

# High Rigidity Slide Table Type 5 Phase Stepper Motor/Without Motor Brake **Series LXS**

## Dimensions/LXSH5BD

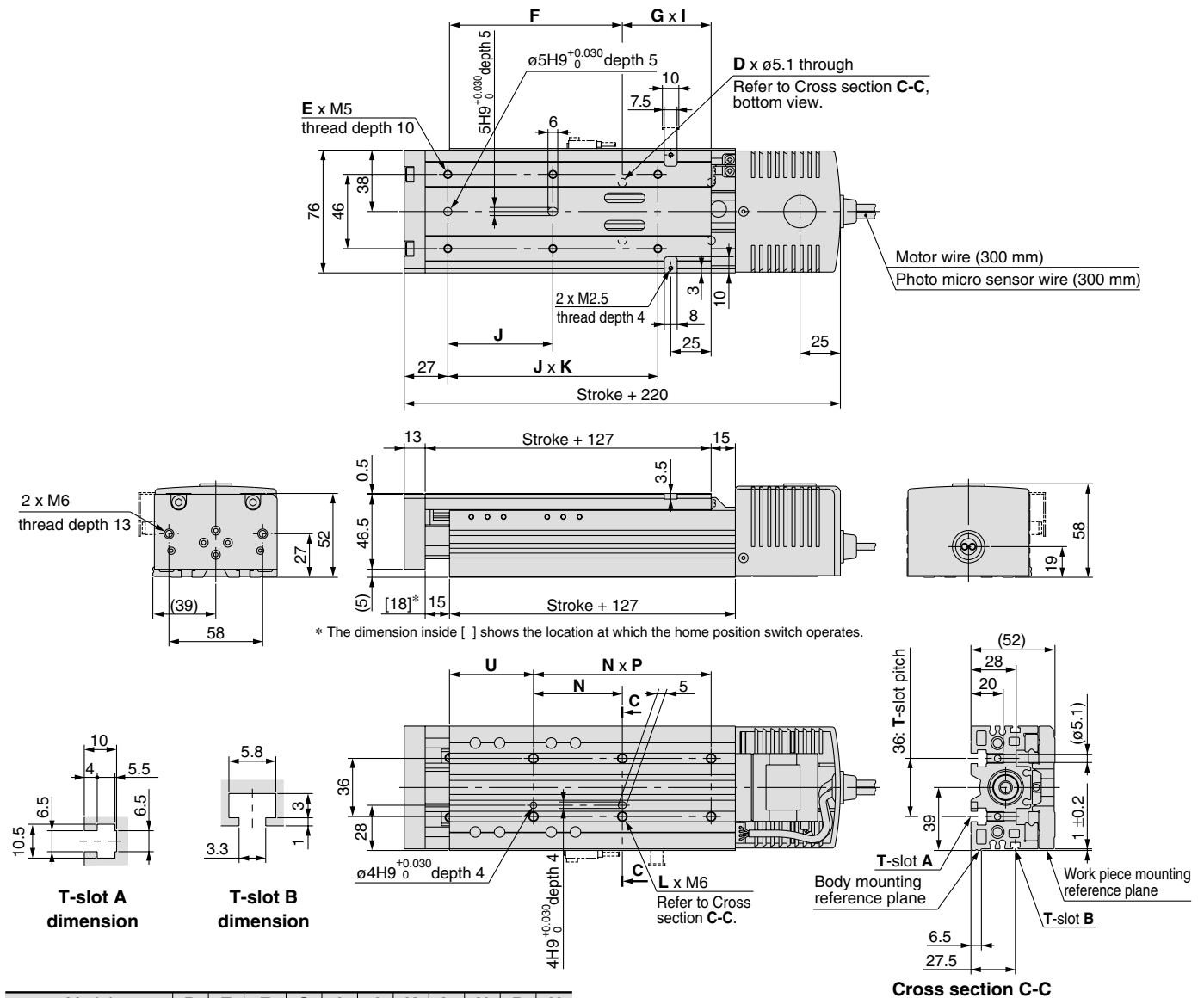

Model	D	E	F	G	I	J	K	L	N	P	U
LXSH5BD- 50	4	6	107	55	1	65	2	6	55	2	52
LXSH5BD- 75	4	6	112	65	1	75	2	6	65	2	47
LXSH5BD-100	4	8	122	75	1	65	3	6	75	2	47
LXSH5BD-125	4	8	132	85	1	70	3	6	85	2	47
LXSH5BD-150	6	8	112	65	2	75	3	8	65	3	47

Refer to page 959 for mounting.

## Positioning Time Guide (for Horizontal Mount)

### For transfer load of 0 kg

		Positioning time (sec)				
		1	10	50	100	150
Speed (mm/s)	10	0.2	1.1	5.1	10.1	15.1
	40	0.1	0.3	1.3	2.6	3.8
	80	0.1	0.2	0.7	1.3	1.9

### For transfer load of 10 kg

		Positioning time (sec)				
		1	10	50	100	150
Speed (mm/s)	10	0.2	1.1	5.1	10.1	15.1
	40	0.1	0.3	1.3	2.6	3.8
	80	0.1	0.2	0.7	1.3	2.0

### For transfer load of 5 kg

		Positioning time (sec)				
		1	10	50	100	150
Speed (mm/s)	10	0.2	1.1	5.1	10.1	15.1
	40	0.1	0.3	1.3	2.6	3.8
	80	0.1	0.2	0.7	1.3	2.0

Refer to page 961 for acceleration time.

- LJ1
- LG1
- LTF
- LC1
- LC7
- LC8
- LXF
- LXP
- LXS**
- LC6
- LZ
- LC3F2
- X
- D-
- E-MY

# High Rigidity Slide Table Type

## 5 Phase Stepper Motor Without Motor Brake

High Rigidity  
Direct Acting  
Guide

Slide Screw  
Ø8 mm/6 mm lead

# Series LXS

### How to Order

LXSH5 SA - 100 - M9N 1

Stroke (mm)  
Refer to the standard stroke.

Home position switch

Nil	None
S	Yes (Cable length 0.3 m)

Number of auto/proximity switches

1	1 pc.
2	2 pcs.
⋮	⋮
6	6 pcs.

Auto/Proximity switch type

Nil	None
-----	------

When using both auto and proximity switches, list the proximity switch part number after the auto switch part number.  
Example) M9N1G2

### Specifications

Standard stroke (mm)		50	75	100	125	150
Performance	Body mass (kg)	1.9	2.1	2.3	2.5	2.7
	Operating temperature range (°C)	5 to 40 (No condensation)				
	Work load (kg)	6 (4) horizontal/2 (2) vertical <sup>Note 1)</sup>				
	Speed (mm/s)	to 100 <sup>Note 2)</sup>				
	Positioning repeatability (mm)	±0.05				
Main parts	Motor	5 phase stepper motor (without brake)				
	Lead screw	Slide screw Ø8 mm, 6 mm lead				
	Guide	High rigidity direct acting guide				
Home position switch	Model	Photo micro sensor EE-SX673 (Refer to page 1084 for details.)				
Driver	Model	LC6D-507AD-□ (Refer to page 964 for details.)				

### Auto switch types

Symbol	Model	Wiring/Output type	Lead wire length (m)	Contact
Nil	Without auto switch			
M9N	D-M9N	3 wire/NPN	0.5	N.O. (A contact)
M9P	D-M9P	3 wire/PNP	0.5	N.O. (A contact)
M9B	D-M9B	2 wire	0.5	N.O. (A contact)
F9G	D-F9G	3 wire/NPN	0.5	N.C. (B contact)
F9H	D-F9H	3 wire/PNP	0.5	N.C. (B contact)
F9GL	D-F9GL	3 wire/NPN	3	N.C. (B contact)
F9HL	D-F9HL	3 wire/PNP	3	N.C. (B contact)
M9NL	D-M9NL	3 wire/NPN	3	N.O. (A contact)
M9PL	D-M9PL	3 wire/PNP	3	N.O. (A contact)
M9BL	D-M9BL	2 wire	3	N.O. (A contact)

### Proximity switch types

Symbol	Model	Wiring/Output type	Lead wire length (m)	Contact
GN	With sensor plate, without proximity switch	—	—	—
G	GX-F8A	3 wire/NPN	1	N.O. (A contact)
GD	GX-F8AI	3 wire/NPN	1	N.O. (A contact)
GB	GX-F8B	3 wire/NPN	1	N.C. (B contact)
GDB	GX-F8BI	3 wire/NPN	1	N.C. (B contact)
GU	GXL-8FU	2 wire/solid state	1	N.O. (A contact)
GUB	GXL-8FUB	2 wire/solid state	1	N.C. (B contact)

\* Refer to page 1082 for detailed specifications of proximity switches.

Note 1) When mounting a work piece to the actuator's end plate, its mass should be within the value inside ( ).

Note 2) Since vibration may increase with low speed operation, set the driver to be driven in half-step mode, and use 6 mm/s or more as a guide for speed.

### Allowable Moment (N·m)

#### Allowable static moment

Pitching	15.7
Rolling	15.7
Yawing	7.84

m : Transfer load (kg)  
L<sub>1</sub>, L<sub>2</sub> : Overhang to work piece center of gravity (mm)  
a : Work piece acceleration (mm/sec<sup>2</sup>)  
Me : Dynamic moment

#### Allowable dynamic moment

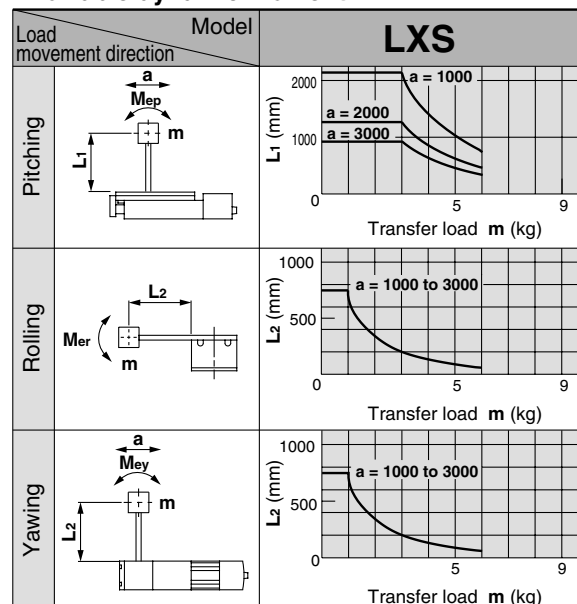

Refer to page 962 for deflection data.

# High Rigidity Slide Table Type 5 Phase Stepper Motor/Without Motor Brake **Series LXS**

## Dimensions/LXSH5SA

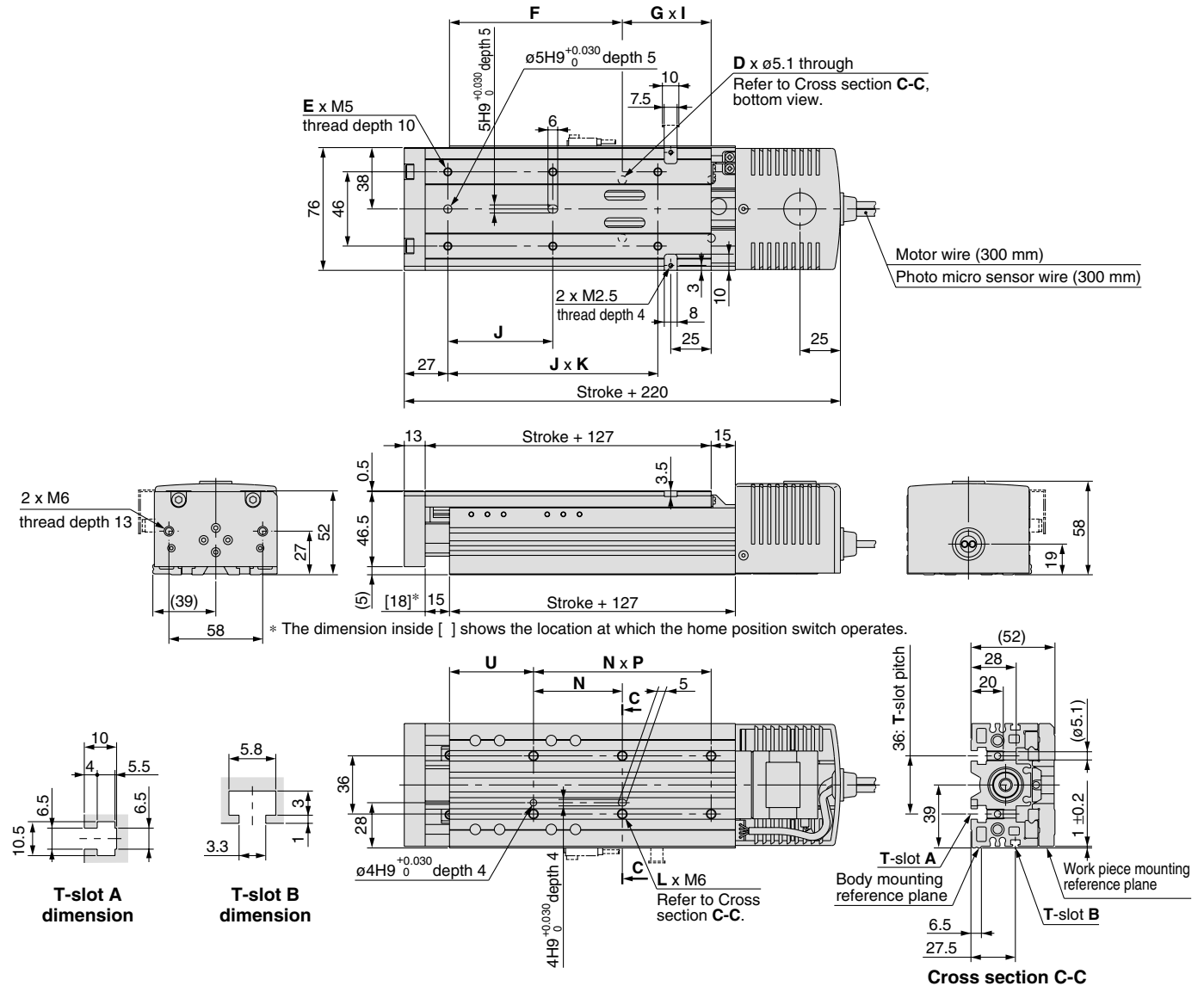

Model	D	E	F	G	I	J	K	L	N	P	U
LXSH5SA- 50	4	6	107	55	1	65	2	6	55	2	52
LXSH5SA- 75	4	6	112	65	1	75	2	6	65	2	47
LXSH5SA-100	4	8	122	75	1	65	3	6	75	2	47
LXSH5SA-125	4	8	132	85	1	70	3	6	85	2	47
LXSH5SA-150	6	8	112	65	2	75	3	8	65	3	47

Refer to page 959 for mounting.

## Positioning Time Guide (for Horizontal Mount)

### For transfer load of 0 kg

		Positioning time (sec)				
		1	10	50	100	150
Speed (mm/s)	10	0.2	1.1	5.1	10.1	15.1
	50	0.1	0.3	1.1	2.1	3.1
	100	0.1	0.2	0.6	1.1	1.6

### For transfer load of 6 kg

		Positioning time (sec)				
		1	10	50	100	150
Speed (mm/s)	10	0.2	1.1	5.1	10.1	15.1
	50	0.1	0.3	1.1	2.1	3.1
	100	0.1	0.2	0.6	1.1	1.6

### For transfer load of 3 kg

		Positioning time (sec)				
		1	10	50	100	150
Speed (mm/s)	10	0.2	1.1	5.1	10.1	15.1
	50	0.1	0.3	1.1	2.1	3.1
	100	0.1	0.2	0.6	1.1	1.6

Refer to page 960 for acceleration time.

- LJ1
- LG1
- LTF
- LC1
- LC7
- LC8
- LXF
- LXP
- LXS**
- LC6
- LZ
- LC3F2
- X
- D-
- E-MY

# High Rigidity Slide Table Type

## 5 Phase Stepper Motor Without Motor Brake

High Rigidity  
Direct Acting  
Guide

Slide Screw  
Ø8 mm/12 mm lead

# Series LXS

### How to Order

**LXSH5 SB - 100 - M9N 1**

#### Stroke (mm)

Refer to the standard stroke.

#### Home position switch

Nil	None
S	Yes (Cable length 0.3 m)

#### Auto/Proximity switch type

Nil	None
-----	------

Refer to the table on the right for auto/proximity switch part numbers.

#### Number of auto/proximity switches

1	1 pc.
2	2 pcs.
⋮	⋮
6	6 pcs.

When using both auto and proximity switches, list the proximity switch part number after the auto switch part number.  
Example) M9N1G2

### Specifications

Standard stroke (mm)		50	75	100	125	150
Performance	Body mass (kg)	1.9	2.1	2.3	2.5	2.7
	Operating temperature range (°C)	5 to 40 (No condensation)				
	Work load (kg)	3 (3) horizontal/1 (1) vertical				
	Speed (mm/s)	to 200 (Note 1)				
	Positioning repeatability (mm)	±0.05				
Main parts	Motor	5 phase stepper motor (without brake)				
	Lead screw	Slide screw ø8 mm, 12 mm lead				
	Guide	High rigidity direct acting guide				
Home position switch	Model	Photo micro sensor EE-SX673 (Refer to page 1084 for details.)				
Driver	Model	LC6D-507AD-□ (Refer to page 964 for details.)				

### Auto switch types

Symbol	Model	Wiring/Output type	Lead wire length (m)	Contact
Nil	Without auto switch			
M9N	D-M9N	3 wire/NPN	0.5	N.O. (A contact)
M9P	D-M9P	3 wire/PNP	0.5	N.O. (A contact)
M9B	D-M9B	2 wire	0.5	N.O. (A contact)
F9G	D-F9G	3 wire/NPN	0.5	N.C. (B contact)
F9H	D-F9H	3 wire/PNP	0.5	N.C. (B contact)
F9GL	D-F9GL	3 wire/NPN	3	N.C. (B contact)
F9HL	D-F9HL	3 wire/PNP	3	N.C. (B contact)
M9NL	D-M9NL	3 wire/NPN	3	N.O. (A contact)
M9PL	D-M9PL	3 wire/PNP	3	N.O. (A contact)
M9BL	D-M9BL	2 wire	3	N.O. (A contact)

### Proximity switch types

Symbol	Model	Wiring/Output type	Lead wire length (m)	Contact
GN	With sensor plate, without proximity switch	—	—	—
G	GX-F8A	3 wire/NPN	1	N.O. (A contact)
GD	GX-F8AI	3 wire/NPN	1	N.O. (A contact)
GB	GX-F8B	3 wire/NPN	1	N.C. (B contact)
GDB	GX-F8BI	3 wire/NPN	1	N.C. (B contact)
GU	GXL-8FU	2 wire/solid state	1	N.O. (A contact)
GUB	GXL-8FUB	2 wire/solid state	1	N.C. (B contact)

\* Refer to page 1082 for detailed specifications of proximity switches.

Note 1) Since vibration may increase with low speed operation, set the driver to be driven in half-step mode, and use 12 mm/s or more as a guide for speed.

### Allowable Moment (N·m)

#### Allowable static moment

Pitching	15.7
Rolling	15.7
Yawing	7.84

m : Transfer load (kg)

L1, L2 : Overhang to work piece center of gravity (mm)

a : Work piece acceleration (mm/sec<sup>2</sup>)

Me : Dynamic moment

#### Allowable dynamic moment

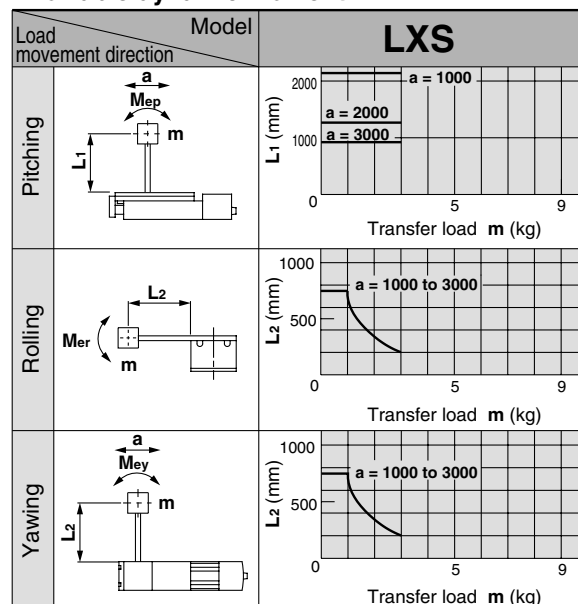

Refer to page 962 for deflection data.



# High Rigidity Slide Table Type 5 Phase Stepper Motor/Without Motor Brake **Series LXS**

## Dimensions/LXSH5SB

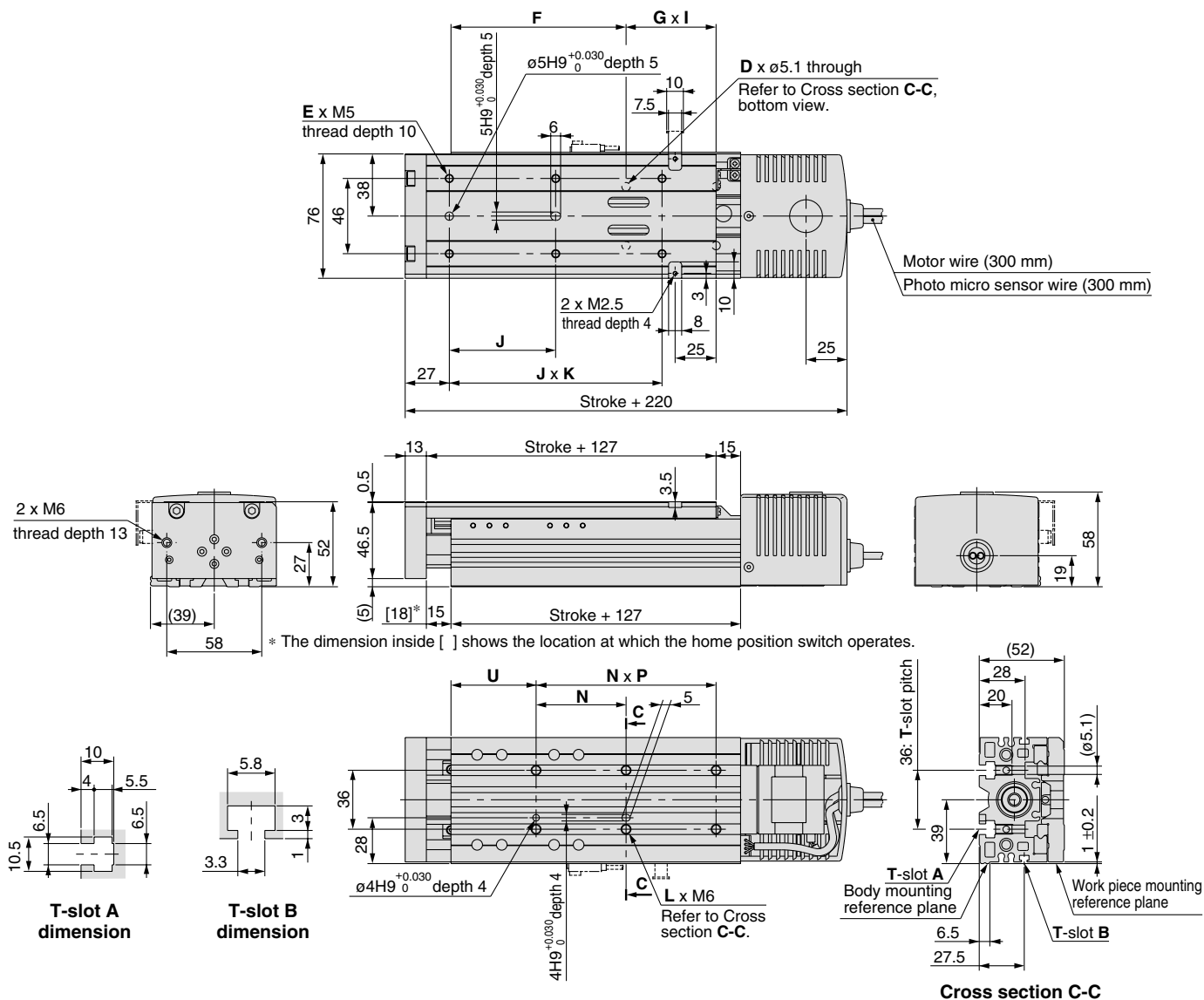

Model	D	E	F	G	I	J	K	L	N	P	U
LXSH5SB- 50	4	6	107	55	1	65	2	6	55	2	52
LXSH5SB- 75	4	6	112	65	1	75	2	6	65	2	47
LXSH5SB-100	4	8	122	75	1	65	3	6	75	2	47
LXSH5SB-125	4	8	132	85	1	70	3	6	85	2	47
LXSH5SB-150	6	8	112	65	2	75	3	8	65	3	47

Refer to page 959 for mounting.

## Positioning Time Guide (for Horizontal Mount)

For transfer load of 0 kg

		Positioning time (sec)				
		1	10	50	100	150
Speed (mm/s)	50	0.1	0.3	1.1	2.1	3.1
	100	0.1	0.2	0.6	1.1	1.6
	200	0.1	0.1	0.3	0.6	0.8

For transfer load of 3 kg

		Positioning time (sec)				
		1	10	50	100	150
Speed (mm/s)	50	0.1	0.3	1.1	2.1	3.1
	100	0.1	0.2	0.6	1.1	1.6
	200	0.1	0.2	0.4	0.6	0.9

For transfer load of 1.5 kg

		Positioning time (sec)				
		1	10	50	100	150
Speed (mm/s)	50	0.1	0.3	1.1	2.1	3.1
	100	0.1	0.2	0.6	1.1	1.6
	200	0.1	0.1	0.3	0.6	0.8

Refer to page 960 for acceleration time.

- LJ1
- LG1
- LTF
- LC1
- LC7
- LC8
- LXF
- LXP
- LXS
- LC6
- LZ
- LC3F2
- X
- D-
- E-MY

# High Rigidity Slide Table Type

## 5 Phase Stepper Motor

### With Motor Brake

# Series LXS

High Rigidity  
Direct Acting  
Guide

Ball Screw  
ø8 mm/2 mm lead

### How to Order

**LXSH5 BC - 100 B - M9N 1**

#### Stroke (mm)

Refer to the standard stroke.

#### Home position switch

Nil	None
S	Yes (Cable length 0.3 m)

#### Auto/Proximity switch type

Nil	None
-----	------

Refer to the table on the right for auto/proximity switch part numbers.

#### Number of auto/proximity switches

1	1 pc.
2	2 pcs.
⋮	⋮
6	6 pcs.

When using both auto and proximity switches, list the proximity switch part number after the auto switch part number.  
Example) M9N1G2

### Specifications

		Standard stroke (mm)				
		50	75	100	125	150
Performance	Body mass (kg)	2.1	2.3	2.5	2.7	2.9
	Operating temperature range (°C)	5 to 40 (No condensation)				
	Work load (kg)	10 (4) horizontal/5 (4) vertical <small>Note 1)</small>				
	Speed (mm/s)	to 30 <small>Note 2)</small>				
	Positioning repeatability (mm)	±0.03				
Main parts	Motor	5 phase stepper motor (with brake)				
	Lead screw	Ball screw ø8 mm, 2 mm lead				
	Guide	High rigidity direct acting guide				
	Electromagnetic brake	Model	De-energized operating type			
	Static torque (N·m)	0.1 or more				
	Rated voltage (V)	24 DC ±5%				
	Power consumption (W)	5				
Home position switch	Model	Photo micro sensor EE-SX673 (Refer to page 1084 for details.)				
Driver	Model	LC6D-507AD-□ (Refer to page 964 for details.)				

### Auto switch types

Symbol	Model	Wiring/Output type	Lead wire length (m)	Contact
Nil	Without auto switch			
M9N	D-M9N	3 wire/NPN	0.5	N.O. (A contact)
M9P	D-M9P	3 wire/PNP	0.5	N.O. (A contact)
M9B	D-M9B	2 wire	0.5	N.O. (A contact)
F9G	D-F9G	3 wire/NPN	0.5	N.C. (B contact)
F9H	D-F9H	3 wire/PNP	0.5	N.C. (B contact)
F9GL	D-F9GL	3 wire/NPN	3	N.C. (B contact)
F9HL	D-F9HL	3 wire/PNP	3	N.C. (B contact)
M9NL	D-M9NL	3 wire/NPN	3	N.O. (A contact)
M9PL	D-M9PL	3 wire/PNP	3	N.O. (A contact)
M9BL	D-M9BL	2 wire	3	N.O. (A contact)

### Proximity switch types

Symbol	Model	Wiring/Output type	Lead wire length (m)	Contact
GN	With sensor plate, without proximity switch	—	—	—
G	GX-F8A	3 wire/NPN	1	N.O. (A contact)
GD	GX-F8AI	3 wire/NPN	1	N.O. (A contact)
GB	GX-F8B	3 wire/NPN	1	N.C. (B contact)
GDB	GX-F8BI	3 wire/NPN	1	N.C. (B contact)
GU	GXL-8FU	2 wire/solid state	1	N.O. (A contact)
GUB	GXL-8FUB	2 wire/solid state	1	N.C. (B contact)

\* Refer to page 1082 for detailed specifications of proximity switches.



### Made to order specifications (For details, refer to page 999)

Symbol	Specifications
X20	AC servomotor specification
X60	Low particle generation specification

Note 1) When mounting a work piece to the actuator's end plate, its mass should be within the value inside ( ).

Note 2) Since vibration may increase with low speed operation, set the driver to be driven in half-step mode, and use 2 mm/s or more as a guide for speed.

### Allowable Moment (N·m)

#### Allowable static moment

Pitching	15.7
Yawing	7.84

m : Transfer load (kg)

L1, L2 : Overhang to work piece center of gravity (mm)

a : Work piece acceleration (mm/sec<sup>2</sup>)

Me : Dynamic moment

#### Allowable dynamic moment

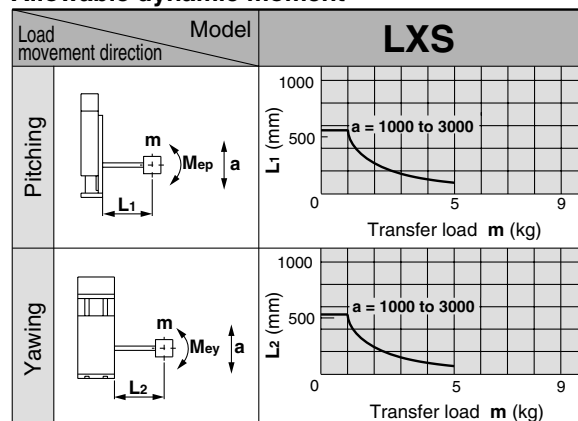

Refer to page 962 for deflection data.

# High Rigidity Slide Table Type 5 Phase Stepper Motor/With Motor Brake **Series LXS**

## Dimensions/LXSH5BC

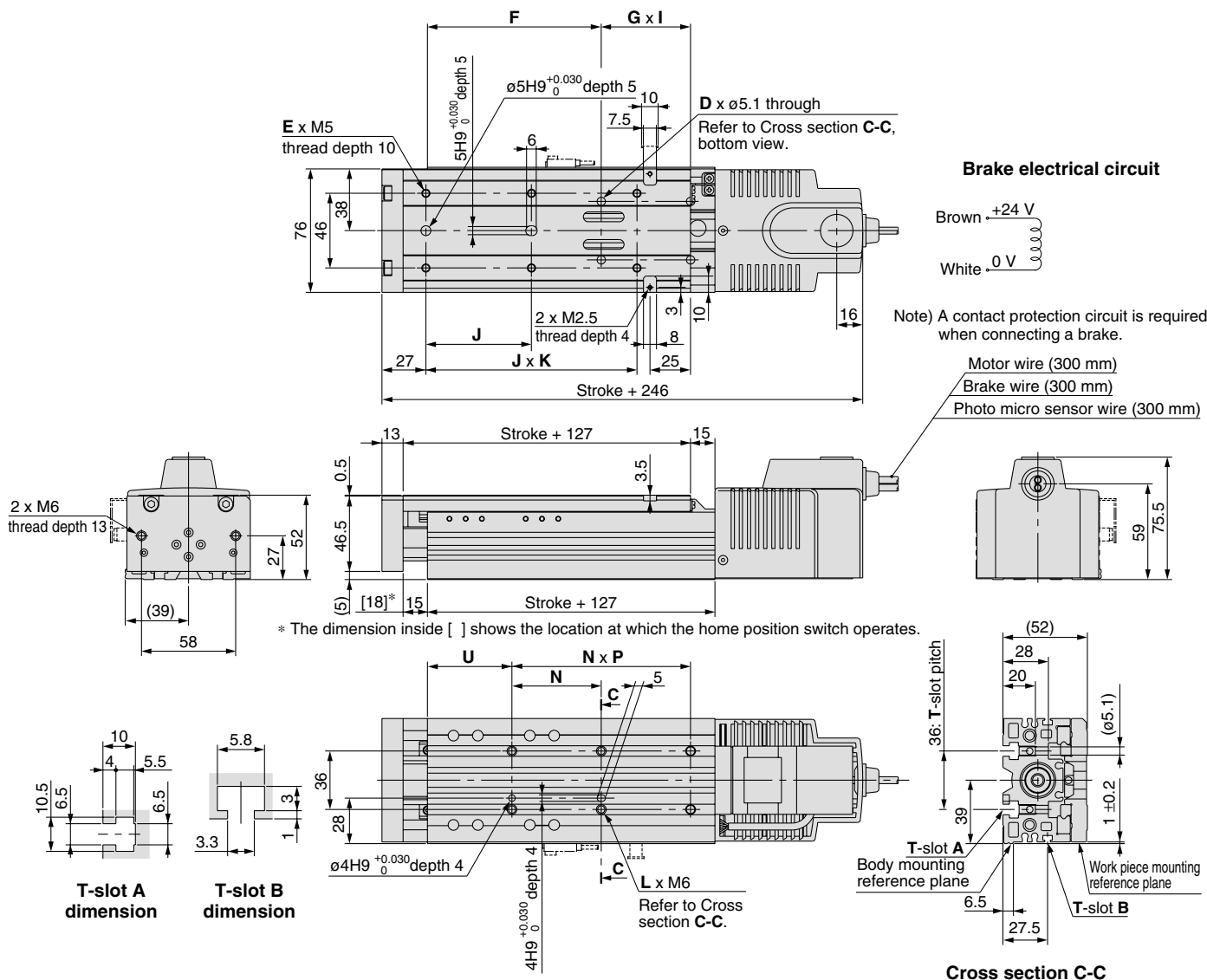

- LJ1
- LG1
- LTF
- LC1
- LC7
- LC8
- LXF
- LXP
- LXS**
- LC6□
- LZ□
- LC3F2
- X□
- D-□
- E-MY

Model	D	E	F	G	I	J	K	L	N	P	U
LXSH5BC- 50□B	4	6	107	55	1	65	2	6	55	2	52
LXSH5BC- 75□B	4	6	112	65	1	75	2	6	65	2	47
LXSH5BC-100□B	4	8	122	75	1	65	3	6	75	2	47
LXSH5BC-125□B	4	8	132	85	1	70	3	6	85	2	47
LXSH5BC-150□B	6	8	112	65	2	75	3	8	65	3	47

Refer to page 959 for mounting.

## Positioning Time Guide (for Vertical Mount)

### For transfer load of 0 kg

Positioning distance (mm)		Positioning time (sec)				
		1	10	50	100	150
Speed (mm/s)	10	0.2	1.1	5.1	10.1	15.1
	20	0.1	0.6	2.6	5.1	7.6
	30	0.1	0.4	1.7	3.4	5.1

### For transfer load of 5 kg

Positioning distance (mm)		Positioning time (sec)				
		1	10	50	100	150
Speed (mm/s)	10	0.2	1.1	5.1	10.1	15.1
	20	0.1	0.6	2.6	5.1	7.6
	30	0.1	0.4	1.7	3.4	5.1

### For transfer load of 2.5 kg

Positioning distance (mm)		Positioning time (sec)				
		1	10	50	100	150
Speed (mm/s)	10	0.2	1.1	5.1	10.1	15.1
	20	0.1	0.6	2.6	5.1	7.6
	30	0.1	0.4	1.7	3.4	5.1

Refer to page 961 for acceleration time.

# High Rigidity Slide Table Type

## 5 Phase Stepper Motor

### With Motor Brake

# Series LXS

High Rigidity  
Direct Acting  
Guide

Ball Screw  
ø8 mm/5 mm lead

### How to Order

**LXSH5BD - 100 B - M9N 1**

**Stroke (mm)**  
Refer to the standard stroke.

**Home position switch**

Nil	None
S	Yes (Cable length 0.3 m)

**Auto/Proximity switch type**

Nil	None
-----	------

**Number of auto/proximity switches**

1	1 pc.
2	2 pcs.
⋮	⋮
6	6 pcs.

When using both auto and proximity switches, list the proximity switch part number after the auto switch part number.  
Example) M9N1G2

### Specifications

Standard stroke (mm)		50	75	100	125	150	
Performance	Body mass (kg)	2.1	2.3	2.5	2.7	2.9	
	Operating temperature range (°C)	5 to 40 (No condensation)					
	Work load (kg)	10 (4) horizontal/5 (4) vertical (Note 1)					
	Speed (mm/s)	to 80 (Note 2)					
	Positioning repeatability (mm)	±0.03					
Main parts	Motor	5 phase stepper motor (with brake)					
	Lead screw	Ball screw ø8 mm, 5 mm lead					
	Guide	High rigidity direct acting guide					
	Electromagnetic brake	Model	De-energized operating type				
		Static torque (N·m)	0.1 or more				
Rated voltage (V)		24 DC ±5%					
	Power consumption (W)	5					
Home position switch	Model	Photo micro sensor EE-SX673 (Refer to page 1084 for details.)					
Driver	Model	LC6D-507AD-□ (Refer to page 964 for details.)					

### Auto switch types

Symbol	Model	Wiring/Output type	Lead wire length (m)	Contact
Nil	Without auto switch			
M9N	D-M9N	3 wire/NPN	0.5	N.O. (A contact)
M9P	D-M9P	3 wire/PNP	0.5	N.O. (A contact)
M9B	D-M9B	2 wire	0.5	N.O. (A contact)
F9G	D-F9G	3 wire/NPN	0.5	N.C. (B contact)
F9H	D-F9H	3 wire/PNP	0.5	N.C. (B contact)
F9GL	D-F9GL	3 wire/NPN	3	N.C. (B contact)
F9HL	D-F9HL	3 wire/PNP	3	N.C. (B contact)
M9NL	D-M9NL	3 wire/NPN	3	N.O. (A contact)
M9PL	D-M9PL	3 wire/PNP	3	N.O. (A contact)
M9BL	D-M9BL	2 wire	3	N.O. (A contact)

### Proximity switch types

Symbol	Model	Wiring/Output type	Lead wire length (m)	Contact
GN	With sensor plate, without proximity switch	—	—	—
G	GX-F8A	3 wire/NPN	1	N.O. (A contact)
GD	GX-F8AI	3 wire/NPN	1	N.O. (A contact)
GB	GX-F8B	3 wire/NPN	1	N.C. (B contact)
GDB	GX-F8BI	3 wire/NPN	1	N.C. (B contact)
GU	GXL-8FU	2 wire/solid state	1	N.O. (A contact)
GUB	GXL-8FUB	2 wire/solid state	1	N.C. (B contact)

\* Refer to page 1082 for detailed specifications of proximity switches.



**Made to order specifications**  
(For details, refer to page 999)

Symbol	Specifications
X20	AC servomotor specification
X60	Low particle generation specification

Note 1) When mounting a work piece to the actuator's end plate, its mass should be within the value inside ( ).

Note 2) Since vibration may increase with low speed operation, set the driver to be driven in half-step mode, and use 5 mm/s or more as a guide for speed.

### Allowable Moment (N·m)

#### Allowable static moment

Pitching	15.7
Yawing	7.84

m : Transfer load (kg)  
L1, L2 : Overhang to work piece center of gravity (mm)  
a : Work piece acceleration (mm/sec<sup>2</sup>)  
Me : Dynamic moment

#### Allowable dynamic moment

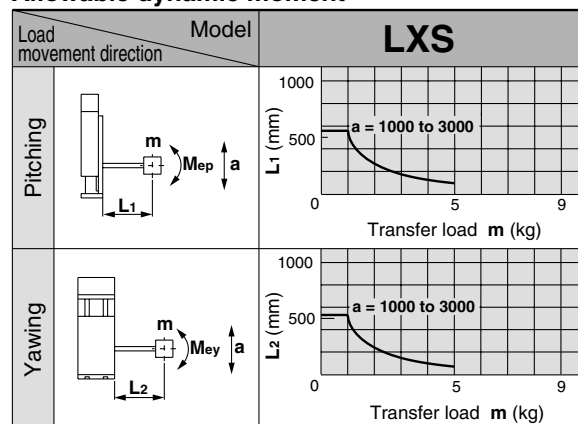

Refer to page 962 for deflection data.

# High Rigidity Slide Table Type 5 Phase Stepper Motor/With Motor Brake **Series LXS**

## Dimensions/LXSH5BD

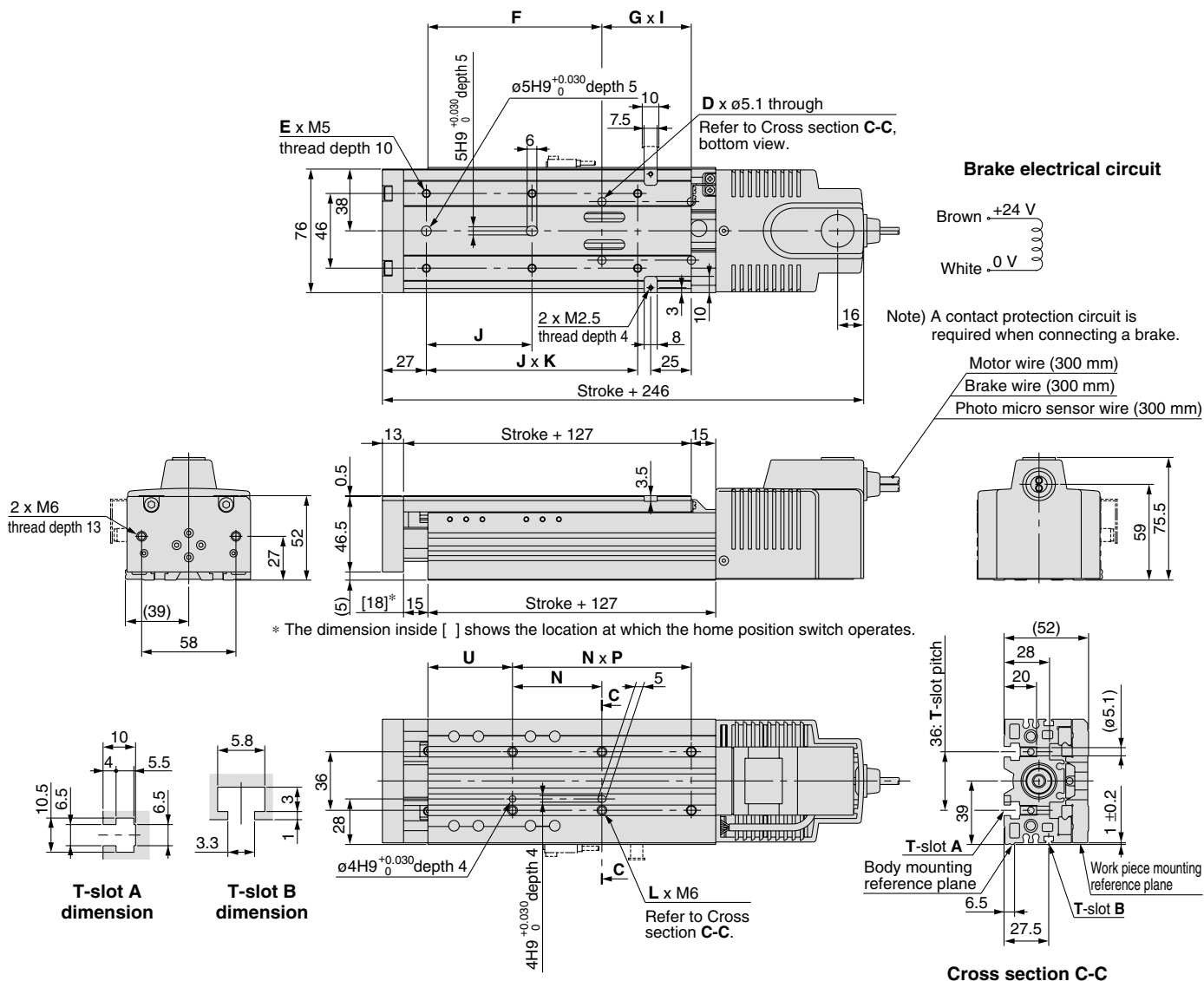

- LJ1
- LG1
- LTF
- LC1
- LC7
- LC8
- LXF
- LXP
- LXS**
- LC6□
- LZ□
- LC3F2
- X□
- D-□
- E-MY

## Positioning Time Guide (for Vertical Mount)

### For transfer load of 0 kg

		Positioning time (sec)				
		1	10	50	100	150
Speed (mm/s)	10	0.2	1.1	5.1	10.1	15.1
	40	0.1	0.3	1.3	2.6	3.8
	80	0.1	0.2	0.7	1.3	1.9

### For transfer load of 5 kg

		Positioning time (sec)				
		1	10	50	100	150
Speed (mm/s)	10	0.2	1.1	5.1	10.1	15.1
	40	0.1	0.3	1.3	2.6	3.8
	80	0.1	0.2	0.7	1.3	2.0

### For transfer load of 2.5 kg

		Positioning time (sec)				
		1	10	50	100	150
Speed (mm/s)	10	0.2	1.1	5.1	10.1	15.1
	40	0.1	0.3	1.3	2.6	3.8
	80	0.1	0.2	0.7	1.3	2.0

Refer to page 961 for acceleration time.

# High Rigidity Slide Table Type

## 5 Phase Stepper Motor

### With Motor Brake

# Series LXS

High Rigidity  
Direct Acting  
Guide

Slide Screw  
ø8 mm/6 mm lead

### How to Order

**LXSH5 SA - 100 B - M9N 1**

#### Stroke (mm)

Refer to the standard stroke.

#### Home position switch

Nil	None
S	Yes (Cable length 0.3 m)

#### Auto/Proximity switch type

Nil	None
-----	------

Refer to the table on the right for auto/proximity switch part numbers.

#### Number of auto/proximity switches

1	1 pc.
2	2 pcs.
⋮	⋮
6	6 pcs.

When using both auto and proximity switches, list the proximity switch part number after the auto switch part number.  
Example) M9N1G2

### Specifications

Standard stroke (mm)		50	75	100	125	150	
Performance	Body mass (kg)	2.1	2.3	2.5	2.7	2.9	
	Operating temperature range (°C)	5 to 40 (No condensation)					
	Work load (kg)	6 (4) horizontal/2 (2) vertical <small>Note 1)</small>					
	Speed (mm/s)	to 100 <small>Note 2)</small>					
	Positioning repeatability (mm)	±0.05					
Main parts	Motor	5 phase stepper motor (with brake)					
	Lead screw	Slide screw ø8 mm, 6 mm lead					
	Guide	High rigidity direct acting guide					
	Electromagnetic brake	Model	De-energized operating type				
		Static torque (N·m)	0.1 or more				
Rated voltage (V)		24 DC ±5%					
Power consumption (W)	5						
Home position switch	Model	Photo micro sensor EE-SX673 (Refer to page 1084 for details.)					
Driver	Model	LC6D-507AD-□ (Refer to page 964 for details.)					

### Auto switch types

Symbol	Model	Wiring/Output type	Lead wire length (m)	Contact
Nil	Without auto switch			
M9N	D-M9N	3 wire/NPN	0.5	N.O. (A contact)
M9P	D-M9P	3 wire/PNP	0.5	N.O. (A contact)
M9B	D-M9B	2 wire	0.5	N.O. (A contact)
F9G	D-F9G	3 wire/NPN	0.5	N.C. (B contact)
F9H	D-F9H	3 wire/PNP	0.5	N.C. (B contact)
F9GL	D-F9GL	3 wire/NPN	3	N.C. (B contact)
F9HL	D-F9HL	3 wire/PNP	3	N.C. (B contact)
M9NL	D-M9NL	3 wire/NPN	3	N.O. (A contact)
M9PL	D-M9PL	3 wire/PNP	3	N.O. (A contact)
M9BL	D-M9BL	2 wire	3	N.O. (A contact)

### Proximity switch types

Symbol	Model	Wiring/Output type	Lead wire length (m)	Contact
GN	With sensor plate, without proximity switch	—	—	—
G	GX-F8A	3 wire/NPN	1	N.O. (A contact)
GD	GX-F8AI	3 wire/NPN	1	N.O. (A contact)
GB	GX-F8B	3 wire/NPN	1	N.C. (B contact)
GDB	GX-F8BI	3 wire/NPN	1	N.C. (B contact)
GU	GXL-8FU	2 wire/solid state	1	N.O. (A contact)
GUB	GXL-8FUB	2 wire/solid state	1	N.C. (B contact)

\* Refer to page 1082 for detailed specifications of proximity switches.

Note 1) When mounting a work piece to the actuator's end plate, its mass should be within the value inside ( ).

Note 2) Since vibration may increase with low speed operation, set the driver to be driven in half-step mode, and use 6 mm/s or more as a guide for speed.

### Allowable Moment (N·m)

#### Allowable static moment

Pitching	15.7
Yawing	7.84

m : Transfer load (kg)

L1, L2 : Overhang to work piece center of gravity (mm)

a : Work piece acceleration (mm/sec<sup>2</sup>)

Me : Dynamic moment

#### Allowable dynamic moment

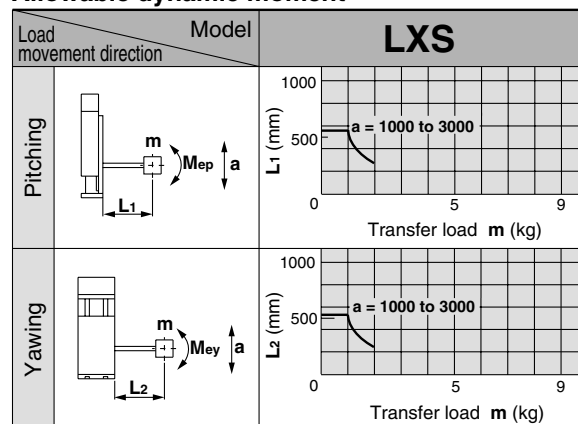

Refer to page 962 for deflection data.

# High Rigidity Slide Table Type 5 Phase Stepper Motor/With Motor Brake **Series LXS**

## Dimensions/LXSH5SA

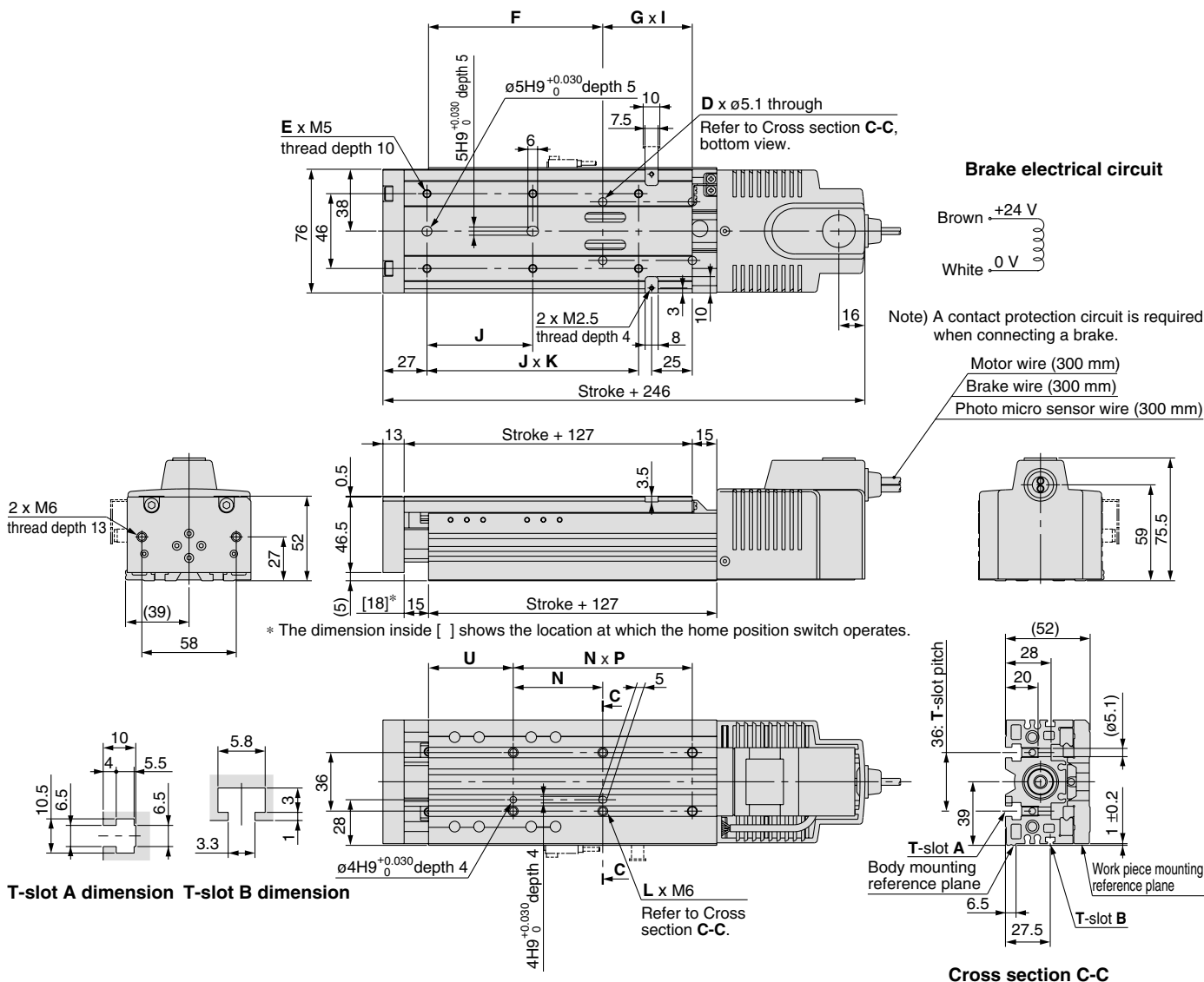

Model	D	E	F	G	I	J	K	L	N	P	U
LXSH5SA- 50□B	4	6	107	55	1	65	2	6	55	2	52
LXSH5SA- 75□B	4	6	112	65	1	75	2	6	65	2	47
LXSH5SA-100□B	4	8	122	75	1	65	3	6	75	2	47
LXSH5SA-125□B	4	8	132	85	1	70	3	6	85	2	47
LXSH5SA-150□B	6	8	112	65	2	75	3	8	65	3	47

Refer to page 959 for mounting.

## Positioning Time Guide (for Vertical Mount)

### For transfer load of 0 kg

Positioning distance (mm)		Positioning time (sec)				
		1	10	50	100	150
Speed (mm/s)	10	0.2	1.1	5.1	10.1	15.1
	50	0.1	0.3	1.1	2.1	3.1
	100	0.1	0.2	0.6	1.1	1.6

### For transfer load of 2 kg

Positioning distance (mm)		Positioning time (sec)				
		1	10	50	100	150
Speed (mm/s)	10	0.2	1.1	5.1	10.1	15.1
	50	0.1	0.3	1.1	2.1	3.1
	100	0.1	0.2	0.6	1.1	1.6

### For transfer load of 1 kg

Positioning distance (mm)		Positioning time (sec)				
		1	10	50	100	150
Speed (mm/s)	10	0.2	1.1	5.1	10.1	15.1
	50	0.1	0.3	1.1	2.1	3.1
	100	0.1	0.2	0.6	1.1	1.6

Refer to page 960 for acceleration time.

- LJ1
- LG1
- LTF
- LC1
- LC7
- LC8
- LXF
- LXP
- LXS**
- LC6□
- LZ□
- LC3F2
- X□
- D-□
- E-MY

# High Rigidity Slide Table Type 5 Phase Stepper Motor With Motor Brake Series LXS

High Rigidity  
Direct Acting  
Guide

Slide Screw  
∅8 mm/12 mm lead

## How to Order

LXSH5 **SB** - **100** **B** - **M9N** **1**

### Stroke (mm)

Refer to the standard stroke.

### Home position switch

Nil	None
S	Yes (Cable length 0.3 m)

### Auto/Proximity switch type

Nil	None
-----	------

Refer to the table on the right for auto/proximity switch part numbers.

### Number of auto/proximity switches

1	1 pc.
2	2 pcs.
⋮	⋮
6	6 pcs.

When using both auto and proximity switches, list the proximity switch part number after the auto switch part number.  
Example) M9N1G2

## Specifications

Standard stroke (mm)		50	75	100	125	150	
Performance	Body mass (kg)	2.1	2.3	2.5	2.7	2.9	
	Operating temperature range (°C)	5 to 40 (No condensation)					
	Work load (kg)	3 (3) horizontal/1 (1) vertical <sup>Note 1)</sup>					
	Speed (mm/s)	to 200 <sup>Note 2)</sup>					
	Positioning repeatability (mm)	±0.05					
Main parts	Motor	5 phase stepper motor (with brake)					
	Lead screw	Slide screw ∅8 mm, 12 mm lead					
	Guide	High rigidity direct acting guide					
	Electromagnetic brake	Model	De-energized operating type				
		Static torque (N·m)	0.1 or more				
Rated voltage (V)		24 DC ±5%					
	Power consumption (W)	5					
Home position switch	Model	Photo micro sensor EE-SX673 (Refer to page 1084 for details.)					
Driver	Model	LC6D-507AD-□ (Refer to page 964 details.)					

## Auto switch types

Symbol	Model	Wiring/Output type	Lead wire length (m)	Contact
Nil	Without auto switch			
M9N	D-M9N	3 wire/NPN	0.5	N.O. (A contact)
M9P	D-M9P	3 wire/PNP	0.5	N.O. (A contact)
M9B	D-M9B	2 wire	0.5	N.O. (A contact)
F9G	D-F9G	3 wire/NPN	0.5	N.C. (B contact)
F9H	D-F9H	3 wire/PNP	0.5	N.C. (B contact)
F9GL	D-F9GL	3 wire/NPN	3	N.C. (B contact)
F9HL	D-F9HL	3 wire/PNP	3	N.C. (B contact)
M9NL	D-M9NL	3 wire/NPN	3	N.O. (A contact)
M9PL	D-M9PL	3 wire/PNP	3	N.O. (A contact)
M9BL	D-M9BL	2 wire	3	N.O. (A contact)

## Proximity switch types

Symbol	Model	Wiring/Output type	Lead wire length (m)	Contact
GN	With sensor plate, without proximity switch	—	—	—
G	GX-F8A	3 wire/NPN	1	N.O. (A contact)
GD	GX-F8AI	3 wire/NPN	1	N.O. (A contact)
GB	GX-F8B	3 wire/NPN	1	N.C. (B contact)
GDB	GX-F8BI	3 wire/NPN	1	N.C. (B contact)
GU	GXL-8FU	2 wire/solid state	1	N.O. (A contact)
GUB	GXL-8FUB	2 wire/solid state	1	N.C. (B contact)

\* Refer to page 1082 for detailed specifications of proximity switches.

Note 1) When mounting a work piece to the actuator's end plate, its mass should be within the value inside ( ).

Note 2) Since vibration may increase with low speed operation, set the driver to be driven in half-step mode, and use 12 mm/s or more as a guide for speed.

## Allowable Moment (N·m)

### Allowable static moment

Pitching	15.7
Yawing	7.84

m : Transfer load (kg)

L1, L2 : Overhang to work piece center of gravity (mm)

a : Work piece acceleration (mm/sec<sup>2</sup>)

Me : Dynamic moment

### Allowable dynamic moment

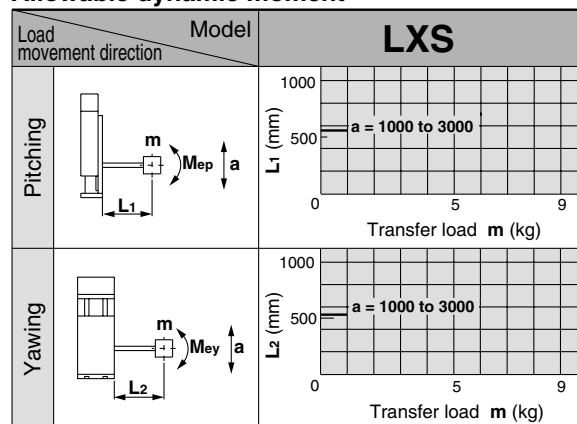

Refer to page 962 for deflection data.



# High Rigidity Slide Table Type 5 Phase Stepper Motor/With Motor Brake **Series LXS**

## Dimensions/LXSH5SB

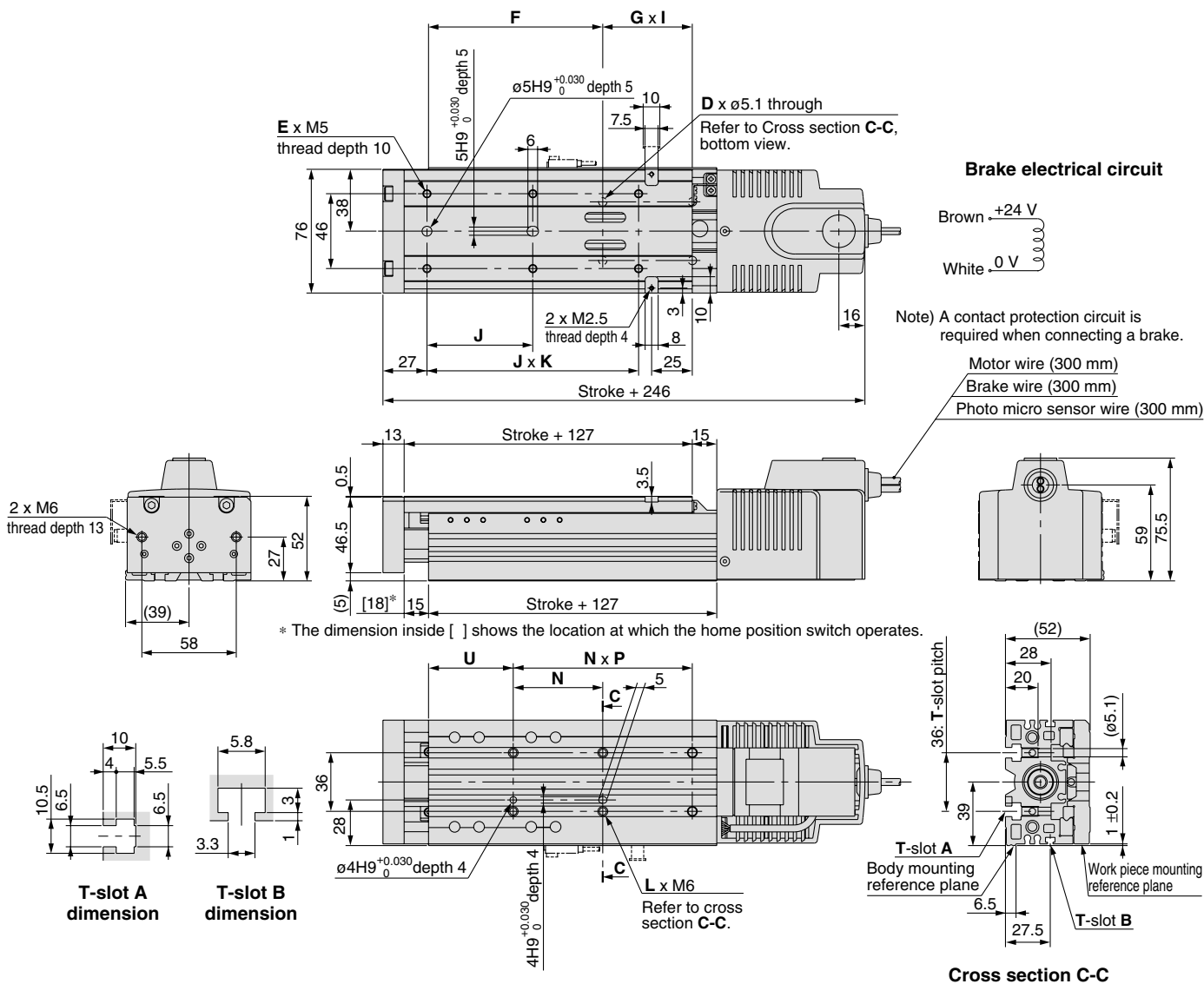

- LJ1
- LG1
- LTF
- LC1
- LC7
- LC8
- LXF
- LXP
- LXS**
- LC6□
- LZ□
- LC3F2
- X□
- D-□
- E-MY

Model	D	E	F	G	I	J	K	L	N	P	U
LXSH5SB- 50□B	4	6	107	55	1	65	2	6	55	2	52
LXSH5SB- 75□B	4	6	112	65	1	75	2	6	65	2	47
LXSH5SB-100□B	4	8	122	75	1	65	3	6	75	2	47
LXSH5SB-125□B	4	8	132	85	1	70	3	6	85	2	47
LXSH5SB-150□B	6	8	112	65	2	75	3	8	65	3	47

Refer to page 959 for mounting.

## Positioning Time Guide (for Vertical Mount)

### For transfer load of 0 kg

Positioning distance (mm)		Positioning time (sec)				
		1	10	50	100	150
Speed (mm/s)	50	0.1	0.3	1.1	2.1	3.1
	100	0.1	0.2	0.6	1.1	1.6
	200	0.1	0.1	0.3	0.6	0.8

### For transfer load of 1 kg

Positioning distance (mm)		Positioning time (sec)				
		1	10	50	100	150
Speed (mm/s)	50	0.1	0.3	1.1	2.1	3.1
	100	0.1	0.2	0.6	1.1	1.6
	200	0.1	0.1	0.3	0.6	0.8

Refer to page 960 for acceleration time.

# Low Profile Slide Table Type Without Motor Brake Series LXF



## How to Order

### Slide screw specification

**LX F H 5 S B - 50 - M9N 1 - Q**

#### Actuator configuration

**F** Flat table type

#### Guide type

**H** Direct acting guide

#### Motor type

**5** 5 phase stepper motor

#### Lead screw type

**S** Slide screw

#### Lead screw lead

<b>A</b>	6 mm
<b>B</b>	12 mm

#### Stroke

<b>25</b>	25 mm
<b>50</b>	50 mm
<b>75</b>	75 mm
<b>100</b>	100 mm

#### Home position switch

<b>Nil</b>	None
<b>S</b>	Yes (Cable length 0.3 m)

Use a driver with CE marking.

#### CE marking

#### Number of auto switches/proximity switches

<b>1</b>	1 pc.
<b>2</b>	2 pcs.
<b>⋮</b>	<b>⋮</b>
<b>6</b>	6 pcs.

When using both auto and proximity switches, list the proximity switch part number after the auto switch part number.  
Example) M9N1G2

#### Auto switch type

Symbol	Model	Wiring/Output type	Lead wire length (m)	Contact
<b>Nil</b>	Without auto switch			
<b>M9N</b>	<b>D-M9N</b>	3 wire/NPN	0.5	N.O. (A contact)
<b>M9P</b>	<b>D-M9P</b>	3 wire/PNP	0.5	N.O. (A contact)
<b>M9B</b>	<b>D-M9B</b>	2 wire	0.5	N.O. (A contact)
<b>F9G</b>	<b>D-F9G</b>	3 wire/NPN	0.5	N.C. (B contact)
<b>F9H</b>	<b>D-F9H</b>	3 wire/PNP	0.5	N.C. (B contact)
<b>F9GL</b>	<b>D-F9GL</b>	3 wire/NPN	3	N.C. (B contact)
<b>F9HL</b>	<b>D-F9HL</b>	3 wire/PNP	3	N.C. (B contact)
<b>M9NL</b>	<b>D-M9NL</b>	3 wire/NPN	3	N.O. (A contact)
<b>M9PL</b>	<b>D-M9PL</b>	3 wire/PNP	3	N.O. (A contact)
<b>M9BL</b>	<b>D-M9BL</b>	2 wire	3	N.O. (A contact)

#### Proximity switch types

Symbol	Model	Wiring/Output type	Lead wire length (m)	Contact
<b>GN</b>	With sensor rail, without proximity switch	—	—	—
<b>G</b>	<b>GX-F8A</b>	3 wire/NPN	1	N.O. (A contact)
<b>GD</b>	<b>GX-F8AI</b>	3 wire/NPN	1	N.O. (A contact)
<b>GB</b>	<b>GX-F8B</b>	3 wire/NPN	1	N.C. (B contact)
<b>GDB</b>	<b>GX-F8BI</b>	3 wire/NPN	1	N.C. (B contact)
<b>GU</b>	<b>GXL-8FU</b>	2 wire/solid state	1	N.O. (A contact)
<b>GUB</b>	<b>GXL-8FUB</b>	2 wire/solid state	1	N.C. (B contact)

\* Refer to page 1082 for detailed specifications of proximity switches.

## Specifications

<b>Motor</b>	5 phase stepper motor (without brake)	
<b>Lead screw (mm)</b>	Slide screw $\varnothing 8$ mm	
<b>Positioning repeatability (mm)</b>	$\pm 0.05$	
<b>Lead (mm)</b>	6	12
<b>Speed (mm/s)</b> <small>Note 1)</small>	3 to 100	6 to 200
<b>Work load (kg)</b> <small>Note 2)</small> <b>Horizontal</b>	3 (2)	2 (2)
<b>Guide type</b>	Direct acting guide	
<b>Operating temperature range (°C)</b>	5 to 40 (No condensation)	
<b>Home position switch</b>	Photo micro sensor EE-SX672 (Refer to page 1084 for details.)	
<b>Applicable driver</b>	LC6D-507AD-Q, LC6D-507AD-P1-X316 (Refer to page 964 for details.)	
<b>CE marking accessories</b>	Holding plate: MB1 (1 pc.), Phillips countersunk head screw M3 x 6 $\ell$ (1 pc.) Phillips binding head screw: M3 x 4 $\ell$ (2 pcs.), Toothed lock washer M3 (2 pcs.) Binding band: T18S (1 pc.)	

Note 1) Since vibration may increase with low speed operation, set the driver to be driven in half-step mode, and use 6 mm/s or more for 6 mm lead, and 12 mm/s or more for 12 mm lead as a guide for speed.

Note 2) When mounting a work piece to the actuator's end plate, its mass should be within the value inside ( ).

## Mass

Model	Standard stroke (mm)			
	25	50	75	100
<b>LXFH5S</b>	0.8	1.0	1.1	1.2

For basic specifications such as allowable moment, refer to the "Standard" pages for equivalent products listed on Features pages 462 and 463.

LJ1

LG1

LTF

LC1

LC7

LC8

LXF

LXP

LXS

LC6 LZ 

LC3F2

X D- 

E-MY

# Low Profile Slide Table Type Without Motor Brake Series LXF



## How to Order

### Ball screw specification

**LX F H 5 B C - 50 - GD 1 - Q**

Actuator configuration: **F** Flat table type

Guide type: **H** Direct acting guide

Motor type: **5** 5 phase stepper motor

Lead screw type: **B** Ball screw

Lead screw lead: **C** 2 mm, **D** 5 mm

Stroke: **25** 25 mm, **50** 50 mm, **75** 75 mm, **100** 100 mm

CE marking

Number of auto switches:

1	1 pc.
2	2 pcs.
⋮	⋮
6	6 pcs.

Proximity switch types:

Symbol	Model	Wiring/Output type	Lead wire length (m)	Contact
GN	With sensor rail, without proximity switch	—	—	—
G	GX-F8A	3 wire/NPN	1	N.O. (A contact)
GD	GX-F8AI	3 wire/NPN	1	N.O. (A contact)
GB	GX-F8B	3 wire/NPN	1	N.C. (B contact)
GDB	GX-F8BI	3 wire/NPN	1	N.C. (B contact)
GU	GXL-8FU	2 wire/solid state	1	N.O. (A contact)
GUB	GXL-8FUB	2 wire/solid state	1	N.C. (B contact)

\* Refer to page 1082 for detailed specifications of proximity switches.

Home position switch:

Nil	None
S	Yes (Cable length 0.3 m)

Use a driver with CE marking.

## Specifications

Motor	5 phase stepper motor (without brake)		
Lead screw (mm)	Ball screw ø8 mm		
Positioning repeatability (mm)	±0.03		
Lead (mm)	2	5	
Speed (mm/s) <sup>Note 1)</sup>	2 to 30	5 to 80	
Work load (kg) <sup>Note 2)</sup>	Horizontal	3 (2)	3 (2)
Guide type	Direct acting guide		
Operating temperature range (°C)	5 to 40 (No condensation)		
Home position switch	Photo micro sensor EE-SX672 (Refer to page 1084 for details.)		
Applicable driver	LC6D-507AD-Q, LC6D-507AD-P1-X316 (Refer to page 964 for details.)		
CE marking accessories	Holding plate: MB1(1 pc.), Phillips countersunk head screw M3 x 6 ℓ (1 pc.) Phillips binding head screw: M3 x 4 ℓ (2 pcs.), Toothed lock washer M3 (2 pcs.) Binding band: T18S (1 pc.)		

Note 1) Since vibration may increase with low speed operation, set the driver to be driven in half-step mode, and use 2 mm/s or more for 2 mm lead, and 5 mm/s or more for 5 mm lead as a guide for speed.

Note 2) When mounting a work piece to the actuator's end plate, its mass should be within the value inside ( ).

## Mass

Model	Standard stroke (mm)			
	25	50	75	100
LXFH5S	0.8	1.0	1.1	1.2

For basic specifications such as allowable moment, refer to the "Standard" pages for equivalent products listed on Features pages 462 and 463.

**Dimensions/LXFH5**

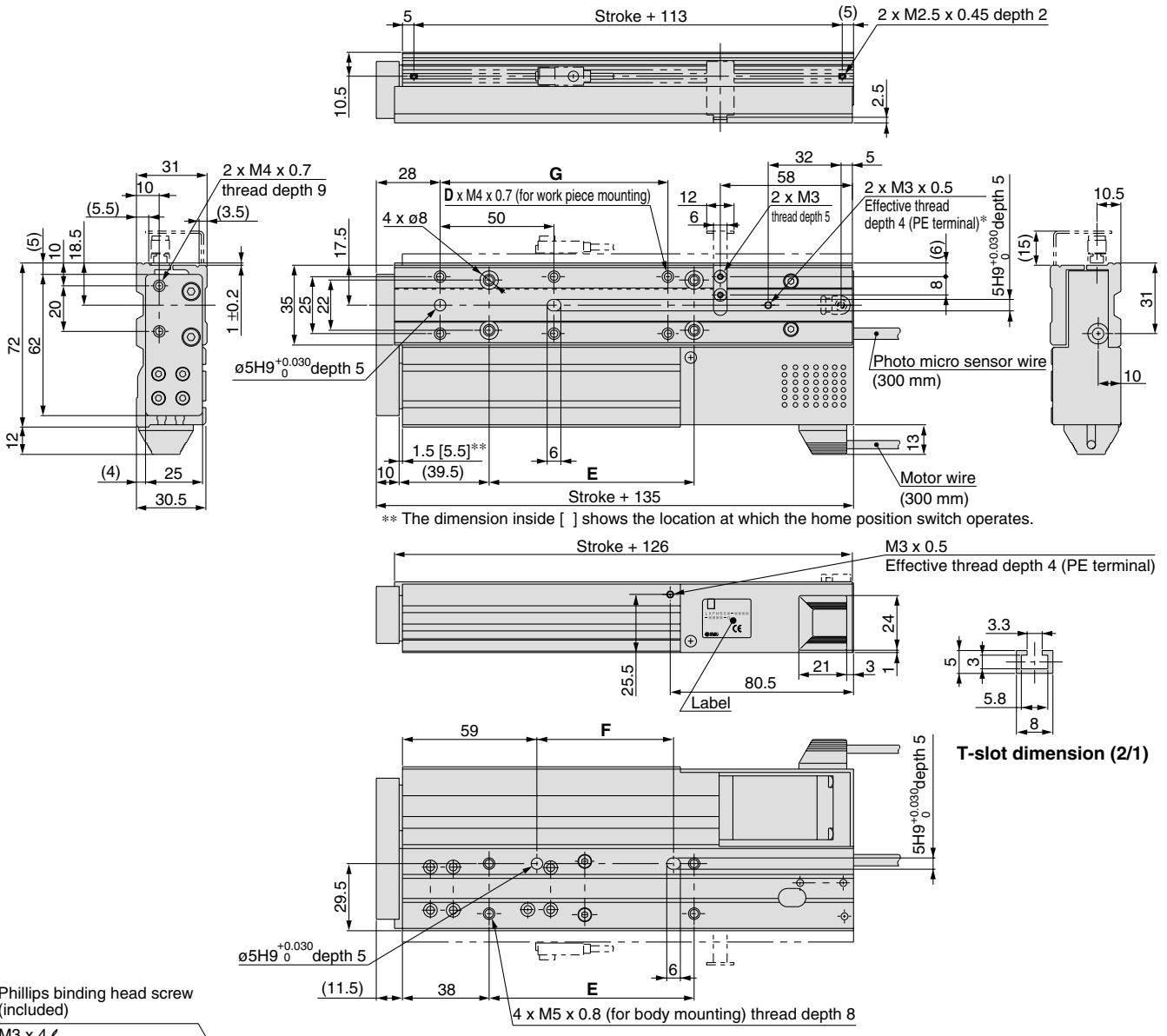

- LJ1
- LG1
- LTF
- LC1
- LC7
- LC8
- LXF**
- LXP
- LXS
- LC6□
- LZ□
- LC3F2
- X□
- D-□
- E-MY

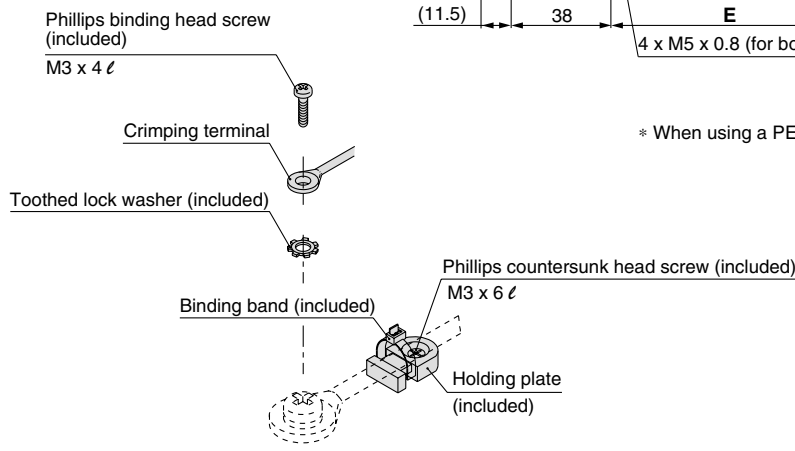

\* When using a PE terminal, use accessories included as shown on the left.

Refer to page 957 for mounting.

Model	D	E	F	G
LXFH5S□- 25	4	60	30	(50)
LXFH5S□- 50	4	90	60	(50)
LXFH5S□- 75	6	90	60	100
LXFH5S□-100	6	90	60	100

# Guide Rod Type With Motor Brake/ Without Motor Brake Series LXP



## How to Order

### Slide screw specification

**LXPB2SB-100 B-M9N1-Q**

**Actuator configuration**  
**P** Guide rod type

**Guide type**  
**B** Ball bushing

**Motor type**  
**2** 2 phase stepper motor  
**5** 5 phase stepper motor

**Lead screw type**  
**S** Slide screw

**Lead screw lead**  
**A** 6 mm  
**B** 12 mm

**Stroke**

50	50 mm
75	75 mm
100	100 mm
125	125 mm
150	150 mm
170	170 mm
200	200 mm

**Home position switch**

Nil	None
S	Yes (Cable length 0.3 m)

**Brake**

Nil	Without brake
B	With brake

**CE marking**

**Number of auto switches**

1	1 pc.
2	2 pcs.
⋮	⋮
6	6 pcs.

**Auto switch type**

Symbol	Model	Wiring/Output type	Lead wire length (m)	Contact
M9N	D-M9N	3 wire/NPN	0.5	N.O. (A contact)
M9P	D-M9P	3 wire/PNP	0.5	N.O. (A contact)
M9B	D-M9B	2 wire	0.5	N.O. (A contact)
F9G	D-F9G	3 wire/NPN	0.5	N.C. (B contact)
F9H	D-F9H	3 wire/PNP	0.5	N.C. (B contact)
F9GL	D-F9GL	3 wire/NPN	3	N.C. (B contact)
F9HL	D-F9HL	3 wire/PNP	3	N.C. (B contact)
M9NL	D-M9NL	3 wire/NPN	3	N.O. (A contact)
M9PL	D-M9PL	3 wire/PNP	3	N.O. (A contact)
M9BL	D-M9BL	2 wire	3	N.O. (A contact)

Use a driver with CE marking.

### Specifications

Motor	2 phase stepper motor (with/without brake)	5 phase stepper motor (with/without brake)			
Lead screw (mm)	Slide screw ø8 mm				
Positioning repeatability (mm)	±0.05				
Lead (mm)	6	12			
Speed (mm/s) <small>Note 1)</small>	3 to 100	6 to 200			
Work load (kg)	Horizontal	6	3	4	2
	Vertical	5	3	4	2
Guide type	Ball bushing				
Operating temperature range (°C)	5 to 40 (No condensation)				
Home position switch	Photo micro sensor EE-SX673 (Refer to page 1084 for details.)				
Brake specifications	Model	De-energized operating type			
	Static torque (N·m)	0.1			
	Rated voltage (V [DC])	24 ±5%			
	Power consumption (W)	5 (at 75°C)			
Applicable driver	LC6D-220AD-Q (Refer to page 964 details.)	LC6D-507AD-Q (Refer to page 964 for details.)			
CE marking accessories	Holding plate: MB1(1 pc.), Phillips countersunk head screw M3 x 6 ℓ (1 pc.) Phillips binding head screw: M3 x 4 ℓ (2 pcs.), Toothed lock washer M3 (2 pcs.) Binding band: T18S (1 pc.)				

Note 1) Since vibration may increase with low speed operation, set the driver to be driven in half-step mode, and use 6 mm/s or more for 6 mm lead, and 12 mm/s or more for 12 mm lead as a guide for speed.

### Mass

Model	Standard stroke (mm)							Additional mass with motor
	50	75	100	125	150	175	200	With brake
LXPB <sub>2</sub> S	2.0	2.2	2.3	2.6	2.8	2.9	3.1	0.2

For basic specifications such as allowable moment, refer to the "Standard" pages for equivalent products listed on Features pages 462 and 463.  
946



# Guide Rod Type With Motor Brake/ Without Motor Brake Series LXP



## How to Order

### Ball screw specification

**LX P B 2 B C - 100 B - M9N 1 - Q**

**Actuator configuration**  
**P** Guide rod type

**Guide type**  
**B** Ball bushing

**Motor type**  
**2** 2 phase stepper motor  
**5** 5 phase stepper motor

**Lead screw type**  
**B** Ball screw

**Lead screw lead**  
**C** 2 mm  
**D** 5 mm

**Stroke**  

50	50 mm
75	75 mm
100	100 mm
125	125 mm
150	150 mm
170	170 mm
200	200 mm

**Home position switch**  

Nil	None
S	Yes (Cable length 0.3 m)

**Brake**  

Nil	Without brake
B	With brake

**CE marking**  
**Number of auto switches**  

1	1 pc.
2	2 pcs.
⋮	⋮
6	6 pcs.

**Auto switch type**

Symbol	Model	Wiring/Output type	Lead wire length (m)	Contact
M9N	D-M9N	3 wire/NPN	0.5	N.O. (A contact)
M9P	D-M9P	3 wire/PNP	0.5	N.O. (A contact)
M9B	D-M9B	2 wire	0.5	N.O. (A contact)
F9G	D-F9G	3 wire/NPN	0.5	N.C. (B contact)
F9H	D-F9H	3 wire/PNP	0.5	N.C. (B contact)
F9GL	D-F9GL	3 wire/NPN	3	N.C. (B contact)
F9HL	D-F9HL	3 wire/PNP	3	N.C. (B contact)
M9NL	D-M9NL	3 wire/NPN	3	N.O. (A contact)
M9PL	D-M9PL	3 wire/PNP	3	N.O. (A contact)
M9BL	D-M9BL	2 wire	3	N.O. (A contact)

Use a driver with CE marking.

### Specifications

Motor	2 phase stepper motor (with/without brake)	5 phase stepper motor (with/without brake)
Lead screw (mm)	Ball screw ø8 mm	
Positioning repeatability (mm)	±0.05	
Lead (mm)	2	5
Speed (mm/s) <small>Note 1)</small>	2 to 30	5 to 80
Work load (kg)	Horizontal	6
	Vertical	5
Guide type	Ball bushing	
Operating temperature range (°C)	5 to 40 (No condensation)	
Home position switch	Photo micro sensor EE-SX673 (Refer to page 1084 for details.)	
Brake specifications	Model	De-energized operating type
	Static torque (N·m)	0.1
	Rated voltage (V [DC])	24 ±5%
	Power consumption (W)	5 (at 75°C)
Applicable driver	LC6D-220AD-Q, LC6D-220AD-P1-X316 (Refer to page 964 details.)	LC6D-507AD-Q, LC6D-507AD-P1-X316 (Refer to page 964 for details.)
CE marking accessories	Holding plate: MB1(1 pc.), Phillips countersunk head screw M3 x 6 ℓ (1 pc.) Phillips binding head screw: M3 x 4 ℓ (2 pcs.), Toothed lock washer M3 (2 pcs.) Binding band: T18S (1 pc.)	

Note 1) Since vibration may increase with low speed operation, set the driver to be driven in half-step mode, and use 2 mm/s or more for 2 mm lead, and 5 mm/s or more for 5 mm lead as a guide for speed.

### Mass

Model	Standard stroke (mm)							Additional mass with motor With brake
	50	75	100	125	150	175	200	
LXP <sub>B</sub> <sup>2</sup> S	2.0	2.2	2.3	2.6	2.8	2.9	3.1	0.2

For basic specifications such as allowable moment, refer to the "Standard" pages for equivalent products listed on Features pages 462 and 463.

LJ1

LG1

LTF

LC1

LC7

LC8

LXF

LXP

LXS

LC6□

LZ□

LC3F2

X□

D-□

E-MY

# Series LXP

## Dimensions/LXPB<sup>2</sup><sub>5</sub>

When two dimensions are shown, the top dimension is for 50 to 75 and 100 mm strokes, and the bottom dimension is for 125, 150, 175, and 200 mm strokes.

### With brake

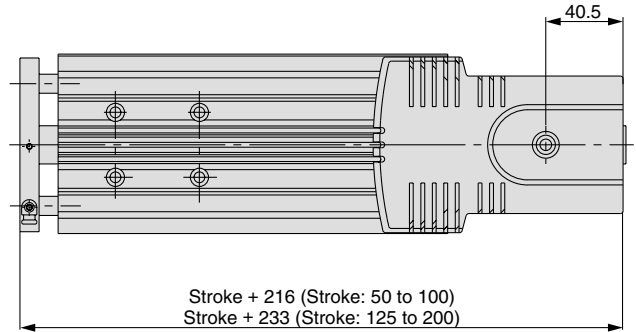
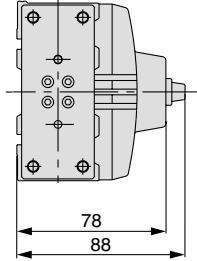
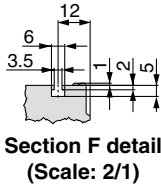

### Without brake

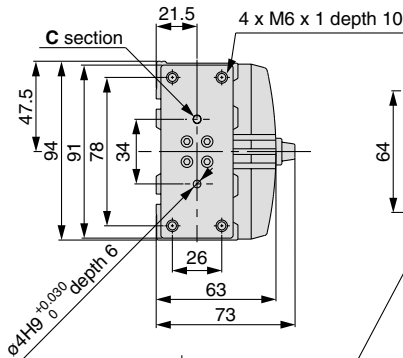
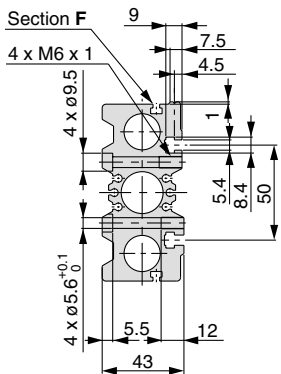

\*\* The dimension inside [ ] shows the location at which the home position switch operates.

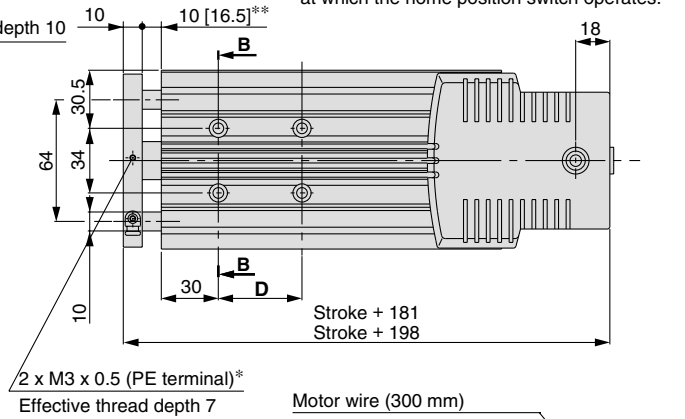

### Cross section BB

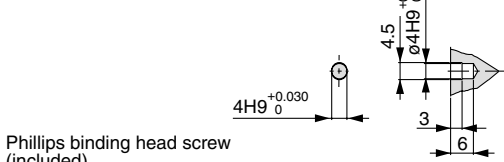

### Section C detail (Scale: 2/1)

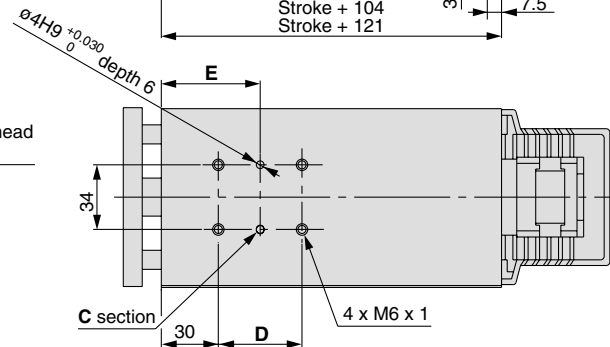
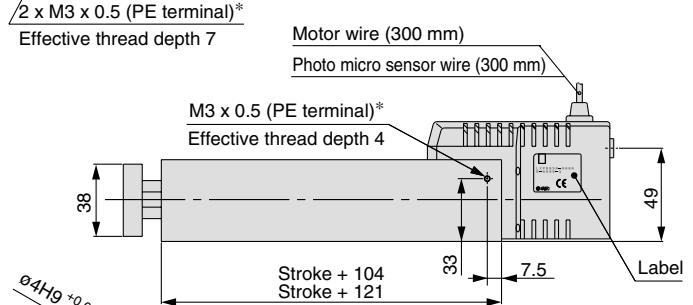
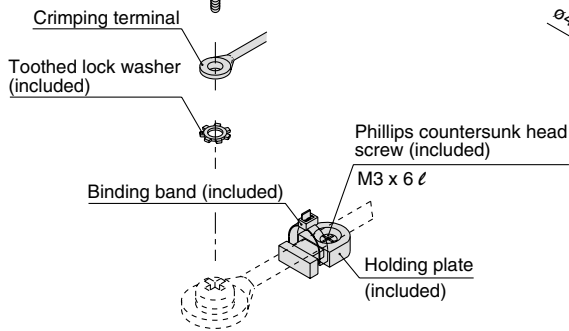

\* When using a PE terminal, use accessories included as shown above.

Model	(mm)	
	D	E
LXPB□S□- 50	44	52
LXPB□S□- 75		
LXPB□S□-100		
LXPB□S□-125	120	90
LXPB□S□-150		
LXPB□S□-175		
LXPB□S□-200		

Refer to page 958 for mounting.



# High Rigidity Slide Table Type With Motor Brake/ **Without** Motor Brake Series **LXS**



## How to Order

### Slide screw specification

**LX S H 2 S B - 100 B - M9N 1 - Q**

#### Actuator configuration

<b>S</b>	Slide table type
----------	------------------

#### Guide type

<b>H</b>	Direct acting guide
----------	---------------------

#### Motor type

<b>2</b>	2 phase stepper motor
<b>5</b>	5 phase stepper motor

#### Lead screw type

<b>S</b>	Slide screw
----------	-------------

#### Lead screw lead

<b>A</b>	6 mm
<b>B</b>	12 mm

#### Stroke

<b>50</b>	50 mm
<b>75</b>	75 mm
<b>100</b>	100 mm
<b>125</b>	125 mm
<b>150</b>	150 mm

Use a driver with CE marking.

#### Home position switch

<b>Nil</b>	None
<b>S</b>	Yes (Cable length 0.3 m)

#### Brake

<b>Nil</b>	Without brake
<b>B</b>	With brake

#### CE marking

#### Number of auto switches/ proximity switches

<b>1</b>	1 pc.
<b>2</b>	2 pcs.
<b>:</b>	<b>:</b>
<b>6</b>	6 pcs.

When using both auto and proximity switches, list the proximity switch part number after the auto switch part number. Example) M9N1G2

#### Auto switch types

Symbol	Model	Wiring/Output type	Lead wire length (m)	Contact
<b>Nil</b>	Without auto switch			
<b>M9N</b>	<b>D-M9N</b>	3 wire/NPN	0.5	N.O. (A contact)
<b>M9P</b>	<b>D-M9P</b>	3 wire/PNP	0.5	N.O. (A contact)
<b>M9B</b>	<b>D-M9B</b>	2 wire	0.5	N.O. (A contact)
<b>F9G</b>	<b>D-F9G</b>	3 wire/NPN	0.5	N.C. (B contact)
<b>F9H</b>	<b>D-F9H</b>	3 wire/PNP	0.5	N.C. (B contact)
<b>F9GL</b>	<b>D-F9GL</b>	3 wire/NPN	3	N.C. (B contact)
<b>F9HL</b>	<b>D-F9HL</b>	3 wire/PNP	3	N.C. (B contact)
<b>M9NL</b>	<b>D-M9NL</b>	3 wire/NPN	3	N.O. (A contact)
<b>M9PL</b>	<b>D-M9PL</b>	3 wire/PNP	3	N.O. (A contact)
<b>M9BL</b>	<b>D-M9BL</b>	2 wire	3	N.O. (A contact)

#### Proximity switch types

Symbol	Model	Wiring/Output type	Lead wire length (m)	Contact
<b>GN</b>	With sensor plate, without proximity switch	—	—	—
<b>G</b>	<b>GX-F8A</b>	3 wire/NPN	1	N.O. (A contact)
<b>GD</b>	<b>GX-F8AI</b>	3 wire/NPN	1	N.O. (A contact)
<b>GB</b>	<b>GX-F8B</b>	3 wire/NPN	1	N.C. (B contact)
<b>GDB</b>	<b>GX-F8BI</b>	3 wire/NPN	1	N.C. (B contact)
<b>GU</b>	<b>GXL-8FU</b>	2 wire/solid state	1	N.O. (A contact)
<b>GUB</b>	<b>GXL-8FUB</b>	2 wire/solid state	1	N.C. (B contact)

\* Refer to page 1082 for detailed specifications of proximity switches.

LJ1

LG1

LTF

LC1

LC7

LXF

LXP

LXS

LC6

LZ

LC3F2

X

D-

E-MY

# Series LXS

## Specifications

<b>Motor</b>		2 phase stepper motor (with/without brake)		5 phase stepper motor (with/without brake)	
<b>Lead screw (mm)</b>		Slide screw ø8 mm			
<b>Positioning repeatability (mm)</b>		±0.05			
<b>Lead (mm)</b>		6	12	6	12
<b>Speed (mm/s)</b> <small>Note 1)</small>		3 to 100	6 to 200	3 to 100	6 to 200
<b>Work load (kg)</b> <small>Note 2)</small>	<b>Horizontal</b>	9 (4)	4.5 (4)	6 (4)	3 (3)
	<b>Vertical</b>	4 (4)	2 (2)	2 (2)	1 (1)
<b>Guide type</b>		High rigidity direct acting guide			
<b>Operating temperature range (°C)</b>		5 to 40 (No condensation)			
<b>Home position switch (optional)</b>		Photo micro sensor EE-SX673 (Refer to page 1084 for details.)			
<b>Brake specifications</b>	<b>Model</b>	De-energized operating type			
	<b>Static torque (N·m)</b>	0.1			
	<b>Rated voltage (V [DC])</b>	24 ±5%			
	<b>Power consumption (W)</b>	5 (at 75°C)			
<b>Applicable driver</b>		LC6D-220AD-Q (Refer to page 964 for details.)		LC6D-507AD-Q (Refer to page 964 for details.)	
<b>Positioning repeatability (mm)</b>		±0.05			
<b>CE marking accessories</b>		Holding plate: MB1 (1 pc.), Phillips countersunk head screw: M3 x 6 ℓ (1 pc.) Phillips binding head screw: M3 x 4 ℓ (2 pcs.), Toothed lock washer M3 (2 pcs.) Binding band: T18S (1 pc.)			

Note 1) Since vibration may increase with low speed operation, set the driver to be driven in half-step mode, and use 6 mm/s or more for 6 mm lead, and 12 mm/s or more for 12 mm lead as a guide for speed.

Note 2) When mounting a work piece to the actuator's end plate, its mass should be within the value inside ( ).

## Mass

Model	Standard stroke (mm)					Additional mass with motor
	50	75	100	125	150	With brake
LXSH <sub>5</sub> S	1.9	2.1	2.3	2.5	2.7	0.2

For basic specifications such as allowable moment, refer to the "Standard" pages for equivalent products listed on Features pages 462 and 463.

# High Rigidity Slide Table Type With Motor Brake/ **Without** Motor Brake Series *LXS*



## How to Order

### Ball screw specification

**LX S H 2 B C - 100 [ ] B - M9N 1 - Q**

#### Actuator configuration

<b>S</b>	Slide table type
----------	------------------

#### Guide type

<b>H</b>	Direct acting guide
----------	---------------------

#### Motor type

<b>2</b>	2 phase stepper motor
<b>5</b>	5 phase stepper motor

#### Lead screw type

<b>B</b>	Ball screw
----------	------------

#### Lead screw lead

<b>C</b>	2 mm
<b>D</b>	5 mm

#### Stroke

<b>50</b>	50 mm
<b>75</b>	75 mm
<b>100</b>	100 mm
<b>125</b>	125 mm
<b>150</b>	150 mm

Use a driver with CE marking.

#### Home position switch

<b>Nil</b>	None
<b>S</b>	Yes (Cable length 0.3 m)

#### Brake

<b>Nil</b>	Without brake
<b>B</b>	With brake

#### CE marking

#### Number of auto switches/ proximity switches

<b>1</b>	1 pc.
<b>2</b>	2 pcs.
<b>:</b>	<b>:</b>
<b>6</b>	6 pcs.

When using both auto and proximity switches, list the proximity switch part number after the auto switch part number.  
Example) M9N1G2

#### Auto switch types

Symbol	Model	Wiring/Output type	Lead wire length (m)	Contact
<b>Nil</b>	Without auto switch			
<b>M9N</b>	<b>D-M9N</b>	3 wire/NPN	0.5	N.O. (A contact)
<b>M9P</b>	<b>D-M9P</b>	3 wire/PNP	0.5	N.O. (A contact)
<b>M9B</b>	<b>D-M9B</b>	2 wire	0.5	N.O. (A contact)
<b>F9G</b>	<b>D-F9G</b>	3 wire/NPN	0.5	N.C. (B contact)
<b>F9H</b>	<b>D-F9H</b>	3 wire/PNP	0.5	N.C. (B contact)
<b>F9GL</b>	<b>D-F9GL</b>	3 wire/NPN	3	N.C. (B contact)
<b>F9HL</b>	<b>D-F9HL</b>	3 wire/PNP	3	N.C. (B contact)
<b>M9NL</b>	<b>D-M9NL</b>	3 wire/NPN	3	N.O. (A contact)
<b>M9PL</b>	<b>D-M9PL</b>	3 wire/PNP	3	N.O. (A contact)
<b>M9BL</b>	<b>D-M9BL</b>	2 wire	3	N.O. (A contact)

#### Proximity switch types

Symbol	Model	Wiring/Output type	Lead wire length (m)	Contact
<b>GN</b>	With sensor plate, without proximity switch	—	—	—
<b>G</b>	<b>GX-F8A</b>	3 wire/NPN	1	N.O. (A contact)
<b>GD</b>	<b>GX-F8AI</b>	3 wire/NPN	1	N.O. (A contact)
<b>GB</b>	<b>GX-F8B</b>	3 wire/NPN	1	N.C. (B contact)
<b>GDB</b>	<b>GX-F8BI</b>	3 wire/NPN	1	N.C. (B contact)
<b>GU</b>	<b>GXL-8FU</b>	2 wire/solid state	1	N.O. (A contact)
<b>GUB</b>	<b>GXL-8FUB</b>	2 wire/solid state	1	N.C. (B contact)

\* Refer to page 1082 for detailed specifications of proximity switches.

LJ1

LG1

LTF

LC1

LC7

LXF

LXP

LXS

LC6

LZ

LC3F2

X

D-

E-MY

# Series LXS

## Specifications

<b>Motor</b>		2 phase stepper motor (with/without brake)		5 phase stepper motor (with/without brake)	
<b>Lead screw (mm)</b>		Ball screw ø8 mm			
<b>Positioning repeatability (mm)</b>		±0.03			
<b>Lead (mm)</b>		2	5	2	5
<b>Speed (mm/s)</b> <small>Note 1)</small>		2 to 30	5 to 80	2 to 30	5 to 80
<b>Work load (kg)</b> <small>Note 2)</small>	<b>Horizontal</b>	9 (4)	4.5 (4)	6 (4)	3 (3)
	<b>Vertical</b>	4 (4)	2 (2)	2 (2)	1 (1)
<b>Guide type</b>		High rigidity direct acting guide			
<b>Operating temperature range (°C)</b>		5 to 40 (No condensation)			
<b>Home position switch (optional)</b>		Photo micro sensor EE-SX673 (Refer to page 1084 for details.)			
<b>Brake specifications</b>	<b>Model</b>	De-energized operating type			
	<b>Static torque (N·m)</b>	0.1			
	<b>Rated voltage (V [DC])</b>	24 ±5%			
	<b>Power consumption (W)</b>	5 (at 75°C)			
<b>Applicable driver</b>		LC6D-220AD-Q (Refer to page 964 for details.)		LC6D-507AD-Q (Refer to page 964 for details.)	
<b>Positioning repeatability (mm)</b>		±0.05			
<b>CE marking accessories</b>		Holding plate: MB1 (1 pc.), Phillips countersunk head screw: M3 x 6 ℓ (1 pc.) Phillips binding head screw: M3 x 4 ℓ (2 pcs.), Toothed lock washer M3 (2 pcs.) Binding band: T18S (1 pc.)			

Note 1) Since vibration may increase with low speed operation, set the driver to be driven in half-step mode, and use 2 mm/s or more for 2 mm lead, and 5 mm/s or more for 5 mm lead as a guide for speed.

Note 2) When mounting a work piece to the actuator's end plate, its mass should be within the value inside ( ).

## Mass

Model	Standard stroke (mm)					Additional mass with motor
	50	75	100	125	150	With brake
LXSH <sub>5</sub> S	1.9	2.1	2.3	2.5	2.7	0.2

For basic specifications such as allowable moment, refer to the "Standard" pages for equivalent products listed on Features pages 462 and 463.

# High Rigidity Slide Table Type With Motor Brake/Without Motor Brake **Series LXS**

## Dimensions/LXSH<sub>5</sub><sup>2</sup>

### With brake

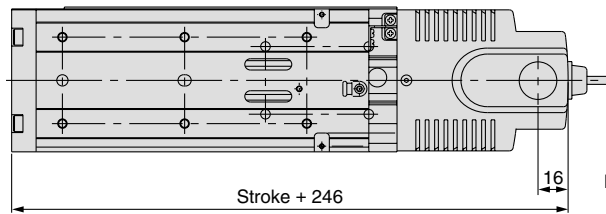

### Brake electrical circuit

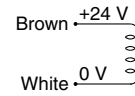

Note) A contact protection circuit is required when connecting a brake.

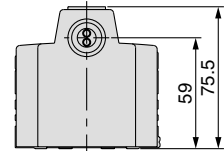
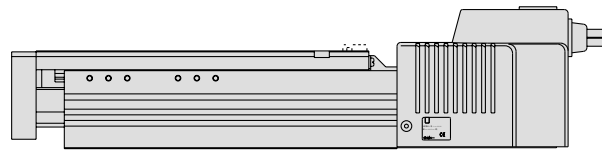
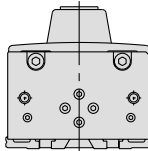

### Without brake

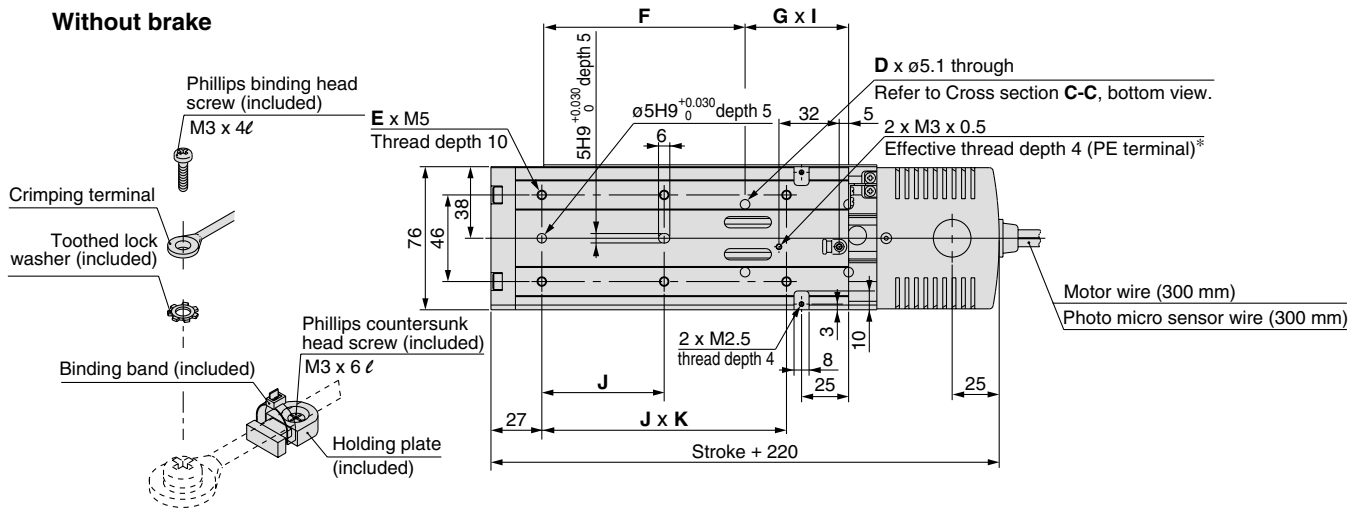

\* When using a PE terminal, use accessories included as shown above.

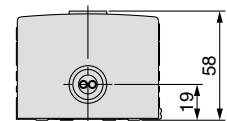
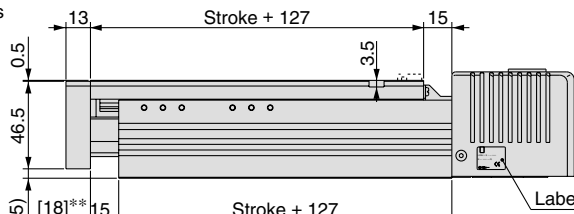
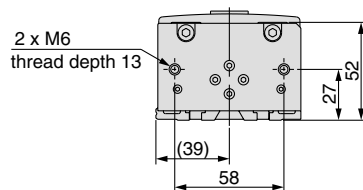

\*\* The dimension inside [ ] shows the location at which the home position switch operates.

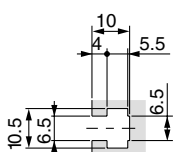

T-slot A dimension

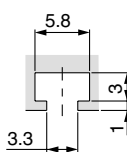

T-slot B dimension

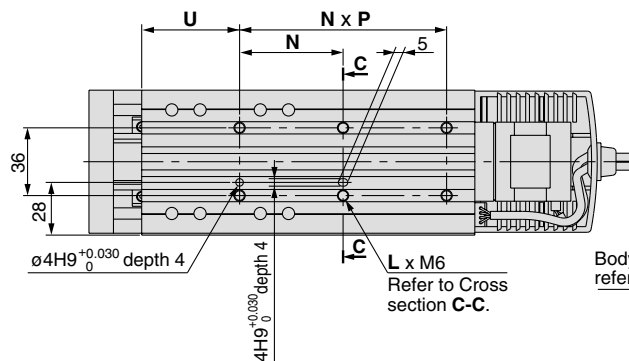

L x M6 Refer to Cross section C-C.

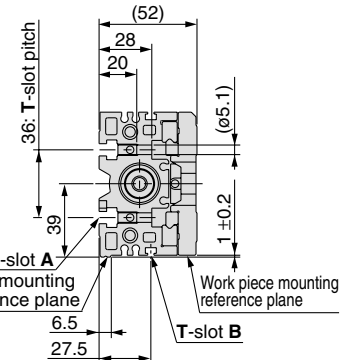

(mm) **Cross Section C-C**

Model	D	E	F	G	I	J	K	L	N	P	U
LXSH□S□- 50□	4	6	107	55	1	65	2	6	55	2	52
LXSH□S□- 75□	4	6	112	65	1	75	2	6	65	2	47
LXSH□S□-100□	4	8	122	75	1	65	3	6	75	2	47
LXSH□S□-125□	4	8	132	85	1	70	3	6	85	2	47
LXSH□S□-150□	6	8	112	65	2	75	3	8	65	3	47

Refer to page 959 for mounting.

- LJ1
- LG1
- LTF
- LC1
- LC7
- LC8
- LXF
- LXP
- LXS**
- LC6□
- LZ□
- LC3F2
- X□
- D-□
- E-MY

# Series LX Construction

## Construction

## Series LXF

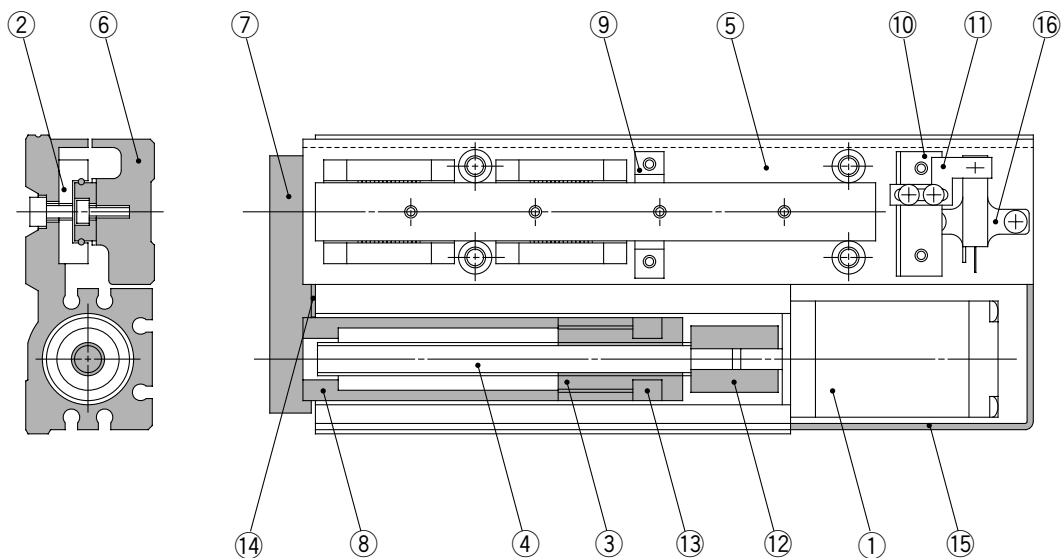

### Parts list

No.	Description	Material	Note
1	Motor	—	
2	Direct acting guide	—	
3	Nut	Resin/Alloy steel	
4	Rolled screw	Alloy steel	
5	Body	Aluminum alloy	Anodized
6	Table	Aluminum alloy	Anodized
7	End plate	Aluminum alloy	Anodized
8	Tube	Aluminum alloy	Anodized
9	Stopper A	—	

### Parts list

No.	Description	Material	Note
10	Stopper B	Aluminum alloy	
11	Sensor plate	Mild steel	Chromated
12	Coupling	Aluminum alloy	
13	Magnet	—	
14	Bumper	Rubber	
15	Motor cover	Resin	
16	Photo micro sensor	—	

**Construction**

**Series LXP**

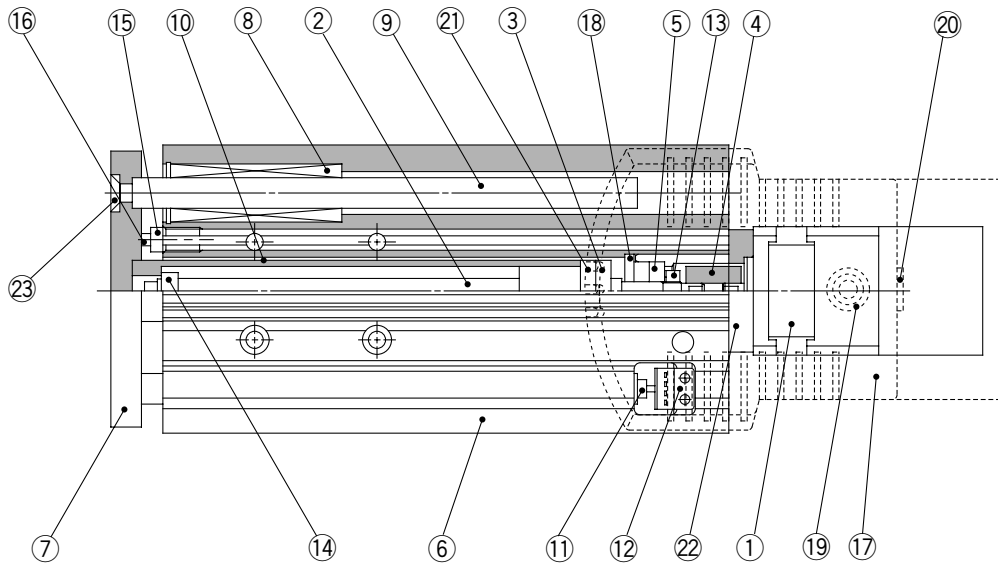

- LJ1
- LG1
- LTF
- LC1
- LC7
- LC8
- LXF**
- LXP**
- LXS
- LC6□
- LZ□
- LC3F2
- X□
- D-□
- E-MY

**Parts list**

No.	Description	Material	Note
1	Motor	—	Stepper motor
2	Rolled screw	Alloy steel	
3	Nut	Resin	
4	Coupling	—	
5	Bearing	—	
6	Body	Aluminum alloy	Anodized
7	Mounting plate	Mild steel	Nickel plated
8	Ball bushing	—	
9	Guide rod	Bearing steel	Chrome plated
10	Tube	Aluminum alloy	Anodized
11	Sensor pin	Stainless steel	

**Parts list**

No.	Description	Material	Note
12	Photo micro sensor	—	
13	Lock nut	Carbon steel	Black zinc chromated
14	Stopper nut	Aluminum alloy	
15	Bumper bolt	Bearing steel	Nickel plated
16	Bumper	Resin	
17	Motor cover	Resin	
18	Tension ring	Stainless steel	
19	Cable cap		
20	Plug		
21	Magnet	—	
22	Adaptor	Aluminum alloy	
23	Plate mounting bolt	Carbon steel	Nickel plated

# Series LX

## Construction

# Series LXS

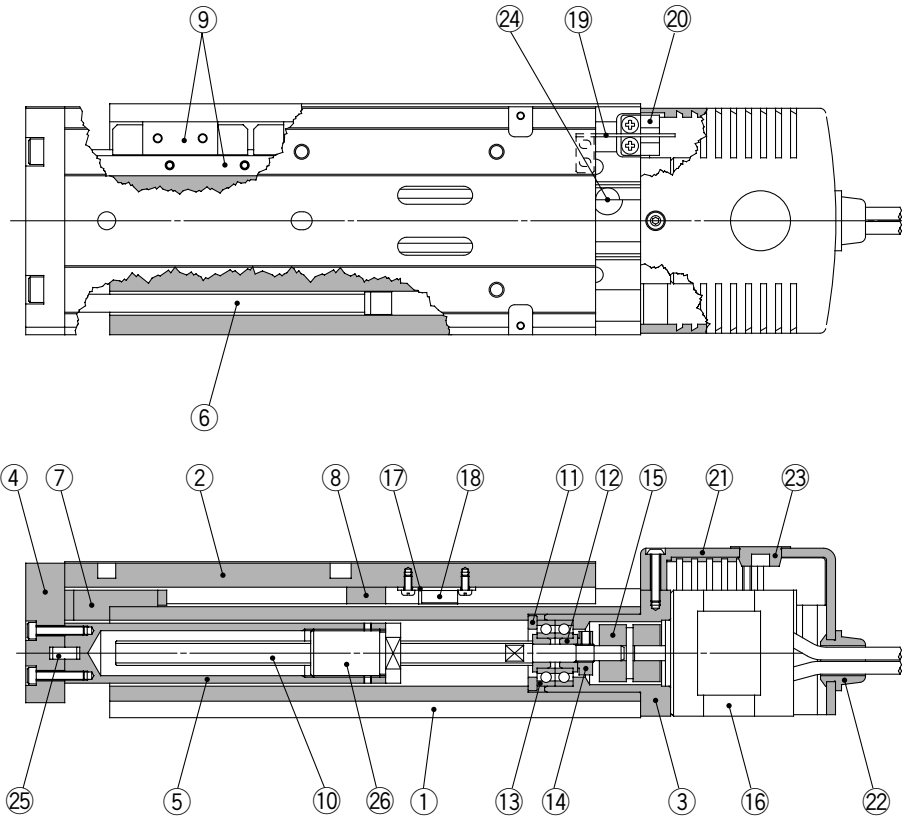

### Parts list

No.	Description	Material	Note
1	Body	Aluminum alloy	Anodized
2	Table	Aluminum alloy	Anodized
3	Adaptor	Aluminum alloy	Anodized
4	Plate	Aluminum alloy	Anodized
5	Tube	Aluminum alloy	Anodized
6	Rod assembly	—	With magnet
7	Stopper A	—	With bumper
8	Stopper B	—	
9	Direct acting guide (block, rail)	—	
10	Rolled screw (shaft only)	Alloy steel	
11	Tension ring	Stainless steel	
12	Bearing retainer	Stainless steel	
13	Bearing	—	

### Parts list

No.	Description	Material	Note
14	Lock nut	Carbon steel	Black zinc chromated
15	Coupling	—	
16	Motor	—	
17	Magnet holder	Resin	
18	Magnet	—	
19	Sensor plate	Mild steel	With home position switch
20	Photo micro sensor	—	With home position switch
21	Motor cover	Resin	
22	Plug A		
23	Plug B		
24	Cap		
25	Parallel pin	Carbon steel	
26	Nut	Resin/Alloy steel	



# Series LX Mounting

## Mounting

### Series LXF

#### Actuator mounting

An actuator can be mounted from two directions, which can be selected depending on the equipment or work piece.

1. Tapped holes			
Model	Bolt	Max. tightening torque (N·m)	Max. screw-in depth (ℓ mm)
LXF	M5 x 0.8	4.4	8

**Caution** Use bolts at least 0.5 mm shorter than the maximum screw-in depth, so they do not touch the body.

2. Through holes			
Model	Bolt	Max. tightening torque (N·m)	Body thickness (ℓ mm)
LXF	M4 x 0.7	2.1	8

#### Work piece mounting

Work pieces can be mounted on two sides of the actuator.

1. Front mount type			
Model	Bolt	Max. tightening torque (N·m)	Body thickness (ℓ mm)
LXF	M4 x 0.7	2.1	10

2. Top mount type			
Model	Bolt	Max. tightening torque (N·m)	Max. screw-in depth (ℓ mm)
LXF	M4 x 0.7	2.1	8

**Caution** Use bolts at least 0.5 mm shorter than the maximum screw-in depth, so they do not touch the body.

LJ1

LG1

LTF

LC1

LC7

LC8

LXF

LXP

LXS

LC6□

LZ□

LC3F2

X□

D-□

E-MY

# Series LX

## Mounting

### Series LXP

#### Actuator mounting

##### 1. Tapped holes

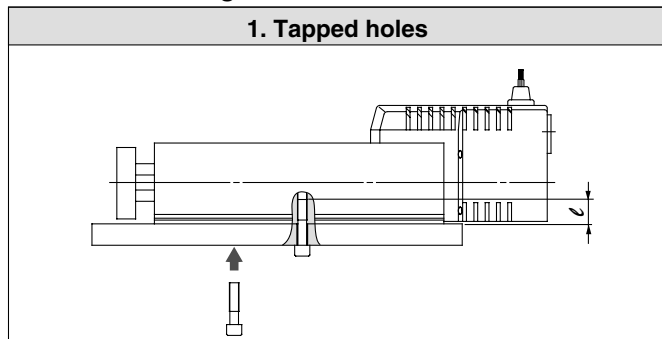

Model	Bolt	Max. tightening torque (N·m)	Max. screw-in depth (ℓ mm)
LXP	M6 x 1	7.4	12

##### 2. Through holes

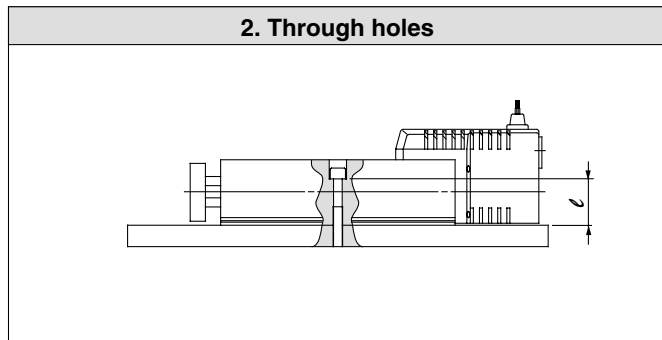

Model	Bolt	Max. tightening torque (N·m)	Body thickness (ℓ mm)
LXP	M5 x 0.8	4.4	37.5

##### 3. T-slots

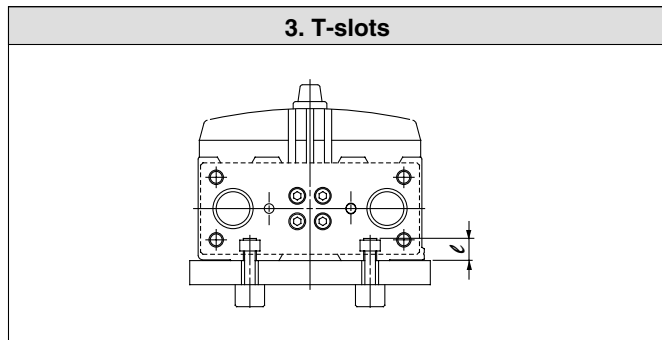

Model	Bolt	Max. tightening torque (N·m)	Max. screw-in depth (ℓ mm)
LXP	M5 x 0.8	7.4	8.5

**⚠ Caution** Use bolts at least 0.5 mm shorter than the maximum screw-in depth, so they do not touch the body.

#### Work piece mounting

##### 1. Front mount type

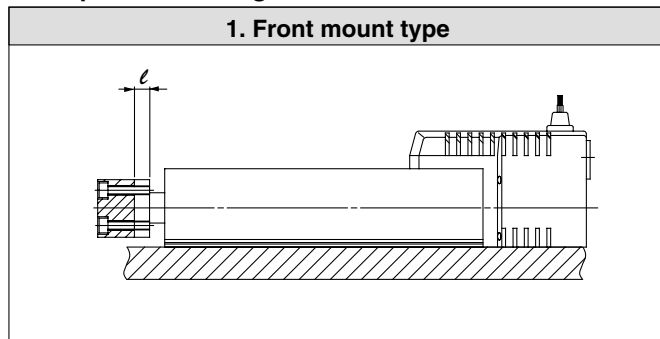

Model	Bolt	Max. tightening torque (N·m)	Max. screw-in depth (ℓ mm)
LXP	M6 x 1	7.4	10

## Mounting

### Series LXS

#### Actuator mounting

An actuator can be mounted in any of 3 ways, which can be selected depending on the equipment or work piece.

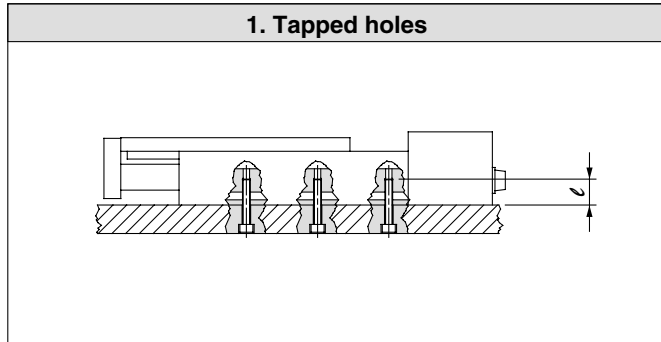

Model	Bolt	Max. tightening torque (N·m)	Max. screw-in depth (ℓ mm)
LXS	M6 x 1	7.4	20

**Caution** Use bolts at least 0.5 mm shorter than the maximum screw-in depth, so they do not touch the body.

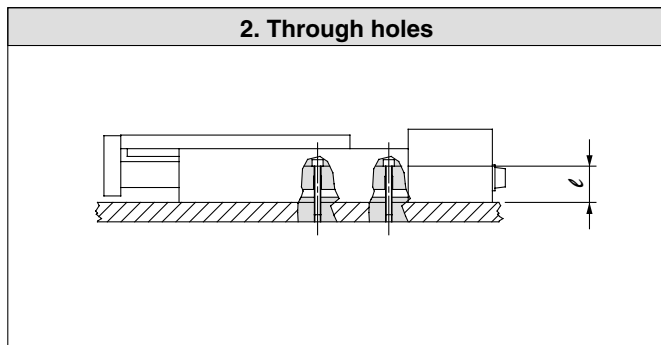

Model	Bolt	Max. tightening torque N·m	Body thickness (ℓ mm)
LXS	M5 x 0.8	4.4	28

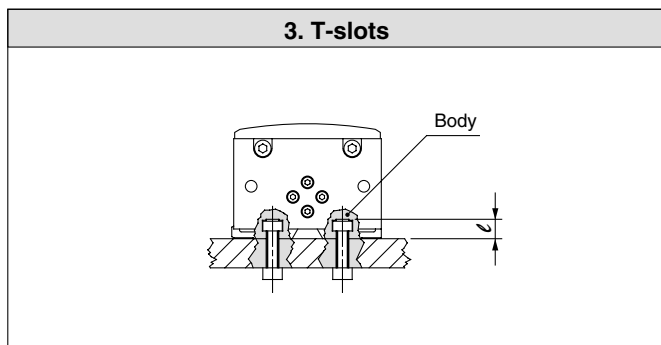

Model	Bolt	Max. tightening torque (N·m)	Max. screw-in depth (ℓ mm)
LXS	M6 x 1	7.4	10

**Caution** Use bolts at least 0.5 mm shorter than the maximum screw-in depth, so they do not touch the body.

#### Work piece mounting

Work pieces can be mounted on two sides of the actuator.

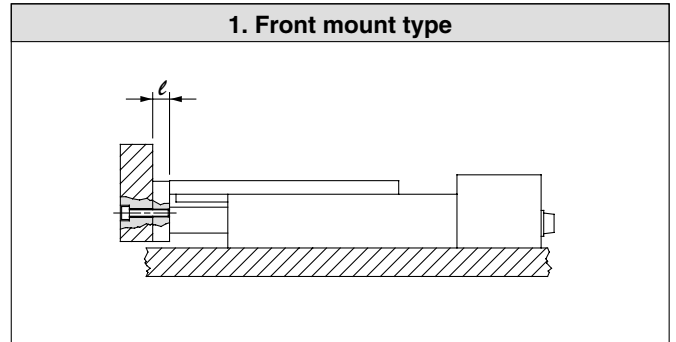

Model	Bolt	Max. tightening torque (N·m)	Max. screw-in depth (ℓ mm)
LXS	M6 x 1	7.4	13

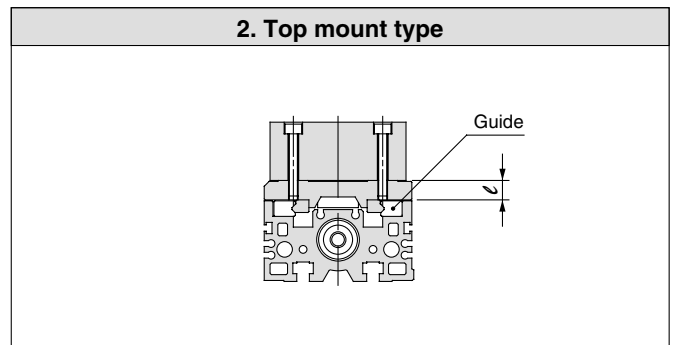

Model	Bolt	Max. tightening torque (N·m)	Max. screw-in depth (ℓ mm)
LXS	M5 x 0.8	4.4	10

**Caution** Use bolts at least 0.5mm shorter than the maximum screw-in depth, so they do not touch the body.

LJ1

LG1

LTF

LC1

LC7

LC8

LXF

LXP

LXS

LC6□

LZ□

LC3F2

X□

D-□

E-MY

# Acceleration Time Guide

## Acceleration Time Guide/Slide Screw Specification (Horizontal)

### LXFH5SA

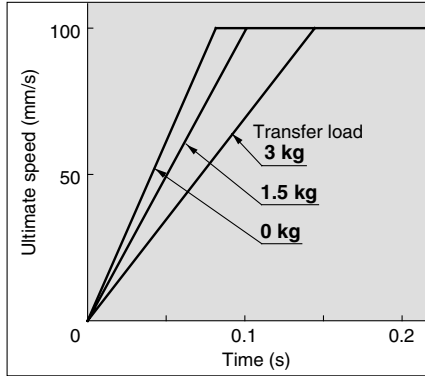

### LXPB2SA/LXSH2SA

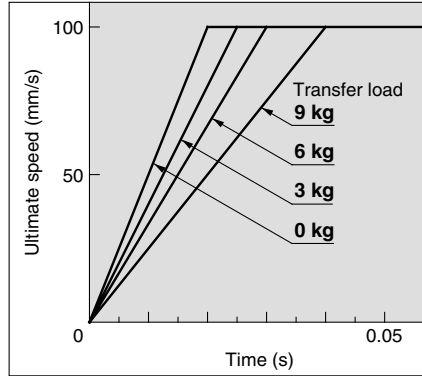

### LXPB5SA/LXSH5SA

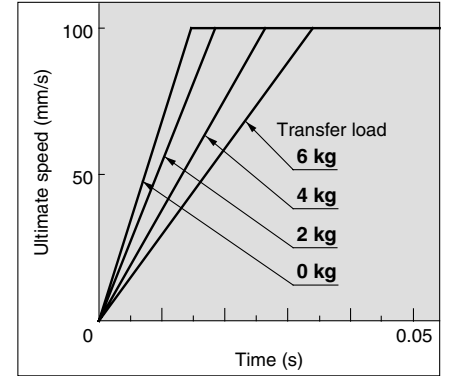

### LXFH5SB

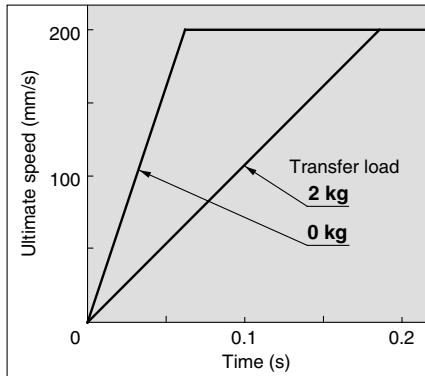

### LXPB2SB/LXSH2SB

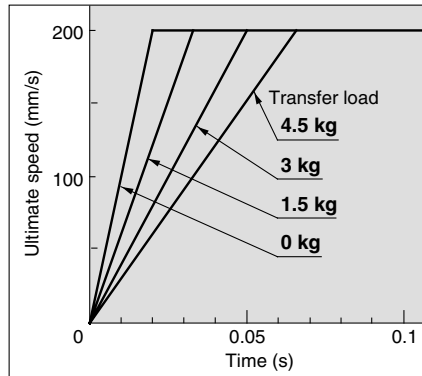

### LXPB5SB/LXSH5SB

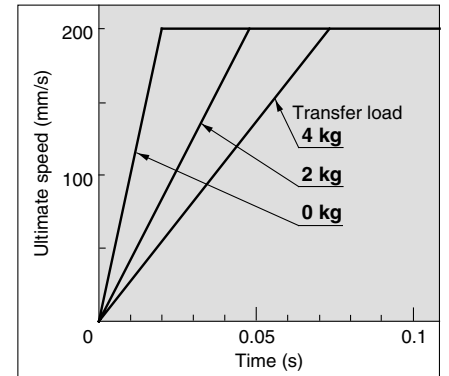

## Acceleration Time Guide/Slide Screw Specification (Vertical)

### LXPB2SA/LXSH2SA

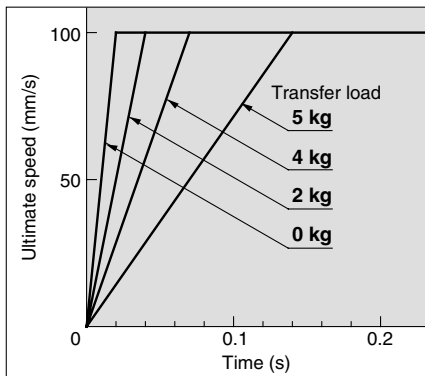

### LXPB5SA/LXSH5SA

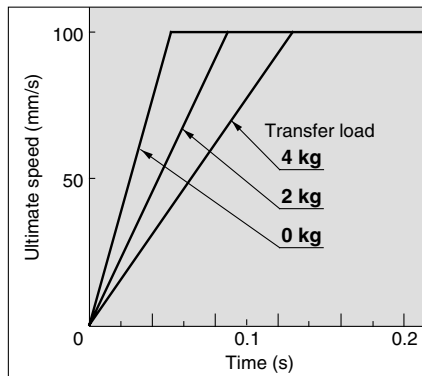

### LXPB2SB/LXSH2SB

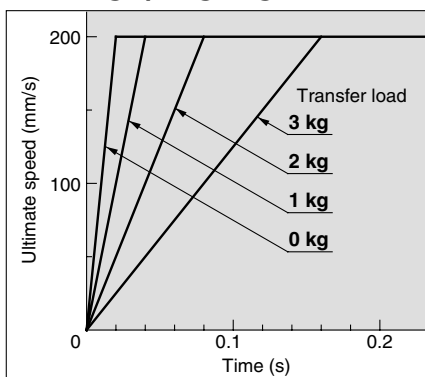

### LXPB5SB/LXSH5SB

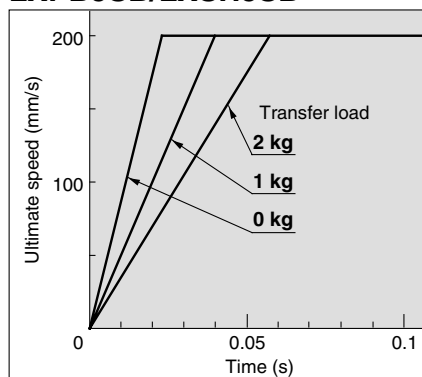

## ⚠ Caution

- Transfer loads should not exceed each model's work load specification.
- Determine the acceleration time based on the transfer load and ultimate speed.
- Operating over the graph ranges will cause loss of synchronism.
- The graphs are based on operation using an SMC DC power input type driver with halfstep energization.
- Data fluctuate depending on the operating conditions.

**Acceleration Time Guide/Ball Screw Specification (Horizontal)**

**LXFH5BC**

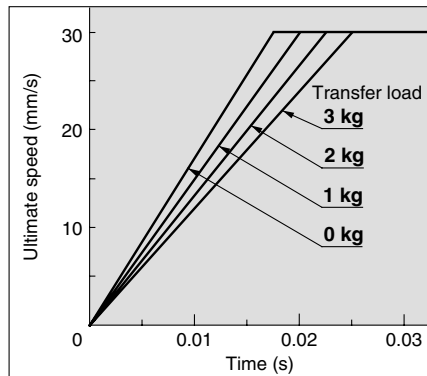

**LXPB2BC/LXSH2BC**

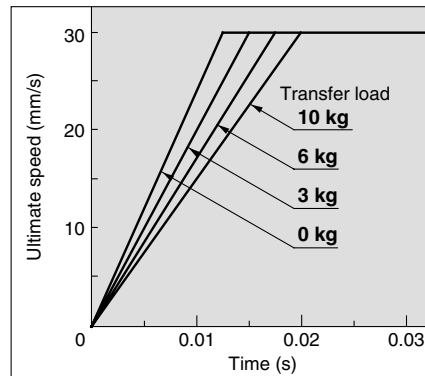

**LXPB5BC/LXSH5BC**

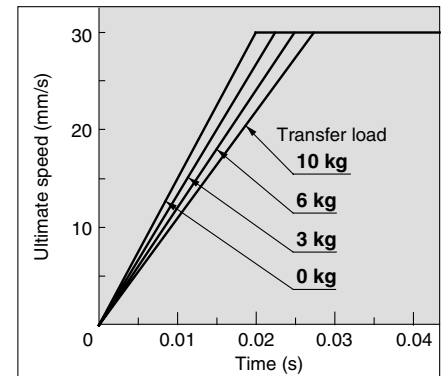

**LXFH5BD**

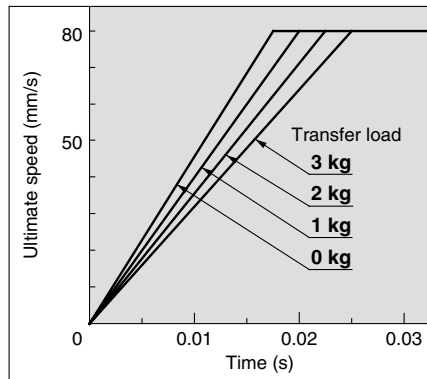

**LXPB2BD/LXSH2BD**

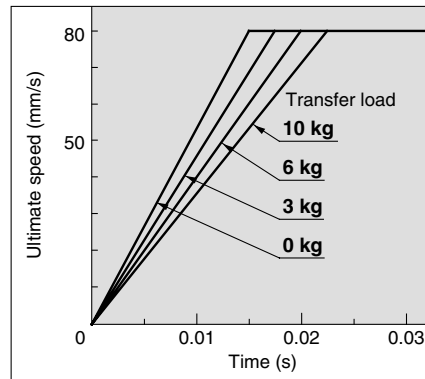

**LXPB5BD/LXSH5BD**

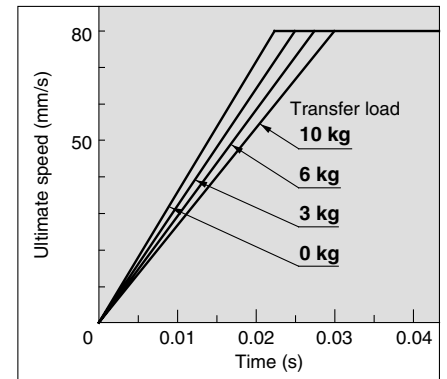

**Acceleration Time Guide/Ball Screw Specification (Vertical)**

**LXPB2BC/LXSH2BC**

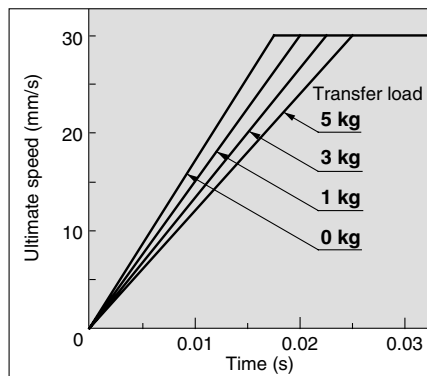

**LXPB5BC/LXSH5BC**

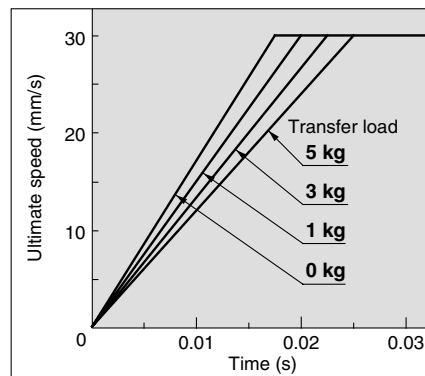

**LXPB2BD/LXSH2BD**

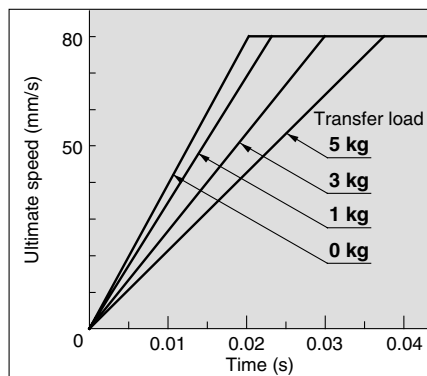

**LXPB5BD/LXSH5BD**

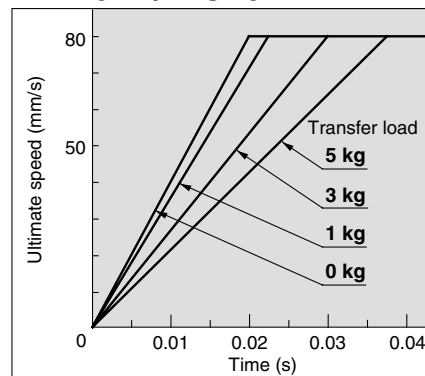

**⚠ Caution**

- Transfer loads should not exceed each model's work load specification.
- Determine the acceleration time based on the transfer load and ultimate speed.
- Operating over the graph ranges will cause loss of synchronism.
- The graphs are based on operation using an SMC DC power input type driver with halfstep energization.
- Data fluctuate depending on the operating conditions.

LJ1

LG1

LTF

LC1

LC7

LC8

LXF

LXP

LXS

LC6

LZ

LC3F2







X

D-

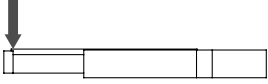
E-MY

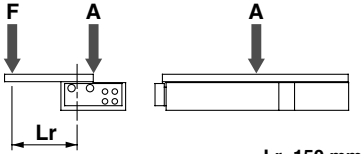
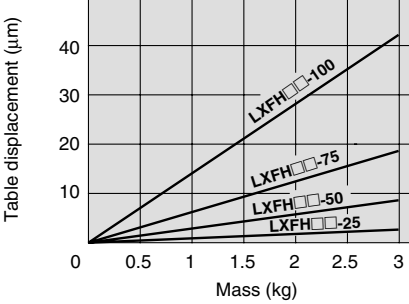
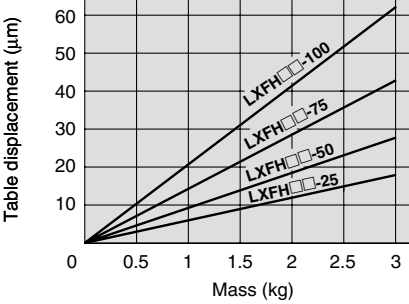
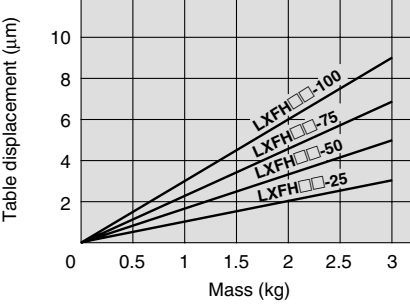
# Series LX Table Deflection

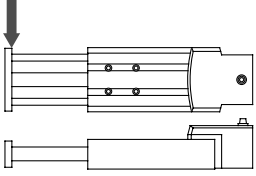
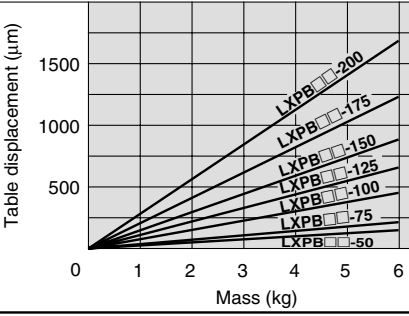
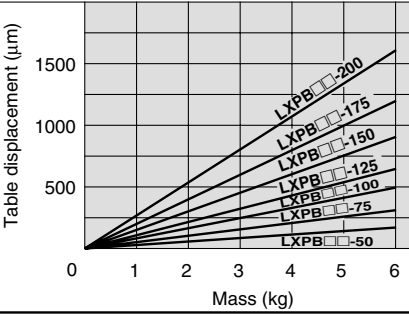
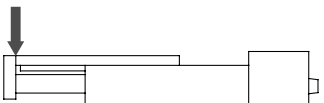
## Table Deflection

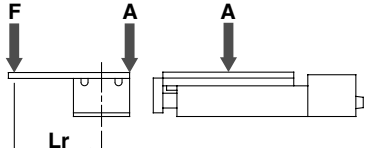
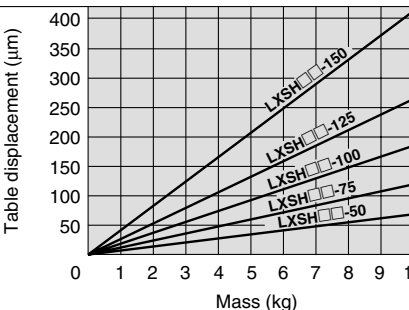
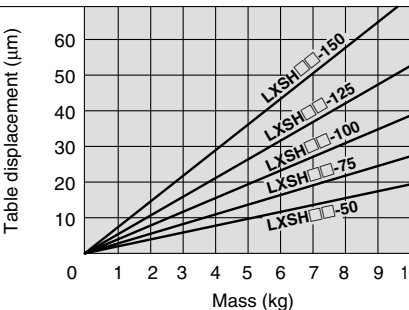
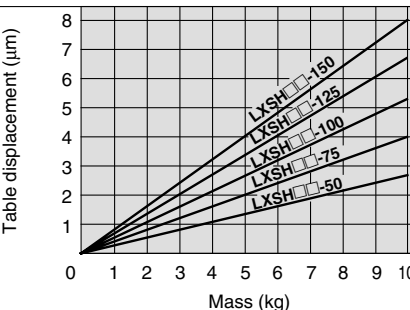
	Table displacement by pitch moment load	Table displacement by yaw moment load	Table displacement by roll moment load
<b>LXF</b>	<p>Displacement at the section indicated by the arrow when a load is applied to this section with the slide table fully extended.</p> 	<p>Displacement at the section indicated by the arrow when a load is applied to this section with the slide table fully extended.</p> 	<p>Displacement at "A" when a load is applied to "F" with the slide table retracted.</p>  <p style="text-align: right;"><b>Lr=150 mm</b></p>
	<p>Table displacement (<math>\mu\text{m}</math>)</p>  <p style="text-align: center;">Mass (kg)</p>	<p>Table displacement (<math>\mu\text{m}</math>)</p>  <p style="text-align: center;">Mass (kg)</p>	<p>Table displacement (<math>\mu\text{m}</math>)</p>  <p style="text-align: center;">Mass (kg)</p>
<b>LXPB</b>	<p>Displacement at the section indicated by the arrow when a load is applied to this section with the electric actuator fully extended.</p> 	<p>Displacement at the section indicated by the arrow when a load is applied to this section with the electric actuator fully extended.</p> 	
	<p>Table displacement (<math>\mu\text{m}</math>)</p>  <p style="text-align: center;">Mass (kg)</p>	<p>Table displacement (<math>\mu\text{m}</math>)</p>  <p style="text-align: center;">Mass (kg)</p>	
<b>LXSH</b>	<p>Displacement at the section indicated by the arrow when a load is applied to this section with the slide table fully extended.</p> 	<p>Displacement at the section indicated by the arrow when a load is applied to this section with the slide table fully extended.</p> 	<p>Displacement at "A" when a load is applied to "F" with the slide table retracted.</p>  <p style="text-align: right;"><b>Lr=200 mm</b></p>
	<p>Table displacement (<math>\mu\text{m}</math>)</p>  <p style="text-align: center;">Mass (kg)</p>	<p>Table displacement (<math>\mu\text{m}</math>)</p>  <p style="text-align: center;">Mass (kg)</p>	<p>Table displacement (<math>\mu\text{m}</math>)</p>  <p style="text-align: center;">Mass (kg)</p>