

2/3 Port Solenoid Valve for Chemical Liquids

LVM Series

Compact Direct Operated

★ Isolated structure

Diaphragm isolates the solenoid drive body from the fluid.

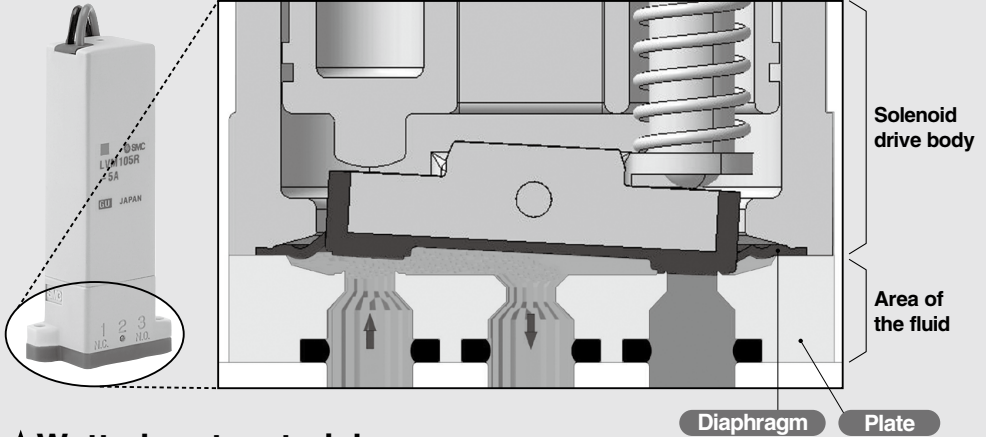

★ Wetted part material (Metal free)

Body/Plate

PEEK

Choice of

Diaphragm

EPDM, FKM, Kalrez[®] (Note)

Highly integrated resin manifold (Made to Order)

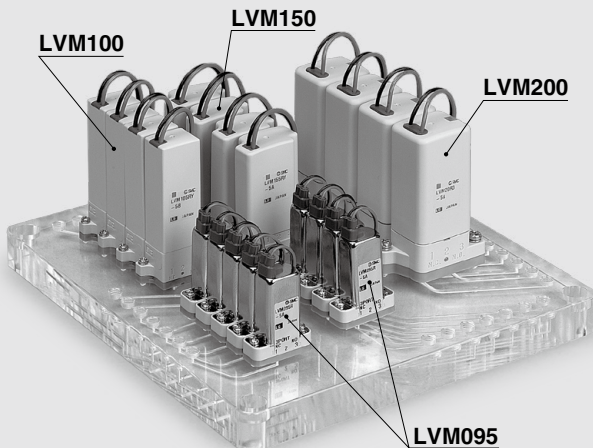

VCH □

VDW

SX10

VQ

LVM

Note) Kalrez[®] is a registered trademark of E. I. du Pont de Nemours and Company or its affiliates.

Meeting the most advanced needs of process control

Compact Direct Operated 2/3 Port

○ Valve chamber volume

Unit: μL

Series	LVM09/090	LVM10 (For LVM11)	LVM10/100	LVM15/150	LVM20/200
Valve chamber volume	18	11	20	50	84

○ Change in volume depending on open/closed status of valve (pumping volume)

0.01 μL or less (Rocker type)

"Pumping volume" refers to the volume of water that is expelled from the valve chamber, in which it is sealed, by the opening and closing action of the valve (once with no applied pressure).

With a normal diaphragm valve, because the valve chamber volume varies depending on ON or OFF status, a difference in volume is discharged into the outlet side of the valve when the valve is switched from ON to OFF. However, with a rocker type valve, there is almost no change in volume, and thus no fluid is discharged into the outlet side of the valve.

Diaphragm
valve



Rocker
type



○ Type with power-saving circuit can be selected.

Holding power consumption can be reduced substantially. Continuous energization for extended periods is possible.

Unit: W

Series		LVM09/090	LVM10/100	LVM15/150	LVM20/200
Power consumption	Inrush	3.3	2.5	5.5	4
	Holding	0.9	1	1	0.6

Refer to 10 in "Design and Selection" on the page 553, if the valve is to be energized continuously for extended periods of time, or used with a manifold.

○ Space-saving

Unit: mm

Series	LVM090	LVM10/100	LVM150	LVM200
Valve width	9.5	13	16	20
Manifold pitch	10.5	14	17	21

Valve width

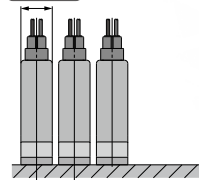

Manifold pitch

Highly integrated resin manifold

Material: Acrylic

(Made to Order)

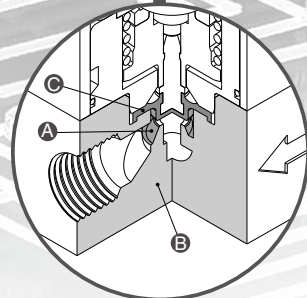
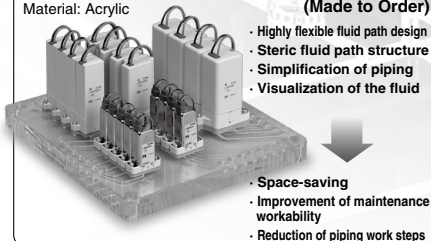

LVM11

○ Applications: Various analytical and inspection equipment

Analytical instruments for blood, urine, immune system, etc.

Solenoid Valve for Chemical Liquids

Piping/Mounting Variations

Body ported

- M5 thread
- Tubing type

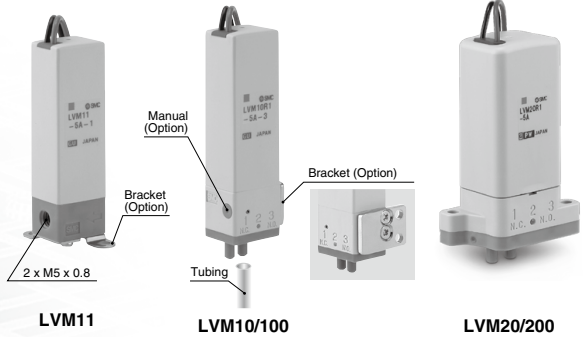

Base mounted

- Without sub-plate

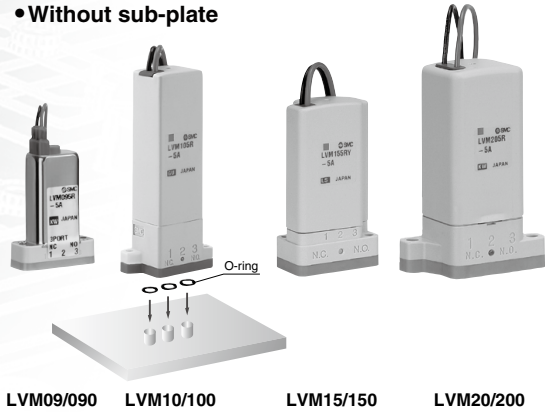

- With sub-plate

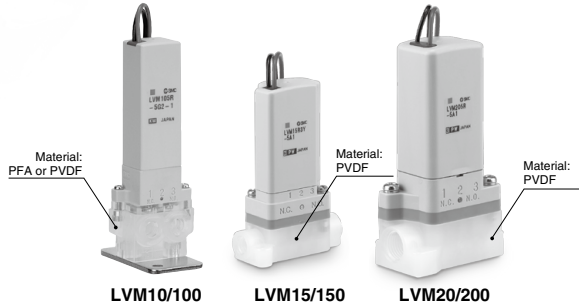

VCH □

VDW

SX10

VQ

LVM

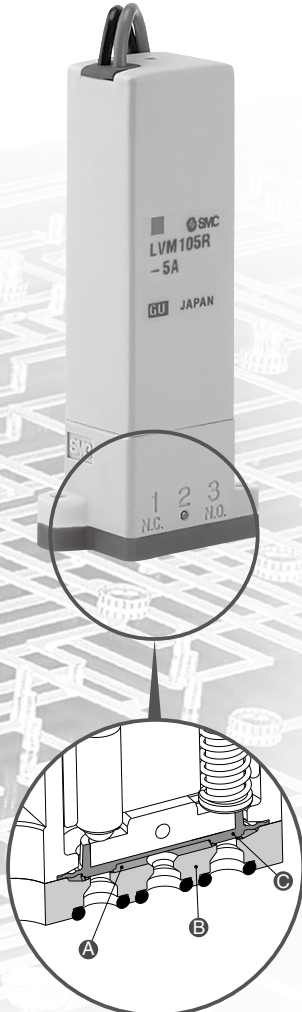

LVM□□□
(Rocker type)

- A** Valve chamber volume
- B** Body/Plate material*: PEEK
- C** Diaphragm material:
EPDM or FKM or Kalrez®

* Plate material PFA can be selected for the LVM10/100 base mounted type.
Kalrez® is a registered trademark of E. I. du Pont de Nemours and Company or its affiliates.

Series Variations

	Model	Valve construction	Valve type	Number of ports	Operating pressure range	Orifice diameter (mm)	Valve width (mm)	
	LVM09R3	Diaphragm type direct operated poppet (Rocker type)	N.C.	2	-75 kPa to 0.2 MPa	1.1	9.5	
	LVM09R4		N.O.					
	LVM095R		Universal	3				
	LVM11	Diaphragm type direct operated poppet	N.C.	2	0 to 0.25 MPa	1.5	13	
	LVM10R1	Diaphragm type direct operated poppet (Rocker type)	N.C.	2	-75 kPa to 0.25 MPa	1.4	13	
	LVM10R2		N.O.					
	LVM102R		Universal	3				
	LVM10R3		N.C.	2	-75 kPa to 0.25 MPa	1.4	13	
	LVM10R4		N.O.					
	LVM10R6		N.C.					
	LVM105R	Universal	3					
	LVM15R3	N.C.	2	-75 kPa to 0.25 MPa (Max. 0.6 MPa)	1.6 (1)	16		
	LVM15R4	N.O.						
	LVM155R	Universal	3					
	LVM20R1	N.C.	2	-75 kPa to 0.25 MPa	2	20		
	LVM20R2	N.O.						
	LVM202R	Universal	3					
	LVM20R3	N.C.	2	-75 kPa to 0.3 MPa	2	20		
	LVM20R4	N.O.						
	LVM205R	Universal	3					

Flow rate characteristics					Fluid temperature (°C)	Volume of valve chamber (μL)	Weight (g)	Power consumption (W)	Page
Water		Air							
Kv[m ²]	Cv	C[dm ³ /(S·bar)]	b						
0.015	0.018	0.06	0.2	0 to 50 (No condensation)	18	20	2	P.532 to 534	
0.034	0.04	0.13	0.22		11	30	2.5 at inrush 1 at holding	P.535 to 539	
0.025	0.03	0.1	0.2		20	34	1.5	P.535 to 541	
0.025	0.03	0.1	0.2		20	34	1.5		
0.034 (0.012)	0.04 (0.015)	0.13 (0.05)	0.22 (0.2)		50	45	5.5 at inrush 1 at holding	P.542 to 545	
0.055	0.065	0.23	0.27		84	80	2.5	P.546 to 550	
0.055	0.065	0.23	0.27		84	80	2.5	P.546 to 552	

VCH

VDW

SX10

VQ

LVM

High-pressure type is indicated in brackets.

* The values of Kv and Cv are based on JIS B 2005:1995, C and b are based on JIB B 8390:2000.

Compact Direct Operated 2/3 Port Solenoid Valve for Chemical Liquids

LVM09/090 Series

How to Order



Base mounted

LVM **09R3** - **5** **A** - -

Symbol	Number of ports	Valve type	
09R3	2	N.C.	
		N.O.	
09R4	2	N.O.	
09R5R	3	Universal	

Series

CE-compliant

Nil	None
Q	CE-compliant

Base mounted
(Without sub-plate)

Lead wire length

Nil	150 mm
3	300 mm
6	600 mm

* Nil cannot be selected in the case of function Y1.

Wetted part material

Symbol	Plate	Diaphragm
A	PEEK	EPDM
B	PEEK	FKM
C	PEEK	Kalrez®

Coil voltage

Symbol	Voltage
5	24 VDC
6	12 VDC

Function

Nil	Standard
Y1	With power-saving circuit

Specifications

Model	Base mounted		
	LVM09R3	LVM09R4	LVM09R5R
Valve construction	Diaphragm type direct operated poppet (Rocker type)		
Valve type	N.C.	N.O.	Universal
Number of ports	2	2	3
Fluid Note 1)	Air, Water, DI water (Pure water), Diluent, Cleaning fluid		
Operating pressure range	-75 kPa to 0.2 MPa		
Orifice diameter	1.1 mm		
Response time Note 8)	10 ms or less (at pneumatic pressure)		
Leakage	Zero leakage, either external or internal (at water pressure)		
Proof pressure Note 2)	0.3 MPa		
Ambient temperature Note 9)	0 to 50°C		
Fluid temperature Note 9)	0 to 50°C (No condensation)		
Volume of valve chamber Note 3)	18 μ L		
Mounting orientation Note 4)	Free		
Enclosure	IP40 or equivalent		
Weight	20 g		
Rated voltage	12, 24 VDC		
Allowable voltage fluctuation Note 5)	\pm 10% of rated voltage		
Type of coil insulation	Class B		
Power consumption (When rated voltage is at 24 V)	Standard	Inrush	2 W (0.08 A)
		Holding	3.3 W (0.14 A)
	With power-saving circuit	Inrush	0.9 W
		Holding	50 dB

Note 1) Select an appropriate material for the wetted part according to the fluid to be used. Additionally, check the chemical resistance beforehand.

Note 2) Indicates the pressure which does not generate breakage, cracks or external leakage after a one-minute airtight test.

Note 3) Indicates the volume of clearance inside the valve chamber after the volume of the diaphragm is subtracted.

Note 4) Since the body (orifice shape) is designed to eliminate residual liquid, mounting in a vertical direction with the coil at the top is recommended. When residual liquid is not considered, any mounting orientation is available.

Note 5) When the response speed is regarded as important, prevent negative fluctuation of the voltage by adequate regulation.

Note 6) The value is based on SMC's measurement conditions. The noise level will vary with conditions.

Note 7) Refer to 10 in "Design and Selection" on the back of page 553, if the valve is to be energized continuously for extended periods of time.

Note 8) In conformity with JIS B8419:2010 (value at ambient and fluid temperature of 25°C, rated voltage, maximum operating pressure (air) and when the N.C. (N) port is pressurized)

The response time may vary depending on the supply pressure, fluid, piping conditions and ambient temperature.

Note 9) When the diaphragm material is Kalrez®, take great care since the valve changeover time becomes significantly long at ambient and fluid temperature of 15°C or less when compared to that at room temperature (-25°C).

Flow Rate Characteristics

Water		Air	
Kv	Cv	C	b
0.015	0.018	0.06	0.2

* The values of Kv and Cv are based on JIS B 2005:1995, C and b are based on JIB B 8390:2000.

Kalrez® is a registered trademark of E. I. du Pont de Nemours and Company or its affiliates.

Construction: Base Mounted

LVM09R3

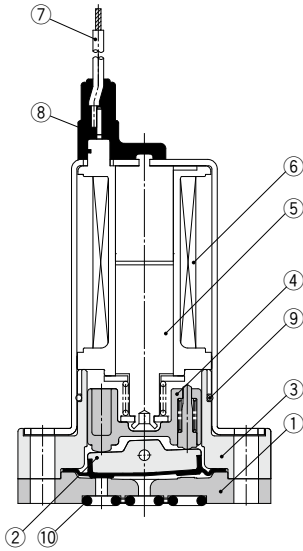

LVM09R4

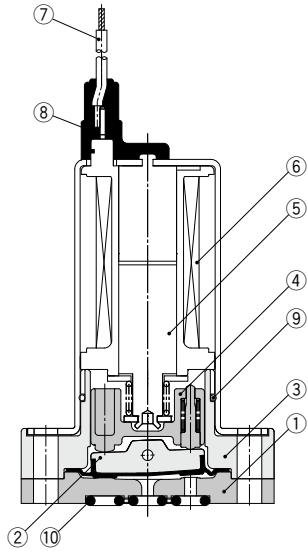

LVM095R

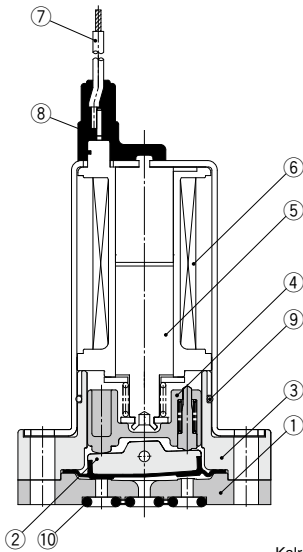

- VCH
- VDW
- SX10
- VQ
- LVM**

Component Parts: LVM09R3, 09R4, 095R

No.	Description	Material
1	Plate	PEEK
2	Diaphragm assembly	EPDM/FKM/Kalrez®
3	Body	PBT
4	Slide bushing assembly	PPS/Stainless steel
5	Armature assembly	—
6	Coil assembly	—
7	Lead wire	—
8	Mold	PET
9	O-ring	NBR
10	Interface gasket	EPDM/FKM/Kalrez®

Kalrez® is a registered trademark of E. I. du Pont de Nemours and Company or its affiliates.

LVM09/090 Series

Dimensions: Base Mounted

LVM09R3-□□-□ (N.C.)

LVM09R4-□□-□ (N.O.)

LVM095R-□□-□ (Universal)

* The broken lines indicate with power-saving circuit.

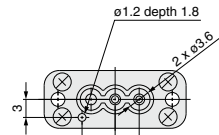
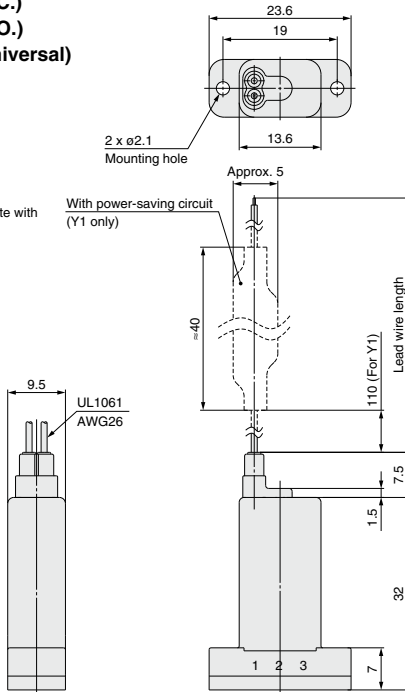

LVM09R4

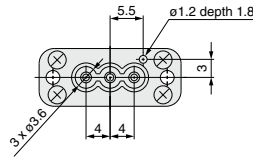

LVM095R

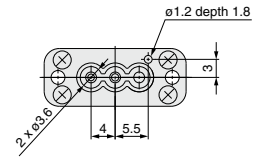

LVM09R3

Recommended interface dimensions

* Surface roughness = Rz3.2 or less

* Surface roughness = Rz3.2 or less

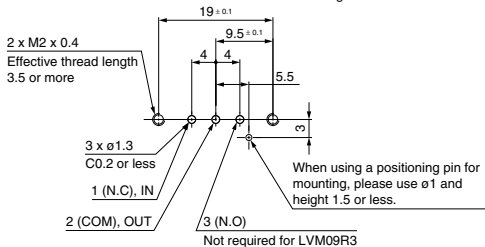

LVM09R3, LVM095R

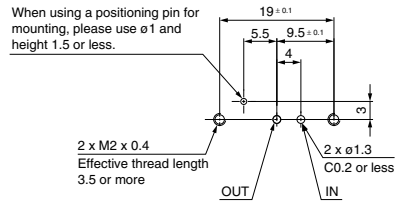

LVM09R4

Compact Direct Operated 2/3 Port Solenoid Valve for Chemical Liquids

LVM10/100 Series



How to Order

Symbol	Number of ports	Valve type		Connection
11		N.C.		M5 thread
10R1	2	N.C.		Tubing type
10R2		N.O.		
102R	3	Universal		

Wetted part material

Symbol	Plate	Diaphragm
A	PEEK	EPDM
B	PEEK	FKM
C	PEEK	Kalrez®

Option

Nil	None
1	Bracket
2	Manual override
3	Bracket, Manual override

* Only Option 1 can be selected for the LVM11

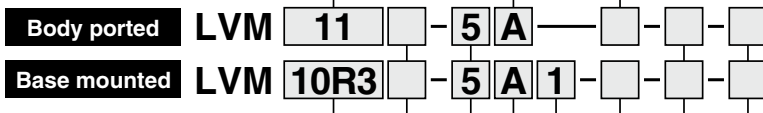

Symbol	Number of ports	Valve type	
10R3		N.C.	
10R4	2	N.O.	
10R6		N.C.	
105R	3	Universal	

Series

Function

Nil	Standard
Y	With power-saving circuit

* For the LVM11, the type with power-saving circuit is standard.

Coil voltage

Symbol	Voltage
5	24 VDC
6	12 VDC

Wetted part material

Symbol	Plate	Diaphragm
A	PEEK	EPDM
B	PEEK	FKM
C	PEEK	Kalrez®
E	PFA	EPDM
F	PFA	FKM
G	PFA	Kalrez®

CE-compliant

Nil	None
Q	CE-compliant

Lead wire length

Nil	300 mm
6	600 mm
10	1000 mm

Option

Nil	None
1	Bracket
2	Manual override
3	Bracket, Manual override

* Without a sub-plate, a bracket cannot be attached.

Sub-plate material/Port size

Nil	Without sub-plate	
1*	PVDF	M6
1U*	PVDF	1/4-28UNF
2	PFA	M6
2U	PFA	1/4-28UNF

* Combinations with wetted part materials E, F, G, are not available.

Kalrez® is a registered trademark of E. I. du Pont de Nemours and Company or its affiliates.

LVM10/100 Series

Specifications



Body ported



Body ported
(Tubing type)



Base mounted
(Without sub-plate)



Base mounted
(With sub-plate)

Model	Body ported	Body ported (Tubing type)			Base mounted			
	LVM11	LVM10R1	LVM10R2	LVM102R	LVM10R3	LVM10R4	LVM10R6	LVM105R
Valve construction	Diaphragm type direct operated poppet	Diaphragm type direct operated poppet (Rocker type)						
Valve type	N.C.	N.C.	N.O.	Universal	N.C.	N.O.	N.C.	Universal
Number of ports	2	2		3	2		3	
Fluid ^{Note 1)}	Air, Water, DI water (Pure water), Diluent, Cleaning fluid							
Operating pressure range	0 to 0.25 MPa	-75 kPa to 0.25 MPa						
Orifice diameter	1.5 mm	1.4 mm						
Response time ^{Note 6)}	10 ms or less (at pneumatic pressure)							
Leakage	Zero leakage, either external or internal (at water pressure)							
Proof pressure ^{Note 2)}	0.38 MPa							
Ambient temperature ^{Note 9)}	0 to 50°C							
Fluid temperature ^{Note 9)}	0 to 50°C (No condensation)							
Volume of valve chamber ^{Note 3)}	11 μL	20 μL						
Mounting orientation ^{Note 4)}	Free							
Enclosure	IP40 or equivalent							
Weight	30 g	34 g (without sub-plate), 42 g (with sub-plate)						
Rated voltage	12, 24 VDC							
Allowable voltage fluctuation ^{Note 5)}	±10% of rated voltage							
Type of coil insulation	Class B							
Power consumption (When rated voltage is at 24 V)	Standard	—		1.5 W (0.06 A)				
	With power-saving circuit	In-rush	2.5 W (0.1 A)					
	Hold-ing	1 W						
Coil switching noise ^{Note 6)}	50 dB							

Note 1) Select an appropriate material for the wetted part according to the fluid to be used. Additionally, check the chemical resistance beforehand.

Note 2) Indicates the pressure which does not generate breakage, cracks or external leakage after a one-minute airtight test.

Note 3) Indicates the volume of clearance inside the valve chamber after the volume of the diaphragm is subtracted.

Note 4) Since the body (orifice shape) is designed to eliminate residual liquid, mounting in a vertical direction with the coil at the top is recommended. When residual liquid is not considered, any mounting orientation is available.

Note 5) When the response speed is regarded as important, prevent negative fluctuation of the voltage by adequate regulation.

Note 6) The value is based on SMC's measurement conditions. The noise level will vary with conditions.

Note 7) Refer to 10 in "Design and Selection" on the back of page 553, if the valve is to be energized continuously for extended periods of time.

Note 8) In conformity with JIS B8419:2010 (valve at ambient and fluid temperature of 25°C, rated voltage, maximum operating pressure (air) and when the N.C. (IN) port is pressurized)

The response time may vary depending on the supply pressure, fluid, piping conditions and ambient temperature.

Note 9) When the diaphragm material is Kalrez®, take great care since the valve changeover time becomes significantly long at ambient and fluid temperature of 15°C or less when compared to that at room temperature (-25°C).

Flow Rate Characteristics

Valve construction	Water		Air	
	Kv	Cv	C	b
Direct operated poppet	0.034	0.04	0.13	0.22
Rocker type	0.025	0.03	0.1	0.2

* The values of Kv and Cv are based on JIS B 2005:1995, C and b are based on JIB B 8390:2000.

Kalrez® is a registered trademark of E. I. du Pont de Nemours and Company or its affiliates.

Construction: Body Ported

LVM11

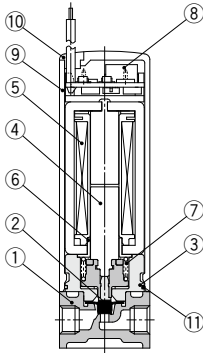

Component Parts: LVM11

No.	Description	Material
1	Body	PEEK
2	Diaphragm assembly	EPDM/FKM/Kalrez®
3	Spacer	PBT
4	Armature assembly	Stainless steel/POM
5	Coil assembly	—
6	Sleeve	SUY
7	Return spring	Stainless steel
8	Board assembly	—
9	Casing	PBT
10	Plug	NBR
11	O-ring	NBR

LVM10R1

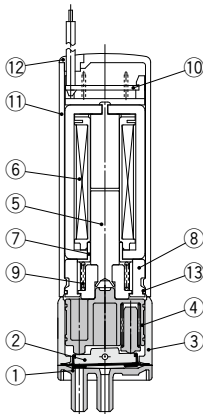

LVM10R2

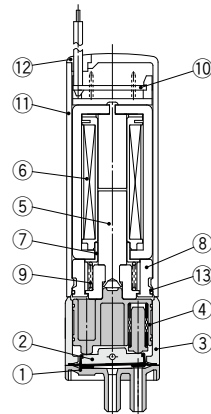

LVM102R

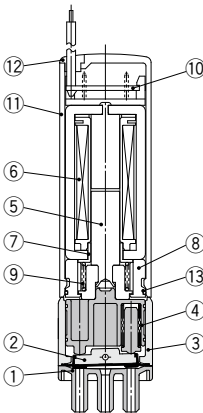

Component Parts: LVM10R1, 10R2, 102R

No.	Description	Material
1	Plate	PEEK
2	Diaphragm assembly	EPDM/FKM/Kalrez®
3	Body	PBT
4	Slide bushing assembly	PPS/Stainless steel
5	Armature assembly	Stainless steel/PBT
6	Coil assembly	—
7	Sleeve	SUY
8	Spacer	PBT
9	Return spring	Stainless steel
10	Board assembly	—
11	Casing	PBT
12	Plug	NBR
13	O-ring	NBR

- VCH
- VDW
- SX10
- VQ
- LVM**

LVM10/100 Series

Construction: Base Mounted

LVM10R3

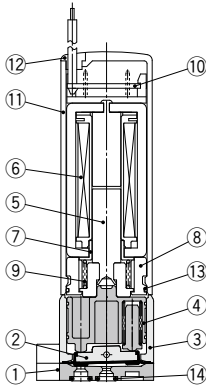

LVM10R4

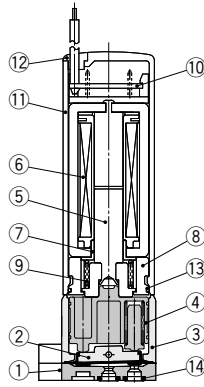

LVM10R6

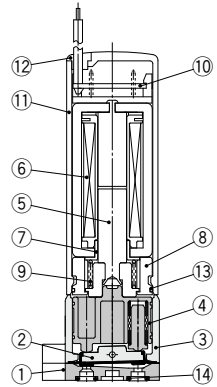

LVM105R

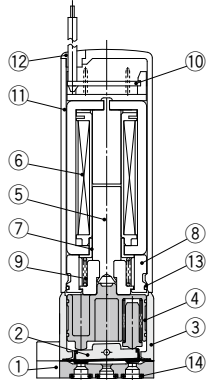

Component Parts: LVM10R3, 10R4, 10R6, 105R

No.	Description	Material
1	Plate	PEEK/PFA
2	Diaphragm assembly	EPDM/FKM/Kalrez®
3	Body	PBT
4	Slide bushing assembly	PPS/Stainless steel
5	Armature assembly	Stainless steel/PBT
6	Coil assembly	—
7	Sleeve	SUY
8	Spacer	PBT
9	Return spring	Stainless steel
10	Board assembly	—
11	Casing	PBT
12	Plug	NBR
13	O-ring	NBR
14	O-ring	EPDM/FKM/Kalrez®

Kalrez® is a registered trademark of E. I. du Pont de Nemours and Company or its affiliates.

Dimensions: Body Ported

LVM11-□□-□ (N.C.)

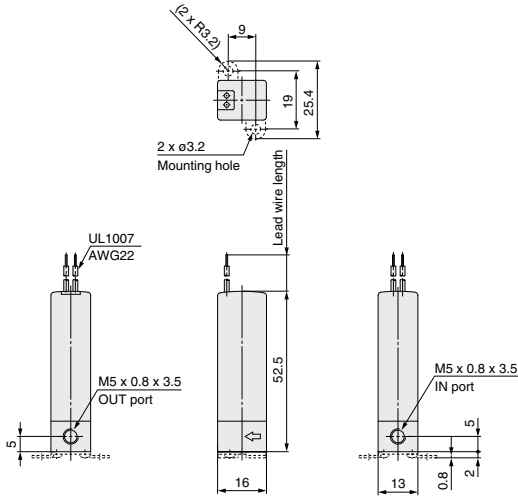

LVM10R1-□□-□ (N.C.)

LVM10R2-□□-□ (N.O.)

LVM102R-□□-□ (Universal)

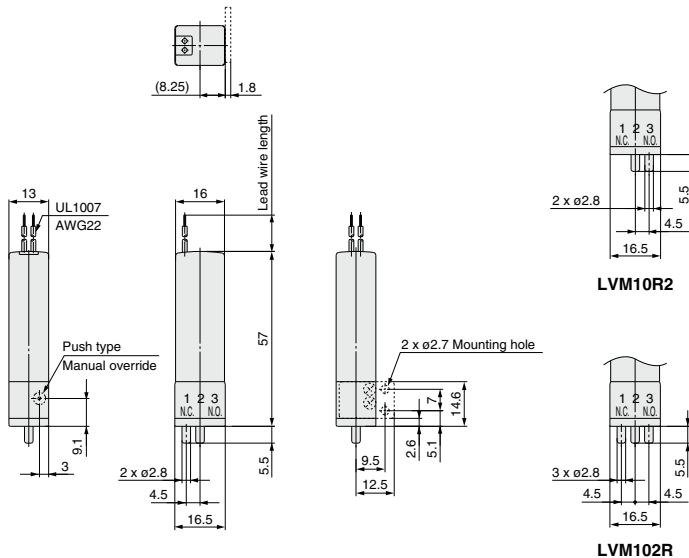

* The broken lines indicate with bracket.

VCH
VDW
SX10
VQ
LVM

Compact Direct Operated 2/3 Port Solenoid Valve for Chemical Liquids *LVM10/100 Series*

Dimensions: Base Mounted

LVM10R3-□□□□ (N.C.)

LVM10R4-□□□□ (N.O.)

LVM10R6-□□□□ (N.C.)

LVM105R-□□□□ (Universal)

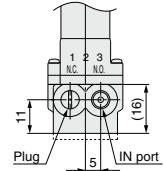
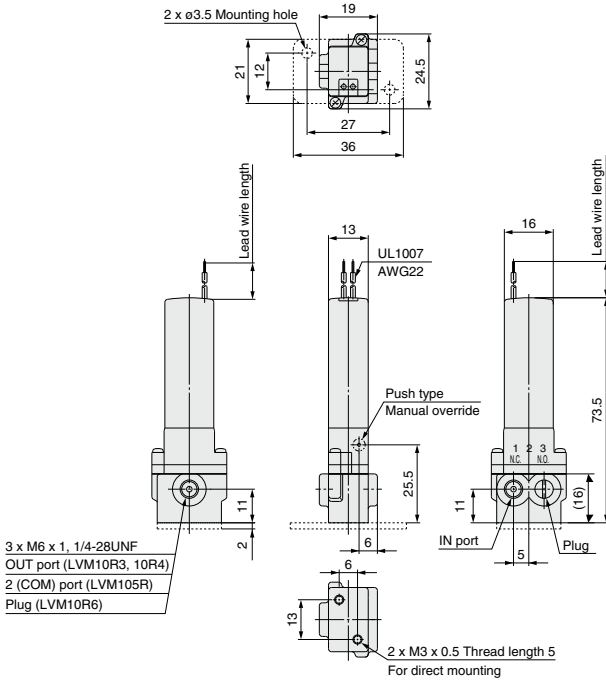

LVM10R4

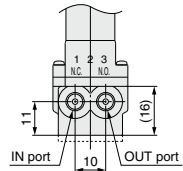

LVM10R6

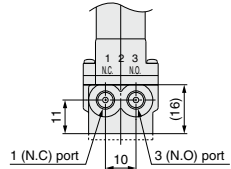

LVM105R

* The broken lines indicate with bracket.

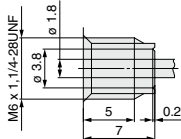

Details of thread

VCH □

VDW

SX10

VQ

LVM

Compact Direct Operated 2/3 Port Solenoid Valve for Chemical Liquids

LVM15/150 Series

How to Order



Base mounted (Without sub-plate) Base mounted (With sub-plate)

Base mounted

LVM 15R3 Y - 5 A 1 - - -

Series

Symbol	Number of ports	Valve type	
15R3	2	N.C.	
15R4		N.O.	
155R	3	Universal	

Sub-plate material/port size

	Without sub-plate		
1	M6	PVDF	
1U	1/4-28UNF	PVDF	

Lead wire length

NH	300 mm
6	600 mm
10	1000 mm

Coil voltage

Symbol	Voltage
5	24 VDC
6	12 VDC

Wetted part material

Symbol	Plate	Diaphragm
A	PEEK	EPDM
B	PEEK	FKM
C	PEEK	Kalrez®

Function

Symbol	Specifications
Y	Standard (With power-saving circuit)
HY	High-pressure type (With power-saving circuit)

CE-compliant

NH	None
Q	CE-compliant

Specifications

Model	Base mounted		
	LVM15R3	LVM15R4	LVM155R
Valve construction	Diaphragm type direct operated poppet (Rocker type)		
Valve type	N.C.	N.O.	Universal
Number of ports	2		3
Fluid Note 1)	Air, Water, DI water (Pure water), Diluent, Cleaning fluid		
Operating pressure range	-75 kPa to 0.25 MPa [Max. 0 to 0.6 MPa] Note 8)		
Orifice diameter	1.6 mm [1 mm]		
Response time Note 9)	15 ms or less (at pneumatic pressure)		
Leakage	Zero leakage, either external or internal (at water pressure)		
Proof pressure Note 2)	0.38 MPa [0.9 MPa]		
Ambient temperature Note 10)	0 to 50°C		
Fluid temperature Note 10)	0 to 50°C (No condensation)		
Volume of valve chamber Note 3)	50 μ L		
Mounting orientation Note 4)	Free		
Enclosure	IP40 or equivalent		
Weight	45 g (Without sub-plate), 56 g (With sub-plate)		
Rated voltage	12, 24 VDC		
Allowable voltage fluctuation Note 5)	\pm 10% of rated voltage		
Type of coil insulation	Class B		
Power consumption (When rated voltage is at 24 V)	Inrush	5.5 W(0.23 A)	
	Holding	1 W	
Coil switching noise Note 6)	60 dB		

Note 1) Select an appropriate material for the wetted part according to the fluid to be used. Additionally, check the chemical resistance beforehand.

Note 2) Indicates the pressure which does not generate breakage, cracks or external leakage after a one-minute airtight test.

Note 3) Indicates the volume of clearance inside the valve chamber after the volume of the diaphragm is subtracted.

Note 4) Since the body (orifice shape) is designed to eliminate residual liquid, mounting in a vertical direction with the coil at the top is recommended. When residual liquid is not considered, any mounting orientation is available.

Note 5) When the response speed is regarded as important, prevent negative fluctuation of the voltage by adequate regulation.

Note 6) The value is based on SMC's measurement conditions. The noise level will vary with conditions.

Note 7) Refer to 10 in "Design and Selection" on the back of page 553. If the valve is to be energized continuously for extended periods of time.

Note 8) The high-pressure type can also be used at a pressure level of up to -75 kPa. However, set the maximum operating pressure so that a difference in operating pressure becomes 0.6 MPa or less.

Example) When the valve is used at -50 kPa, the maximum operating pressure is up to 0.55 MPa.

Note 9) In conformity with JIS B8419:2010 (valve at ambient and fluid temperature of 25°C, rated voltage, maximum operating pressure (air) and when the N.C. (IN) port is pressurized)

The response time may vary depending on the supply pressure, fluid, piping conditions and ambient temperature.

Note 10) When the diaphragm material is Kalrez®, take great care since the valve changeover time becomes significantly long at ambient and fluid temperature of 15°C or less when compared to that at room temperature (\approx 25°C).

Flow Rate Characteristics

Water		Air	
Kv	Cv	C	b
0.034	0.04	0.13	0.22
[0.012]	[0.015]	[0.05]	[0.2]

[] indicates high-pressure type.

* The values of Kv and Cv are based on JIS B 2005:1995, C and b are based on JIS B 8390:2000.

Kalrez® is a registered trademark of E. I. du Pont de Nemours and Company or its affiliates.

[] indicates high-pressure type.

Construction: Base Mounted

LVM15R3

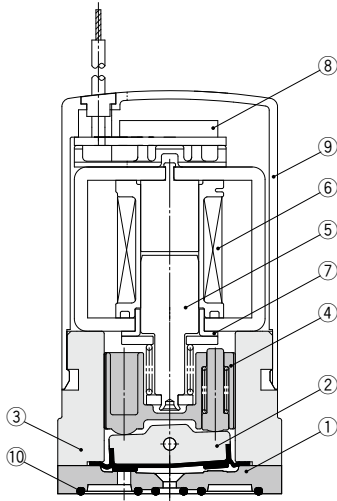

LVM15R4

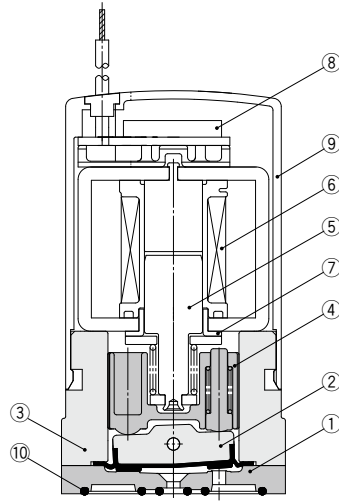

LVM155R

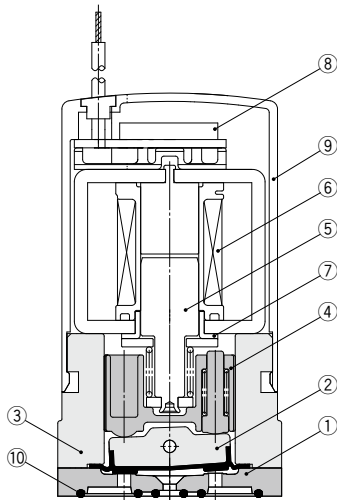

- VCH
- VDW
- SX10
- VQ
- LVM**

Component Parts: LVM15R3, 15R4, 155R

No.	Description	Material
1	Plate	PEEK
2	Diaphragm assembly	EPDM/FKM/Kalrez®
3	Body	PBT
4	Slide bushing assembly	PPS/Stainless steel
5	Armature assembly	—
6	Coil assembly	—
7	Sleeve	SUY
8	Board assembly	—
9	Casing	PBT
10	Interface gasket	EPDM/FKM/Kalrez®

Kalrez® is a registered trademark of E. I. du Pont de Nemours and Company or its affiliates.

LVM15/150 Series

Dimensions: Base Mounted

LVM15R3Y-□-□-□ (N.C.)

LVM15R4Y-□-□-□ (N.O.)

LVM155RY-□-□-□ (Universal)

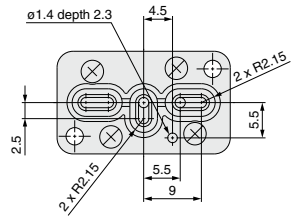
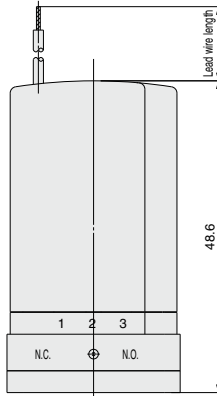
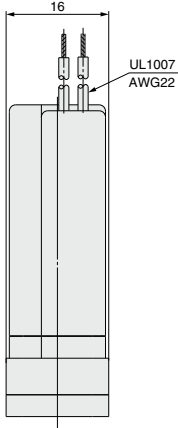
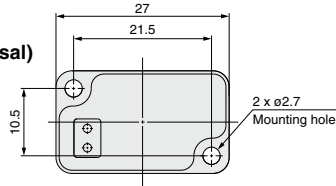

LVM15R4

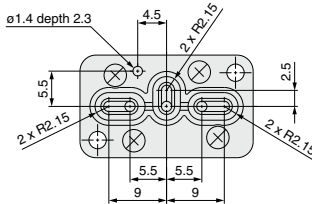

LVM155R

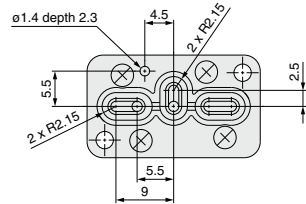

LVM15R3

Recommended interface dimensions

* Surface roughness = Rz3.2 or less

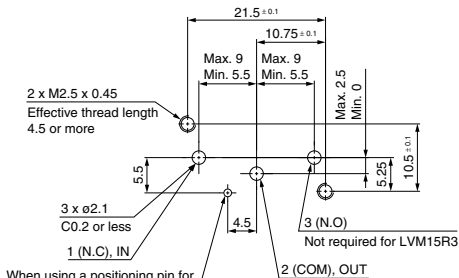

LVM155R, LVM15R3

* Surface roughness = Rz3.2 or less

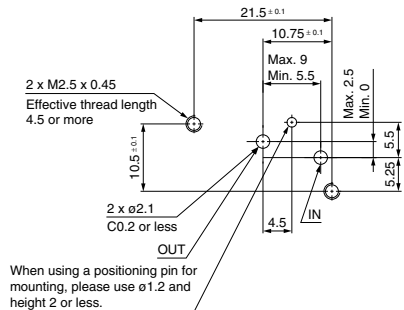

LVM15R4

When using a positioning pin for mounting, please use $\phi 1.2$ and height 2 or less.

When using a positioning pin for mounting, please use $\phi 1.2$ and height 2 or less.

**Compact Direct Operated
2/3 Port Solenoid Valve for Chemical Liquids** *LVM15/150 Series*

Dimensions: Base Mounted

LVM15R3Y-□□□-□ (N.C.)

LVM15R4Y-□□□-□ (N.O.)

LVM155RY-□□□-□ (Universal)

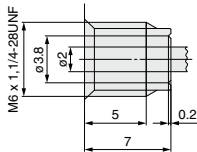
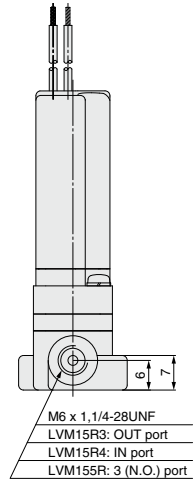
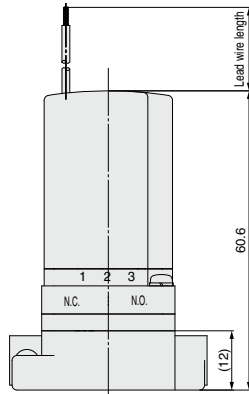
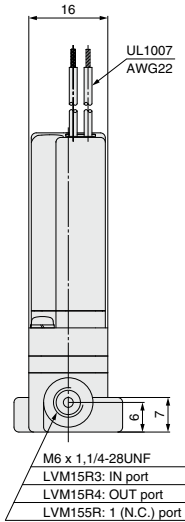
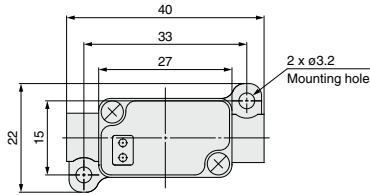

Details of thread

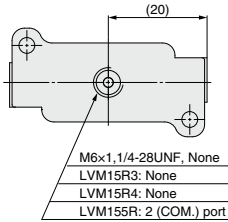

- VCH □
- VDW
- SX10
- VQ
- LVM**

Compact Direct Operated 2/3 Port Solenoid Valve for Chemical Liquids

LVM20/200 Series



How to Order



Body ported (Tubing type) Base mounted (Without sub-plate) Base mounted (With sub-plate)

Symbol	Number of ports	Valve type	
20R1	2	N.C.	
20R2	2	N.O.	
202R	3	Universal	

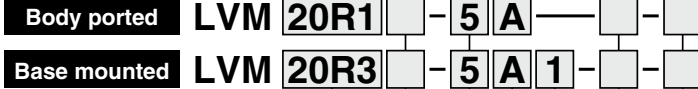

Symbol	Number of ports	Valve type	
20R3	2	N.C.	
20R4	2	N.O.	
205R	3	Universal	

Function

Nil	Standard
Y	With power-saving circuit

Coil voltage

Symbol	Voltage
5	24 VDC
6	12 VDC

Wetted part material

Symbol	Plate	Diaphragm
A	PEEK	EPDM
B	PEEK	FKM
C	PEEK	Kalrez®

CE-compliant

Nil	None
Q	CE-compliant

Lead wire length

Nil	300 mm
6	600 mm
10	1000 mm

Sub-plate material/Port size

Nil	Without sub-plate
1	Rc1/8 PVDF
1F	G1/8 PVDF
1N	NPT1/8 PVDF

Kalrez® is a registered trademark of E. I. du Pont de Nemours and Company or its affiliates.

Compact Direct Operated 2/3 Port Solenoid Valve for Chemical Liquids **LVM20/200 Series**

Specifications

Model	Body ported (Tubing type)			Base mounted		
	LVM20R1	LVM20R2	LVM20R	LVM20R3	LVM20R4	LVM20R5
Valve construction	Diaphragm type direct operated poppet (Rocker type)					
Valve type	N.C.	N.O.	Universal	N.C.	N.O.	Universal
Number of ports	2		3	2		3
Fluid ^{Note 1)}	Air, Water, DI water (Pure water), Diluent, Cleaning fluid					
Operating pressure range	-75 kPa to 0.25 MPa			-75 kPa to 0.3 MPa		
Orifice diameter	2 mm					
Response time ^{Note 8)}	20 ms or less (at pneumatic pressure)					
Leakage	Zero leakage, either external or internal (at water pressure)					
Proof pressure ^{Note 2)}	0.38 MPa			0.45 MPa		
Ambient temperature ^{Note 9)}	0 to 50°C					
Fluid temperature ^{Note 9)}	0 to 50°C (No condensation)					
Volume of valve chamber ^{Note 3)}	84μL					
Mounting orientation ^{Note 4)}	Free					
Enclosure	IP40 or equivalent					
Weight	80g			80g (Without sub-plate), 94g (With sub-plate)		
Rated voltage	12, 24 VDC					
Allowable voltage fluctuation ^{Note 5)}	±10% of rated voltage					
Type of coil insulation	Class B					
Power consumption (When rated voltage is at 24 V)	Standard		2.5 W (0.1A)			
	With power-saving circuit	Inrush	4 W (0.17A)			
		Holding	0.6 W			
			60dB			
Coil switching noise ^{Note 6)}						

Note 1) Select an appropriate material for the wetted part according to the fluid to be used. Additionally, check the chemical resistance beforehand.

Note 2) Indicates the pressure which does not generate breakage, cracks or external leakage after a one-minute airtight test.

Note 3) Indicates the volume of clearance inside the valve chamber after the volume of the diaphragm is subtracted.

Note 4) Since the body (orifice shape) is designed to eliminate residual liquid, mounting in a vertical direction with the coil at the top is recommended. When residual liquid is not considered, any mounting orientation is available.

Note 5) When the response speed is regarded as important, prevent negative fluctuation of the voltage by adequate regulation.

Note 6) The value is based on SMC's measurement conditions. The noise level will vary with conditions.

Note 7) Refer to 10 in "Design and Selection" on the back of page 553, if the valve is to be energized continuously for extended periods of time.

Note 8) In conformity with JIS B8419:2010 (value at ambient and fluid temperature of 25°C, rated voltage, maximum operating pressure (air) and when the N.C. (IN) port is pressurized)

The response time may vary depending on the supply pressure, fluid, piping conditions and ambient temperature.

Note 9) When the diaphragm material is Kalrez®, take great care since the valve changeover time becomes significantly long at ambient and fluid temperature of 15°C or less when compared to that at room temperature (~25°C).

Flow Rate Characteristics

Water		Air	
Kv	Cv	C	b
0.055	0.065	0.23	0.27

* The values of Kv and Cv are based on JIS B 2005:1995, C and b are based on JIB B 8390:2000.

Kalrez® is a registered trademark of E. I. du Pont de Nemours and Company or its affiliates.

VCH □

VDW

SX10

VQ

LVM

LVM20/200 Series

Construction: Body Ported

LVM20R1

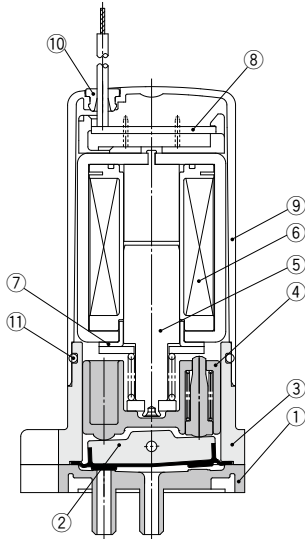

LVM20R2

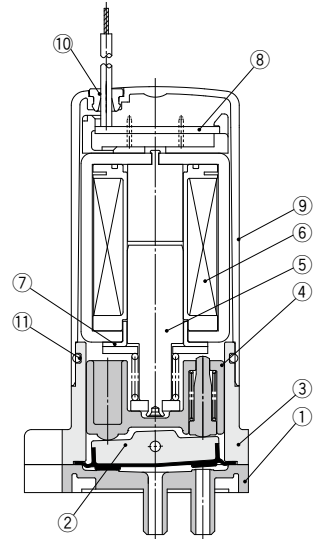

LVM202R

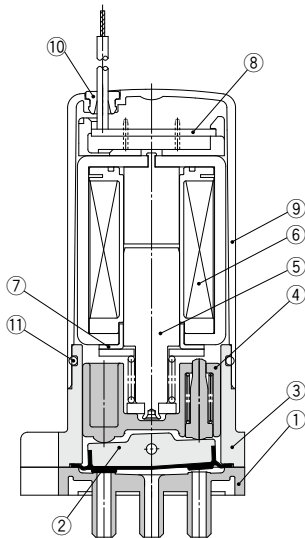

Component Parts: LVM20R1, 20R2, 202R

No.	Description	Material
1	Plate	PEEK
2	Diaphragm assembly	EPDM/FKM/Kalrez®
3	Body	PBT
4	Slide bushing assembly	PPS/Stainless steel
5	Armature assembly	—
6	Coil assembly	—
7	Sleeve	SUY
8	Board assembly	—
9	Casing	PBT
10	Plug	NBR
11	O-ring	NBR

Kalrez® is a registered trademark of E. I. du Pont de Nemours and Company or its affiliates.

Construction: Base Mounted

LVM20R3

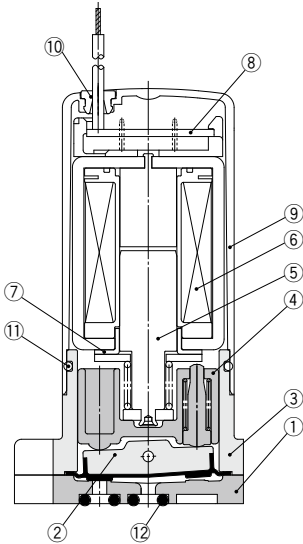

LVM20R4

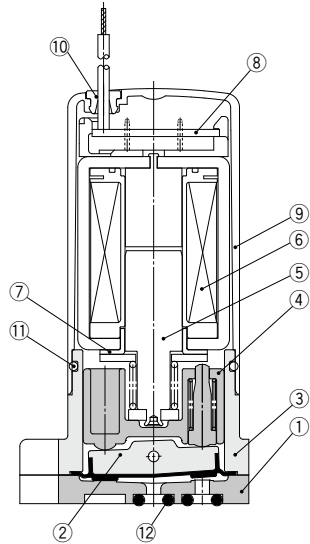

LVM205R

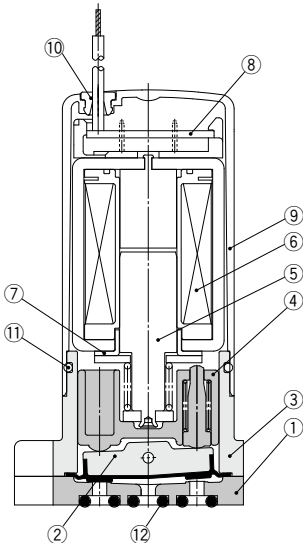

- VCH
- VDW
- SX10
- VQ
- LVM**

Component Parts: LVM20R3, 20R4, 205R

No.	Description	Material
1	Plate	PEEK
2	Diaphragm assembly	EPDM/FKM/Kalrez®
3	Body	PBT
4	Slide bushing assembly	PPS/Stainless steel
5	Armature assembly	—
6	Coil assembly	—
7	Sleeve	SUY
8	Board assembly	—
9	Plug	PBT
10	Plug	NBR
11	O-ring	NBR
12	O-ring	EPDM/FKM/Kalrez®

Kalrez® is a registered trademark of E. I. du Pont de Nemours and Company or its affiliates.

LVM20/200 Series

Dimensions: Body Ported

LVM20R1-□□-□ (N.C.)

LVM20R2-□□-□ (N.O.)

LVM202R-□□-□ (Universal)

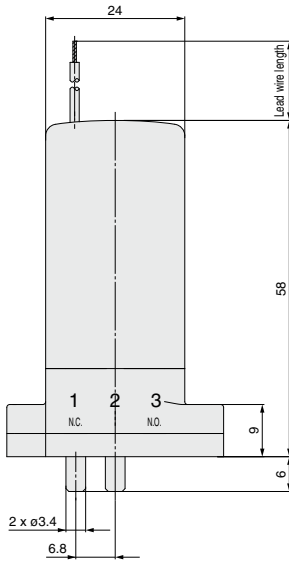
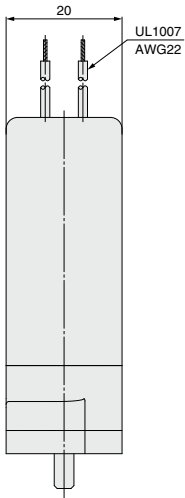
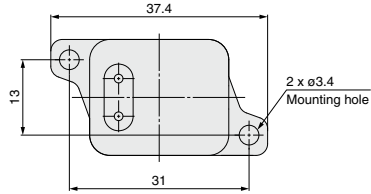

LVM20R1

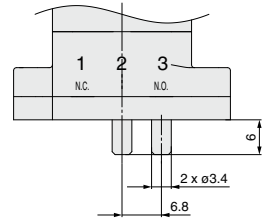

LVM20R2

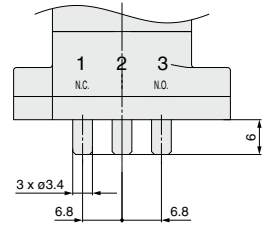

LVM202R

Compact Direct Operated
2/3 Port Solenoid Valve for Chemical Liquids ***LVM20/200 Series***

Dimensions: Base Mounted

LVM20R3-□□□ (N.C.)

LVM20R4-□□□ (N.O.)

LVM205R-□□□ (Universal)

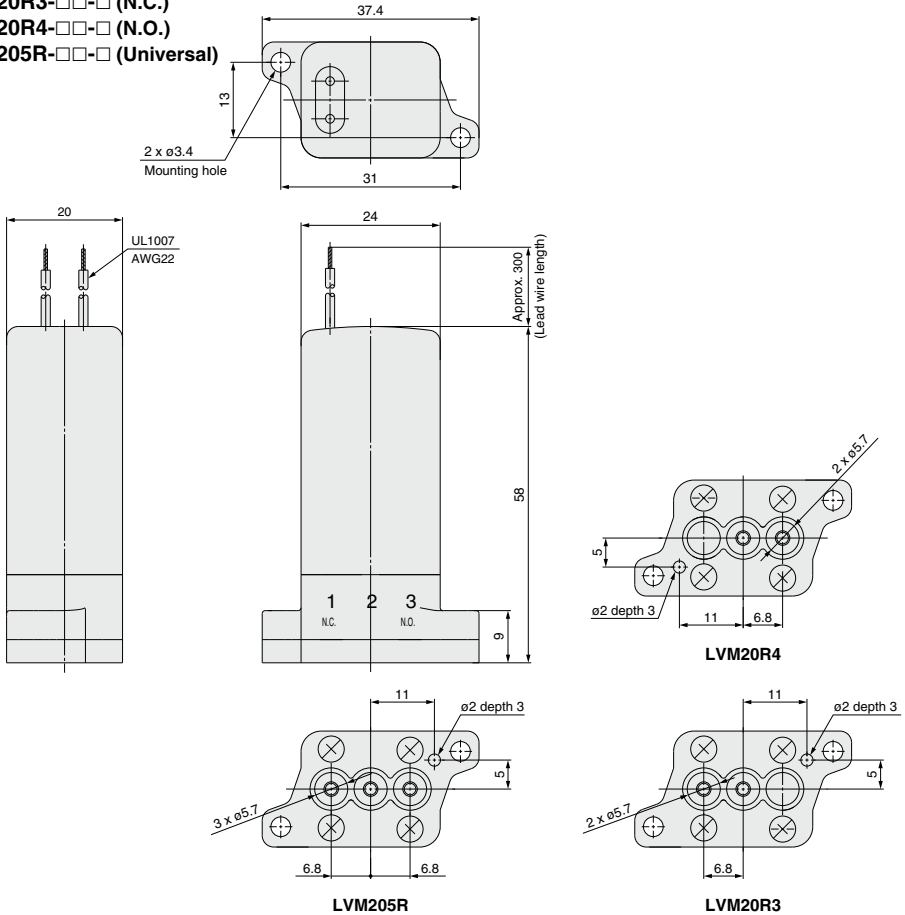

- VCH
- VDW
- SX10
- VQ
- LVM

Recommended interface dimensions

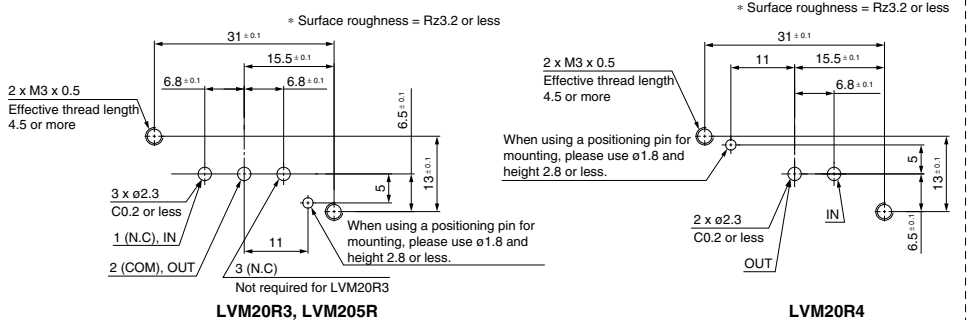

LVM20/200 Series

Dimensions: Base Mounted

LVM20R3-□□-□ (N.C.)

LVM20R4-□□-□ (N.O.)

LVM205R-□□-□ (Universal)

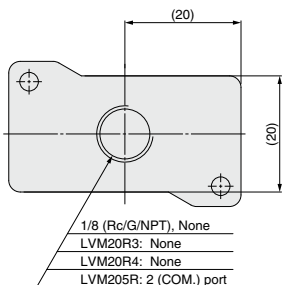
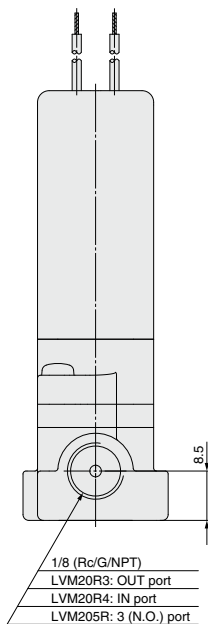
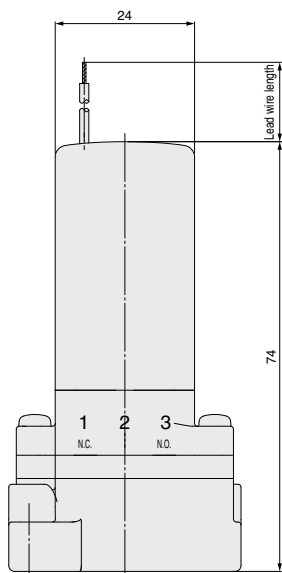
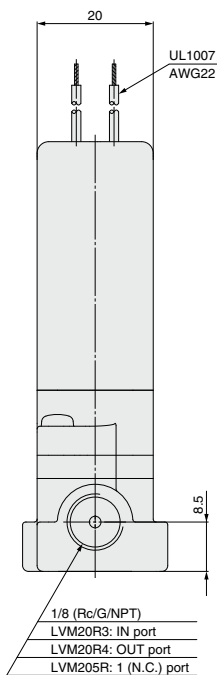
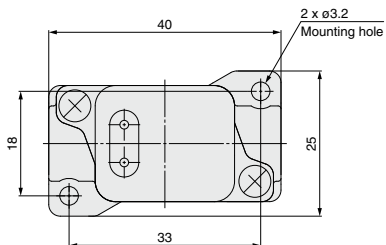



LVM Series Specific Product Precautions 1

Be sure to read this before handling the products. Contact SMC when it is used in conditions other than the specifications.

Design and Selection

Warning

1. Do not use this product in applications which may adversely affect human life (e.g. medical equipment connected to the human body for drip infusion).

2. Confirm the specifications.

Give careful consideration to the operating conditions such as the application, fluid and environment, and use within the operating ranges specified in this catalog.

3. Fluid

Be sure to confirm the compatibility between the component material and the fluid.

4. Maintenance space

The installation should allow sufficient space for maintenance activities.

5. Fluid pressure range

Fluid pressure should be within the allowable pressure range.

6. Ambient environment

Use within the allowable ambient temperature range. Be sure that the fluid used does not touch the external surface of the product.

7. Countermeasures against static electricity

Take measures to prevent static electricity since some fluids can cause static electricity.

8. Pressure (including vacuum) holding

It is not usable for an application such as holding the pressure (including vacuum) inside of a pressure vessel because air leakage is entailed in a valve.

9. Cannot be used as an emergency shutoff valve, etc.

The valves presented in this catalog are not designed for safety applications such as an emergency shutoff valve. If the valves are used in this type of system, other reliable safety assurance measures should also be adopted.

10. Extended periods of continuous energization

If solenoid valves are to be continuously energized for extended periods of time, use valves with power-saving circuits to minimize the amount of heat released by the coil.

Power-saving circuit waveform (example)

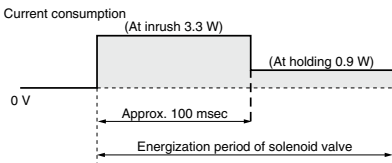

- * Power consumption for the waveform shown above is that of the LVM09/090.
- * For the LVM15/150, the type with power-saving circuit is standard.
- * For the LVM10/100, the inrush is 50 msec.

When a solenoid valve without a power-saving circuit is continuously energized for long periods of time, temperature increase from coil heat release can result in worsening performance and shortened service life of the solenoid valve, as well as adverse effects on peripheral equipment in the vicinity. For this reason, when valves are to be continuously energized for extended periods, use a fan or take other measures to disperse heat and keep valve surface temperatures at 70°C or less.

The table below shows reference values for continuously energized valves (single unit) when surface temperature is 70°C or less.

Series	LVM09/090	LVM10/100	LVM20/200
Period of continuous energization	5 min. or less	30 min. or less	30 min. or less
Duty ratio	50% or less		
Ambient temperature	25°C or less		
Power-saving circuit	None		

† Duty ratio: ON time/(ON time + OFF time)

* For the LVM15/150, the type with power-saving circuit is standard.

Please use a fan or take other measures to disperse heat and keep temperatures within the specified range when mounting the solenoid valves inside control panels, etc. Be especially careful when using three or more adjacent valves with manifolds and keeping them continuously energized for extended period, as this may result in dramatic increases in temperature.

11. Low temperature environments

Be aware that the valve changeover time becomes extremely long when the ambient and fluid temperature becomes 15°C or less as a reference when compared to the valve changeover time at room temperature (approx. 25°C). Diaphragm material: Kalrez®

Kalrez® is a registered trademark of E. I. du Pont de Nemours and Company or its affiliates.

Selection

Caution

Leakage voltage

The leakage voltage should be 2% or less of the rated voltage. If the leakage voltage exceeds this value, solenoid valve may not turn OFF.

Mounting

Caution

1. Always tighten threads with the proper tightening torque.

When mounting the solenoid valve, tighten it with the proper tightening torque shown below.

Tightening Torque for Base Mounting

Location	Model	Thread size	Proper tightening torque (N·m)
Base mounted	LVM09R3, 09R4, 095R	M2	0.1 to 0.14
	LVM10R3, 10R4, 10R6, 105R	M2	0.15 to 0.2
Body mounting	LVM15R3Y, 15R4Y, 155RY	M2.5	0.25 to 0.35
	LVM20R3, 20R4, 205R	M3	0.4 to 0.6

2. Mount the solenoid valve on the horizontal surface.

Applicable model: All models

3. Remove dust from the solenoid valve mounting surface completely. The surface roughness of the mounting surface should be Rz3.2 or less.

Applicable model: Base mounted

4. When mounting the solenoid valves next to each other, the valve pitch should be the value or more shown in the table below.

Series	LVM09/090	LVM10/100	LVM15/150	LVM20/200
Valve pitch	10.5	14	17	21

Applicable model: All models

Warning

5. If air leakage increases or equipment does not operate properly, stop operation.

After mounting, perform suitable function and leak tests to confirm that the mounting is correct.

6. Since the body (orifice shape) is designed to eliminate residual liquid, mounting in a vertical direction with the coil at the top is recommended.

When residual liquid is not considered, any mounting orientation is available.

VCH □

VDW

SX10

VQ

LVM



LVM Series Specific Product Precautions 2

Be sure to read this before handling the products. Contact SMC when it is used in conditions other than the specifications.

Piping

⚠ Caution

1. Preparation before piping

Before piping is connected, it should be thoroughly blown out with air (flushing) or washed to remove chips, cutting oil and other debris from inside the pipe.

2. When tubing is connected to the body ported solenoid valve, insert the tubing straight into the insertion part for a complete fit.

Select appropriate tubing while referring to the table below.

Model	Tube inside diameter (I.D.)	Tubing outside diameter (O.D.) (after mounting)
LVM10R1, 10R2, 10ZR	ø2.5 or less	ø4.5 or less
LVM20R1, 20R2, 20ZR	ø3.1 or less	ø6.8 or less

The holding force varies by the tubing material. Be sure to confirm the holding force of each material before operation.

After connecting the tubing, care should be taken not to put excessive force (tensile force, compression, bending, etc.) on the tubing. If an external force of 20 N or more is applied to the insertion part, this may cause leakage or damage to the insertion part.

3. When the tubing is long or according to the operating conditions, tubing may thrash about, causing damage to the tubing insertion part of the solenoid valve, or the tubing to come off or deteriorate.

In this case, secure the tubing to prevent its uncontrolled movement.

4. When piping the fitting to the solenoid valve, the installation method and tightening torque value may vary depending on the seal structure (shape) or material of the fitting to be used. Check the methods and precautions recommended by the fitting manufacturer to be used, and be sure to check for leakage.

The table below shows the tightening method using the KQ series.

Model	Location	Thread size	Tightening method	Tightening torque N·m (Reference)
LVM11	Body	M5	After tightening by hand, tighten 1/6 to 1/4 turn with a tightening tool.	Material PEEK: 0.5 to 0.7
LVM10R3, 10R4, 10R6, 10SR	Base mounted (With sub-plate)	M6 or 1/4-28UNF	After tightening by hand, tighten 1/6 to 1/4 turn with a tightening tool.	Material PVDF: 0.6 to 0.8 Material PFA: 0.2 to 0.25
LVM15R3Y, 15R4Y, 15SR		M6 or 1/4-28UNF	After tightening by hand, tighten 1/6 to 1/4 turn with a tightening tool.	Material PVDF: 0.6 to 0.8
LVM20R3, 20R4, 20SR		Pc1/8 or NPT1/8	Tighten approximately 4 turns.	Material PVDF: 0.5 to 0.6
		G1/8	After tightening by hand, tighten 1/3 to 1/2 turn with a tightening tool.	Material PVDF: 0.4 to 0.6

Wiring

⚠ Caution

- Use electrical circuits which do not generate chattering in their contacts.
- Use voltage which is within $\pm 10\%$ of the rated voltage.
However, when the response time is important, control the voltage to avoid variation on the minus side.
- Apply the correct voltage.
Applying incorrect voltage may cause a malfunction or a burned coil.
- Connect the wires so that an external force of greater than 10 N is not applied to the lead wire.
Otherwise the coil will burn.
- Units with power-saving circuits use polarized electrical connections.
Red (+), Black (-)

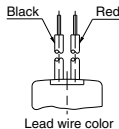

Fluid Properties

⚠ Warning

Liquid (chemicals)

Component crystallizes or clots depending on its nature. Leakage will occur when a crystallized or clotted component is caught between the sealing parts. Take measures to clean such component if necessary.

Water

Install a filter strainer of about 100 mesh on the inlet side of the piping.

Air

Compressed air filtered with a filter with filtration rating of 5 μm or less, which is mounted on the inlet side of the piping, should be used.

Operating Environment

⚠ Warning

- Do not use the product in a place where there is contact with corrosive gases, chemicals or liquids.
- Do not use in explosive atmospheres.
- Do not use in locations subject to excessive vibration or impact.
Impact resistance of this solenoid valve is 150 m/s^2 . Vibration resistance of this solenoid valve is 30 m/s^2 .
- Do not use in locations where radiated heat will be received from nearby heat sources.

Maintenance

⚠ Warning

1. Removing the product

Shut off the fluid supply and release the fluid pressure in the system. Shut off the power supply. Remove the product.

2. Before operating, remove residual chemicals and completely replace it with deionized water, air, etc.

3. Do not disassemble the product.

Products which have been disassembled cannot be guaranteed. If disassembly is necessary, contact SMC.

Return of Product

⚠ Warning

If the product to be returned is contaminated or is possibly contaminated with substances that are harmful to humans, for safety reasons, please contact SMC beforehand and then employ a specialist cleaning company to decontaminate the product. After the decontamination prescribed above has been carried out, submit a Product Return Request Sheet or the Detoxification/Decontamination Certificate to SMC and await SMC's approval and further instructions before attempting to return the item. Please refer to the International Chemical Safety Cards (ICSC) for a list of harmful substances. If you have any further questions, please don't hesitate to contact your SMC sales representative.