

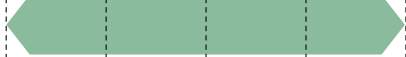













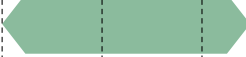









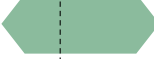

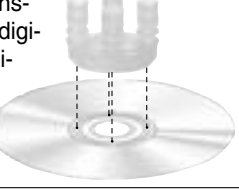
Pad Variations

| Type | Features | Guidelines for pad diameter range (mm)* | | | | | | |
|--|--|---|---|----------|----------|-------|-----------|------------|
| | | to 2 | 2 to 8 | 10 to 16 | 20 to 32 | 40/50 | 63 to 125 | 150 to 340 |
| Flat  | For adsorption of general work piece. For when the adsorption surface of a work piece is flat and not deformed. | |  | | | | | |
| Flat with ribs  | For when a work piece is likely to deform or in the case of releasing a work piece certainly. | |  | | | | | |
| Bellows  | General-purpose vacuum pad. For when the adsorption surface is inclined or there is no buffer space. | |  | | | | | |
| Deep  | For when a work piece is curved shape. | |  | | | | | |
| Thin flat / Thin flat with rib  | For a thin work piece such as paper and film, etc. | |  | | | | | |
| Heavy-load type  | For a large, heavy work piece. For adsorption of CRT tubes, automobile bodies, etc. | |  | | | | | |
| Heavy-load bellows type  | For heavy objects with a curved adsorption surface. Cardboard boxes, etc. | |  | | | | | |

* The above table provides guidelines. Pad diameter varies depending on the pad type. Refer to the each product specifications for details.

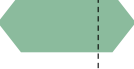
Pad Variations

| Type | Features | Guidelines for pad diameter range (mm)* | | | | | | |
|---|--|---|--|--|----------|-------|-----------|------------|
| | | to 2 | 2 to 8 | 10 to 16 | 20 to 32 | 40/50 | 63 to 125 | 150 to 340 |
| Ball joint type  | Pad suitable for adsorption of an inclined work piece. Ball joint angle 30° (Inclination 15°) | | |  | | | | |
| Multi-stage bellows  Made to Order | Suitable for adsorption of a work piece with a curved shape. A large angle of eccentricity can be achieved using the multi-stage bellows. Total height is lower than a metal spring type buffer.  | |  | | | | | |
| Disk adsorption  Made to Order | Vacuum pad for adsorption and transport of digital appliance disks (CDs, DVDs).  | | | | | | | |
| Panel fastening  Made to Order | For stage adsorption fastening of LCD panels, etc. Uses PTFE (fluororesin) at the work contact surface to prevent adsorption marks. | | |  | | | | |
| Clean  Made to Order | Rubber material pad for preventing the occurrence of adsorption marks on a work piece. | | |  | | | | |
| Spline buffer  Made to Order | Uses a ball spine guide for the buffer section. Achieves high-precision whirlistop. | |  | | | | | |
| Metal with buffer  Made to Order | Improves absorption position precision. A buffer mechanism absorbs shock on a work piece. Prevents ejection problems due to static electricity. | |  | | | | | |

* Contact SMC for details of the Made to Order mentioned above.











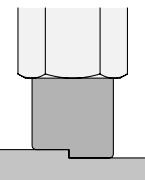

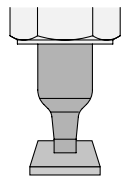
- ZA
- ZX
- ZR
- ZM
- ZMA
- ZQ
- ZH
- ZU
- ZL
- ZY□
- ZF□
- ZP□
- SP
- ZCUK
- AMJ
- AMV
- AEP
- HEP

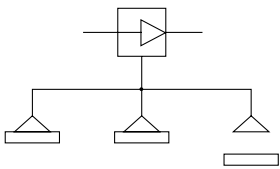
Related Equipment

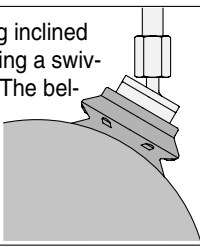
4

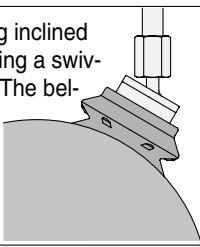

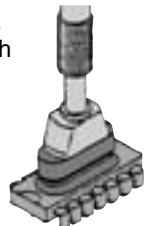







Vacuum Equipment

Pad Variations

| Type | Features | Guidelines for pad diameter range (mm)* | | | | | | |
|--|--|---|--------|----------|----------|-------|-----------|------------|
| | | to 2 | 2 to 8 | 10 to 16 | 20 to 32 | 40/50 | 63 to 125 | 150 to 340 |
| Sponge  Made to Order | For handling adsorption of a work piece with bumps, such as BGA ball surfaces, and electronic boards. The adapter end is equipped with rubber for absorbing shock at contact with the work piece.  | | ▶ | | | | | |
| Small diameter nozzle  Made to Order | For adsorption and transport of small parts such as IC chips.  | ▶ | | | | | | |
| Equipped with valve  Made to Order |  <p>A valve function is built into the vacuum pad. Vacuum is generated only when the pad has made contact with a work piece. Even if there is an adsorption problem with one ejector during multiple adsorption, there is no effect on the others.</p> | | | ▶ | | | | |
| Heavy-load with valve  Made to Order | For handling adsorption of a work piece with bumps, such as BGA ball surfaces, and electronic boards. The adapter end is equipped with rubber for absorbing shock at contact with the work piece.  | | | | | ▶ | | |
| Large ball joint type  Made to Order | For handling inclined surfaces using a swiveling head. The bellows section can handle curved surfaces.  | | | | | ▶ | | |
| Elliptic  Partially Made to Order | For handling a work piece with limitations on the adsorption surface, such as boards and LCD panels, etc.  | | | | | | | |
| Thin flat  Made to Order | Through the adoption of a thin lip, an ideal pad for adsorption of a thin work piece, etc.  | | | | | ▶ | | |

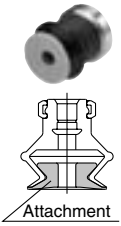
* Contact SMC for details of the Made to Order mentioned above.

Pad Variations



| Type | Features | Guidelines for pad diameter range (mm)* | | | | | | |
|---|---|---|--------|----------|----------|-------|-----------|------------|
| | | to 2 | 2 to 8 | 10 to 16 | 20 to 32 | 40/50 | 63 to 125 | 150 to 340 |
| Height reduction  Made to Order | Vacuum pad with reduced height dimension. Easy pad replacement using hexagonal socket for hexagonal wrench.  | | | | | | | |
| Blast  Made to Order | Improved work ejection due to blast-treated pad adsorption surface.  | | | | | | | |
| Large  Made to Order | Large pad suitable for $\phi 150$ to $\phi 340$.  | | | | | | | |
| Clean attachment  Made to Order | Does not leave adsorption marks (oils) on the work. (Material: PEEK) Applications: Adsorption processes for semiconductor and FPD related equipment, etc.  | | | | | | | |
| Anti-slip  Made to Order | Heavy-load pad for body welding press.  | | | | | | | |
| Adapter variations for heavy duty pad  Made to Order | | | | | | | | |

* Contact SMC for details of the Made to Order mentioned above.





- ZA
- ZX
- ZR
- ZM
- ZMA
- ZQ
- ZH
- ZU
- ZL
- ZY□
- ZF□
- ZP□
- SP
- ZCUK
- AMJ
- AMV
- AEP
- HEP

Related Equipment

Air Suction Filter Variations

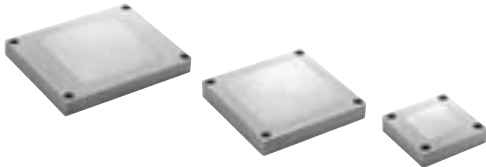
| | | ZFA | | ZFB | | | | ZFC | | | | |
|--------------------------------|------------------------|---|-----|--|----|----|----|---|-----|----|----|----|
| Series | |  P.1105 | |  P.1108 | | | |  P.1111 | | | | |
| Features | | Pleated element provides a large filter area. Manifold capable. | | Piping tube mounting direction can be freely set through 360°. With One-touch fitting. | | | | IN, OUT straight pipe. With One-touch fitting. | | | | |
| Port size | Screw-in | 1/8 | 1/4 | — | — | — | — | — | — | — | — | — |
| | One-touch fitting O.D. | — | — | 4 | 6 | 8 | 10 | 2 | 3.2 | 4 | 6 | 8 |
| Flow rate [l/min(ANR)] | | 50 | 200 | 10 | 30 | 50 | 75 | 2 | 7 | 10 | 30 | 50 |
| Nominal filtration rating (μm) | | 30 | | 30 | | | | 10 | | | | |





Related Equipment

| | | SP | | ZCUK | |
|----------|--|--|--|--|--|
| Series | | Adsorption plate  P.1239 | | Free Mount Cylinder for Vacuum  P.1249 | |
| Features | | <ul style="list-style-type: none"> • Ideal for adsorption and fixing in place of thin sheets, glass panels, and soft workpieces. Workpieces do not deform since they are adsorbed with multiple micro air vents on the adsorption surface. • A high level of machining accuracy. • Strong adsorption force. | | <ul style="list-style-type: none"> • In the rectangular, compact cylinder series CU which have a high level of mounting precision, a vacuum passage is provided in the rod to facilitate the mounting of a vacuum pad, and save space. • Standard vacuum pads (ø2 to ø50) can be mounted. | |
| Series | | Drain Separator for the Vacuum  P.1263 | | Exhaust Cleaner for Vacuum  P.1268 | |
| Features | | <ul style="list-style-type: none"> • Removes water droplets from air by simply installing in vacuum equipment connection lines. • Effective for removing water droplets from the air sucked into vacuum pumps and ejectors, etc. | | <ul style="list-style-type: none"> • Captures 99.5% of oil mist exhausted from the vacuum pump. • Creates a comfortable working environment without oil mist. • Captures and separates 99.5% of highly concentrated oil mist with a low flow rate. • No need for an exhaust duct from the vacuum pump. | |

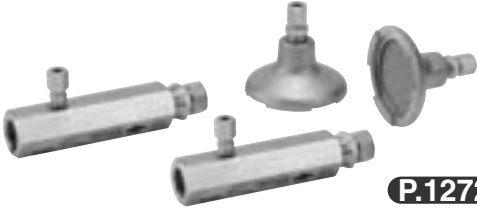
Air Suction Filter Variations/Related Equipment

Related Equipment

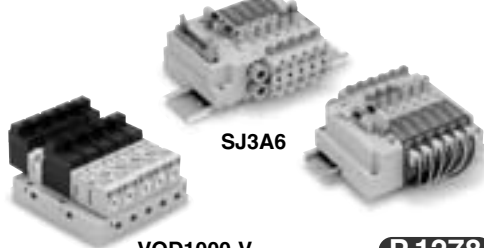
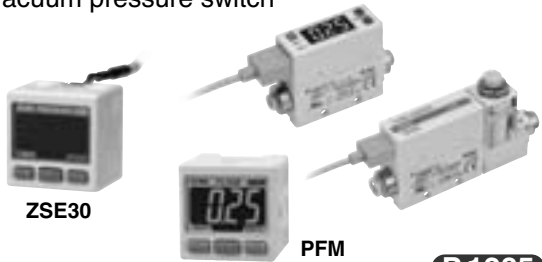
| | AEP | HEP500 |
|----------|---|---|
| Series | Liquid Collector/Exhaust Pressure Type  P.1270 | Liquid Collector/Ejector Type  P.1272 |
| Features | <ul style="list-style-type: none"> • Collect and reuse the leaked lubricating or hydraulic fluid using exhaust pressure. • Collect it using the exhausted air released from the switching valve into the atmosphere, realizing energy saving. • Efficient operation eliminating collection and wiping by hand. | <ul style="list-style-type: none"> • Collects the leakage of expensive cutting and grinding oil. • No need to collect the leaked liquid by hand. • Possible to use the equipped pump, special driving force is not required. |

| | Related Equipment for Vacuum System | | | |
|--------|--|--|---|--|
| Series | Vacuum Regulator  P.1276 | Electronic Vacuum Regulator  P.1277 | Directional control valve  P.1278 | |
| | Vacuum pressure switch  P.1285 | Vacuum Pressure Gauge  P.1289 | | |
| | Flow control equipment  P.1290 | Made to Order ① Vacuum release valve with throttle valve: SY5A2R ② Vacuum release valve with throttle valve: SV1A4R-X8 ③ Air suction filter: FGZG220A P.1291 | | |

Adsorption Transfer System by Ejector

Ejector Module System

Equipment (ejector supply valve, release valve, throttle valve, vacuum pressure switch, and filter) that is needed for the ejector adsorption transfer system has been integrated to achieve efficient assembly work and a compact design.

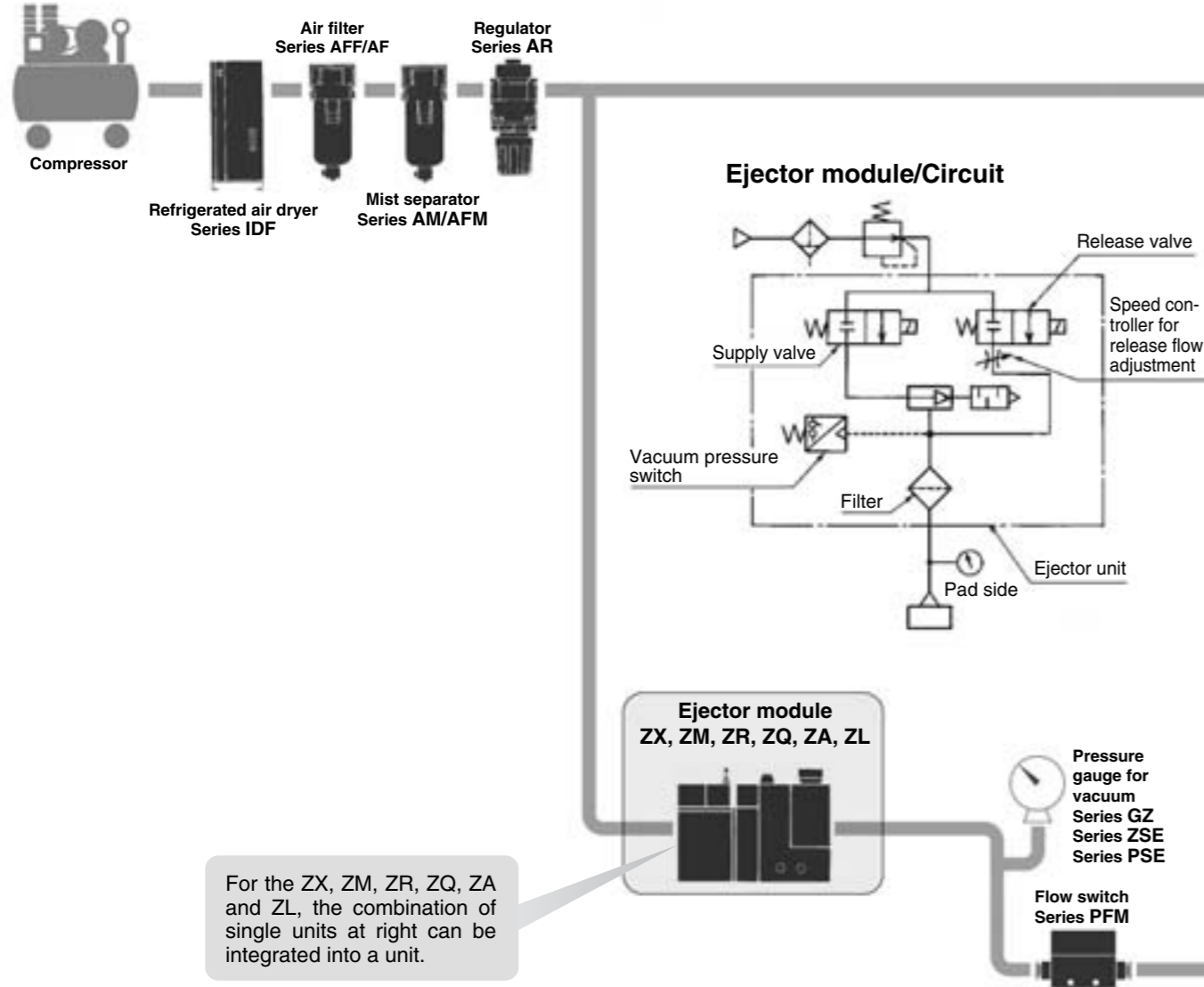

Single Unit System

Equipment such as an ejector is configured as an individual unit. Thus, it is possible to create a flexible system configuration in which the circuit composition and the mounting locations can be selected as desired.

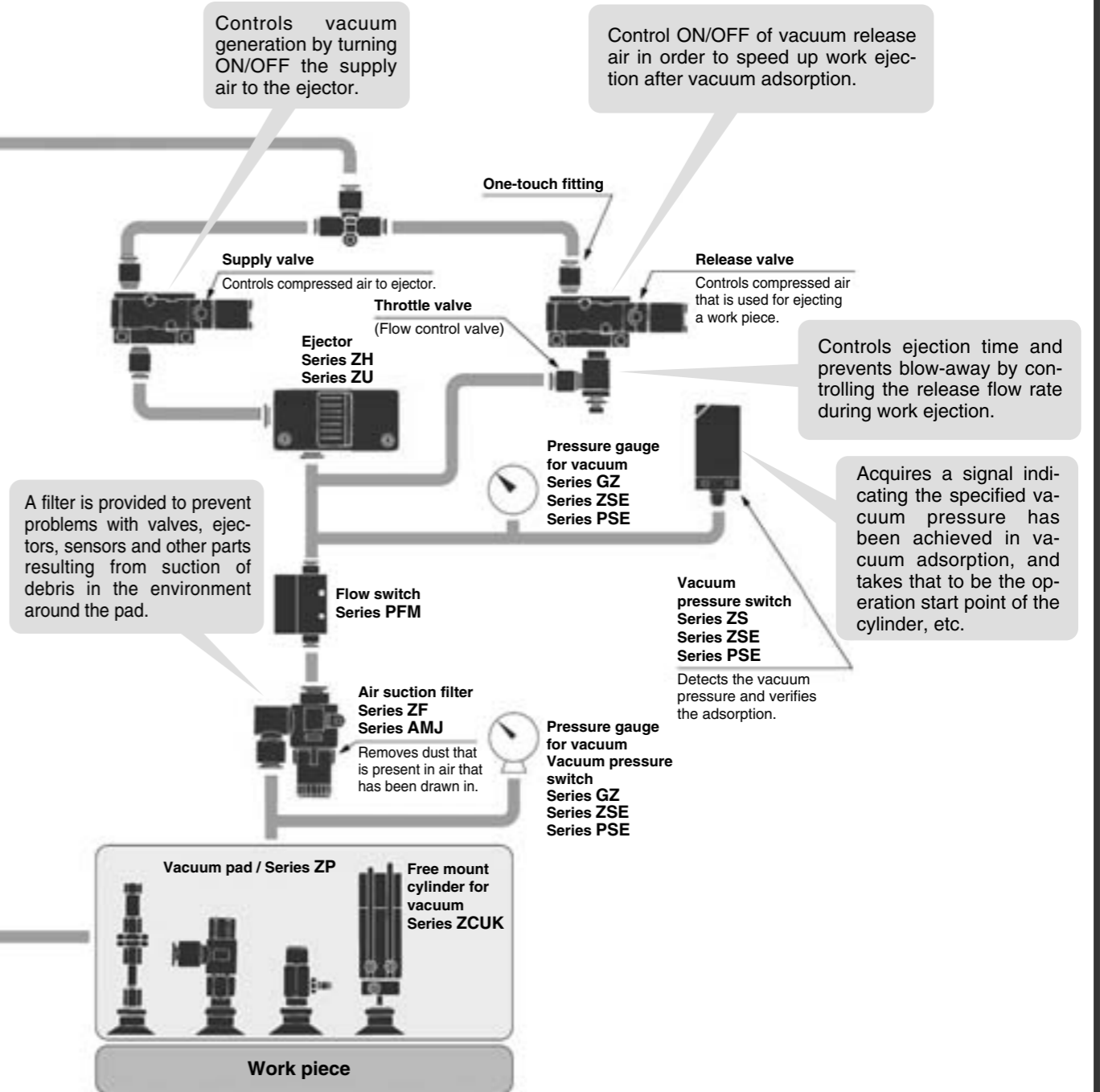

- ZA
- ZX
- ZR
- ZM
- ZMA
- ZQ
- ZH
- ZU
- ZL
- ZY□
- ZF□
- ZP□
- SP
- ZCUK
- AMJ
- AMV
- AEP
- HEP
- Related Equipment

Vacuum Equipment

Adsorption Transfer System for Vacuum Pump

Equipment (vacuum switching valve, release valve, throttle valve, vacuum pressure switch, and filter) that is needed for controlling the vacuum pressure has been integrated to achieve efficient assembly work and a compact design.

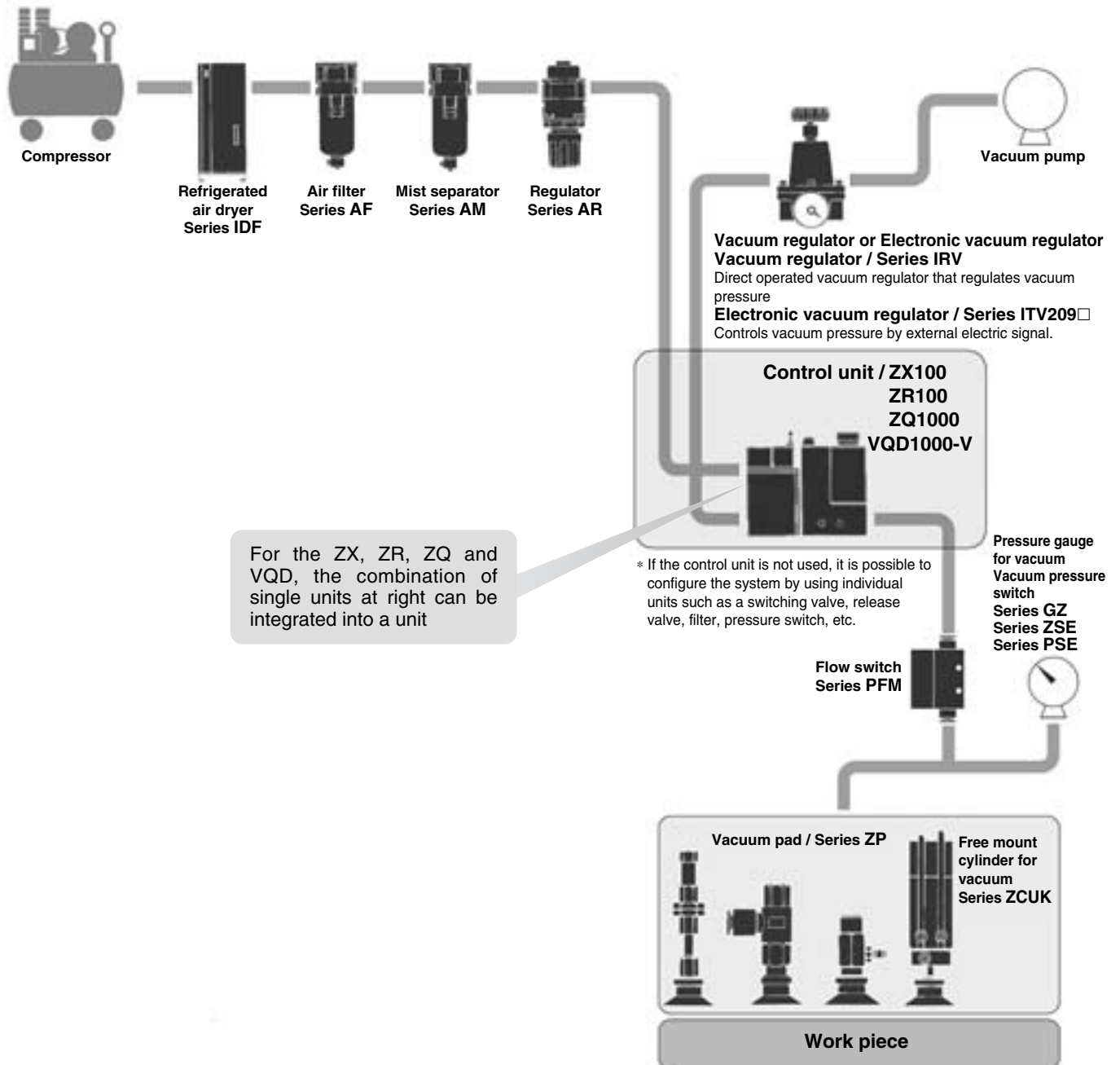

Control unit/Circuit

Regulator to control vacuum release pressure.

Control ON/OFF of vacuum release air in order to speed up work ejection after vacuum adsorption.

Controls ejection time and prevents blow-away by controlling the release flow rate during work ejection.

A filter is provided to prevent problems with valves, ejectors, sensors and other parts resulting from suction of debris in the environment around the pad.

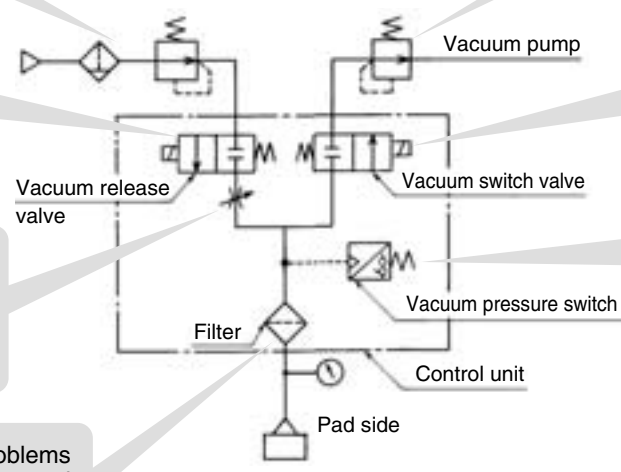

A vacuum regulator is provided to prevent pulsation of the vacuum source and maintain vacuum pressure at the specified pressure.

Control ON/OFF of the vacuum supplied from the vacuum pump.

Acquires a signal indicating the specified vacuum pressure has been achieved in vacuum adsorption, and takes that to be the operation start point of the cylinder, etc.

| |
|-------------------|
| ZA |
| ZX |
| ZR |
| ZM |
| ZMA |
| ZQ |
| ZH |
| ZU |
| ZL |
| ZY□ |
| ZF□ |
| ZP□ |
| SP |
| ZCUK |
| AMJ |
| AMV |
| AEP |
| HEP |
| Related Equipment |

Vacuum Equipment Model Selection

Contents

| | |
|---|--------------|
| 1. Features of Vacuum Adsorption | P.826 |
| 2. Vacuum Pad Selection | P.826 |
| ● Vacuum Pad Selection Procedures | |
| ● Points to be Considered when Selecting Vacuum Pads | |
| A. Theoretical Lifting Force | |
| B. Shear Force and Moment Applied to Vacuum Pad | |
| ● Lifting Force and Vacuum Pad Diameter | |
| 1. Theoretical Lifting Force | |
| 2. Finding the Pad Diameter | |
| ● Vacuum Pad Form | |
| ● Vacuum Pad Material | |
| ● Buffer Attachment | |
| ● Pad Selection for Work Types | |
| ● Vacuum Pad Durability | |
| 3. Selection of Vacuum Ejector and Vacuum Switching Valve | P.832 |
| ● Calculating Vacuum Ejector and Switching Valve Size with the Formula | |
| 4. Leakage at Work Adsorption | P.832 |
| ● Leakage from Effective Area of Work | |
| ● Leakage from Adsorption Test | |
| 5. Adsorption Response Time | P.833 |
| ● Relation between Vacuum Pressure and Response Time after Supply Valve (Switching Valve) is Operated | |
| ● Calculating Adsorption Response Time with the Formula | |
| ● Adsorption Response Time from the Selection Graph | |
| 6. Precautions on Vacuum Equipment Selection and SMC's Proposal | P.835 |
| ● Safety Measures | |
| ● Precautions on Vacuum Equipment Selection | |
| ● Vacuum Ejector or Pump and Number of Vacuum Pads | |
| ● Vacuum Ejector Selection and Handling Precautions | |
| ● Supply Pressure of Vacuum Ejector | |
| ● Timing for Vacuum Generation and Adsorption Confirmation | |
| A. Timing for Generating Vacuum | |
| B. Adsorption Confirmation | |
| C. Set Pressure for the Vacuum Pressure Switch | |
| ● Dust Handling of Vacuum Equipment | |
| 7. Vacuum Equipment Selection Example | P.839 |
| ● Transfer of Semiconductor Chips | |
| 8. Data | P.840 |
| ● Selection Graph | |
| ● Glossary of Terms | |
| ● Countermeasures for the Vacuum Adsorption System Problems (Troubleshooting) | |

ZA

ZX

ZR

ZM

ZMA

ZQ

ZH

ZU

ZL

ZY□

ZF□

ZP□

SP

ZCUK

AMJ

AMV

AEP

HEP

Related
Equipment

Model Selection

1. Features of Vacuum Adsorption

Vacuum adsorption system as a method to hold a workpiece has the following features.

- Easy construction
- Compatible with any place where adsorption is possible.
- No need for accurate positioning
- Compatible with soft and easily-deformed workpieces

However, special care is required in the following conditions.

- Workpiece may drop under certain conditions since it is transferred being adsorbed.
- Liquid or foreign matter around the workpiece may be sucked into the equipment.
- Large adsorption area is necessary to get large gripping force.
- Vacuum pad (rubber) may deteriorate.

Fully understand the features above and select the equipment that suits your operating conditions.

2. Vacuum Pad Selection

● Vacuum Pad Selection Procedures

- 1) Fully taking into account the balance of a workpiece, identify the adsorption positioning, number of pads and applicable pad diameter (or pad area).
- 2) Find the theoretical lifting force from the identified adsorption area (pad area x number of pads) and vacuum pressure, and then find the lifting force considering actual lifting and safety factor of transfer condition.
- 3) Determine a pad diameter (or pad area) that is sufficient to ensure the lifting force is greater than the workpiece mass.
- 4) Determine the pad form and materials, and the necessity of buffer based on the operating environment, and the workpiece shape and materials.

The above shows selection procedures for general vacuum pads; thus, they will not be applicable for all pads. Customers are required to conduct a test on their own and to select applicable adsorption conditions and pads based on the test results.

● Points to be Considered when Selecting Vacuum Pads

A. Theoretical Lifting Force

- The theoretical lifting force is determined by vacuum pressure and contact area of the vacuum pad.
- Since the theoretical lifting force is the value measured at the static state, the safety factor responding to the actual operating conditions must be estimated in the actual operation.
- It is not necessarily true that higher vacuum pressure is better. Extremely high vacuum pressure may cause problems.
 - When the vacuum pressure is unnecessarily high, pads are likely to be worn out quickly and cracked, which makes the pad service life shorter.
Doubling the vacuum pressure makes the theoretical lifting force double, while doubling the pad diameter makes the theoretical lifting force quadruple.
 - When the vacuum pressure (set pressure) is high, it makes not only response time longer, but also the necessary energy to generate a vacuum larger.

B. Shear Force and Moment Applied to Vacuum Pad

- Vacuum pads are not resistant to shear force (parallel force with adsorption surface) and moment.
- Minimize the moment applied to the vacuum pad with the position of the workpiece center of gravity in mind.
- The acceleration rate of the movement must be as small as possible, and make sure to take into consideration the wind pressure and impact. If measures to slow down the acceleration rate are introduced, safety to prevent the workpiece from dropping will improve.
- Avoid lifting the workpiece by adsorbing the vertical side with a vacuum pad (vertical lifting) if possible. When it is unavoidable, a sufficient safety factor must be secured.

Lifting Force, Moment, Horizontal Force

To lift a workpiece vertically, make sure to take into consideration the acceleration rate, wind pressure, impact, etc., in addition to the mass of the workpiece. (Refer to Fig. 1)

Because the pads are susceptible to moments, mount the pad so as not to allow the workpiece to create a moment. (Refer to Fig. 2)

When a workpiece that is suspended horizontally is moved laterally, the workpiece could shift depending on the extent of the acceleration rate or the size of the friction coefficient between the pad and the workpiece. Therefore, the acceleration rate of the lateral movement must be minimized. (Refer to Fig. 3)

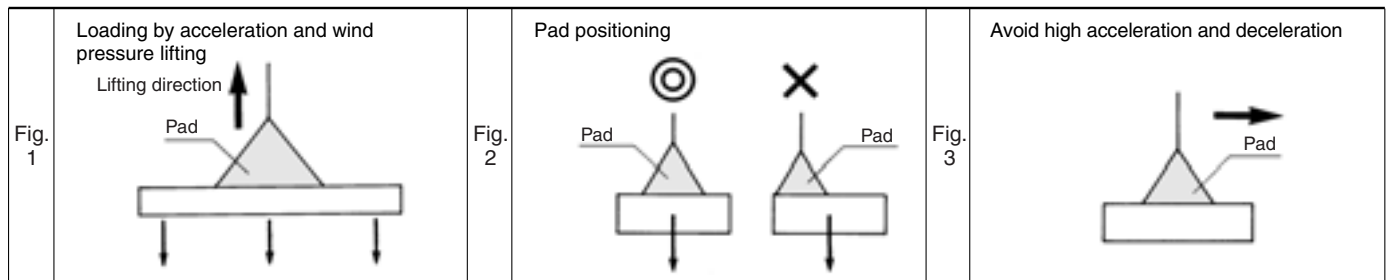

Balance of Pad and Work

Make sure that the pad's suction surface is not larger than the surface of the workpiece to prevent vacuum leakage and unstable picking.

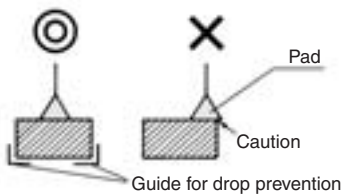

If multiple pads are used for transporting a flat object with a large surface area, properly allocate the pads to maintain balance. Also make sure that the pads are aligned properly to prevent them from becoming disengaged along the edges.

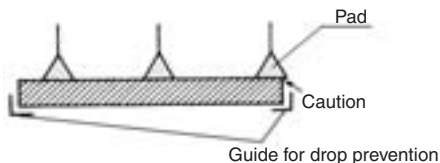

Provide an auxiliary device (example: a guide for preventing the workpieces from dropping) as necessary.

Mounting Position

As a rule, the unit must be installed horizontally. Although a diagonal or a vertical installation should be avoided whenever possible, if the unit must be installed in such a manner, be certain to guarantee guide and absolute safety.

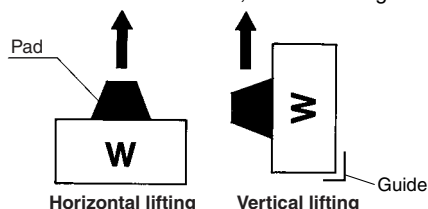

| |
|-------------------|
| ZA |
| ZX |
| ZR |
| ZM |
| ZMA |
| ZQ |
| ZH |
| ZU |
| ZL |
| ZY□ |
| ZF□ |
| ZP□ |
| SP |
| ZCUK |
| AMJ |
| AMV |
| AEP |
| HEP |
| Related Equipment |

2. Finding the Pad Diameter

A pad diameter which accounts for a safety factor based upon the workpiece lifting method (horizontal or vertical), can be selected by using the calculation formula or the selection graphs (graphs 1, 2 below).

Calculation

$$D = \sqrt{\frac{4}{3.14} \times \frac{1}{P} \times \frac{W}{n}} \times t \times 1000$$

D: Pad diameter (mm)
n: Number of pads per workpiece
W: Lifting force (N)

P: Vacuum pressure (kPa)
S: Pad area (cm²)
t: Safety factor
 horizontal lifting: 4 or more
 vertical lifting: 8 or more

Selection Graph

After establishing the workpiece mass, number of pads to be used, and the vacuum pressure when adsorbing the workpiece, the pad diameters for horizontal lifting and vertical lifting can be found by means of using graphs (1) and (2).

Selection Graph (1)-1 Pad Diameter Selection Graph by Lifting Force Horizontal Lifting (ø2 to ø50)

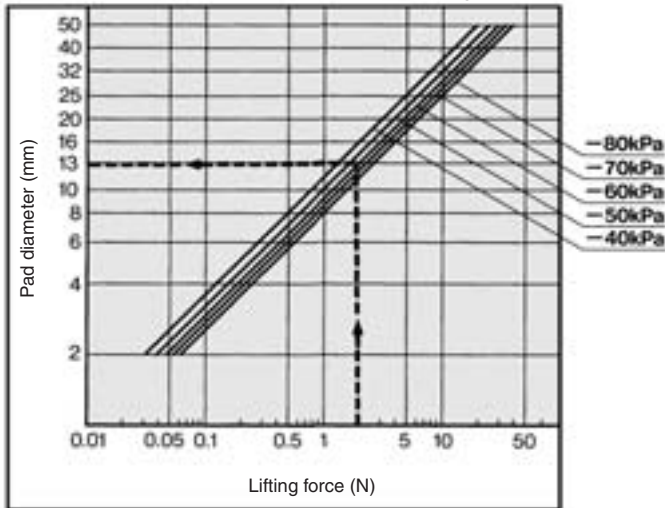

Selection Graph (2)-1 Pad Diameter Selection Graph by Lifting Force Vertical Lifting (ø2 to ø50)

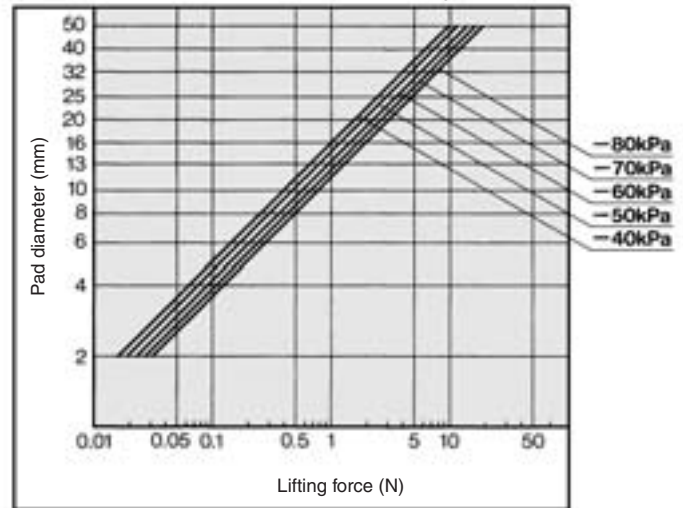

Selection Graph (1)-2 Pad Diameter Selection Graph by Lifting Force Horizontal Lifting (ø50 to ø250)

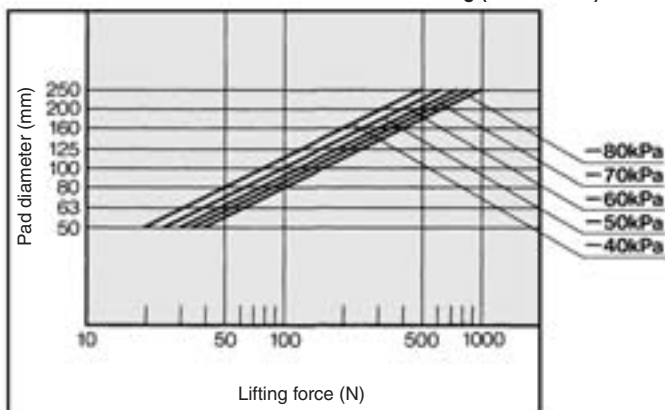

Selection Graph (2)-2 Pad Diameter Selection Graph by Lifting Force Vertical Lifting (ø50 to ø250)

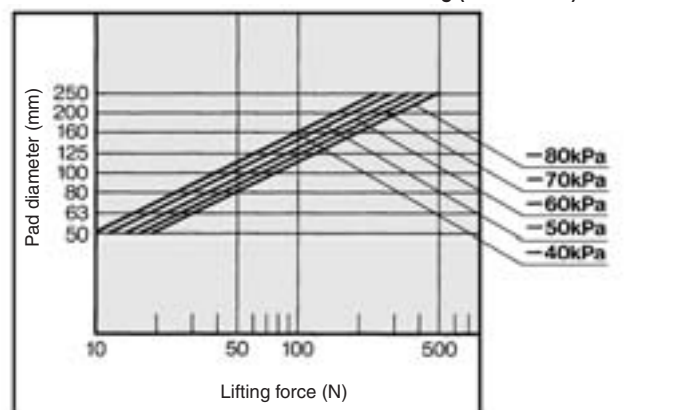

How to read the graph

Example: Workpiece mass 1 kg (Lifting force: 9.8 N)
 : Conditions/Number of pads: 5 pcs.
 Vacuum pressure -60 kPa
 Horizontal lifting

<Selection procedure>

From the conditions at the left, the lifting force per pad: 9.8 N ÷ 5 pcs. = 2 N, and for horizontal lifting, selection is made from graph (1)-1. Then, extending the intersection point of the lifting force 2 N and with a vacuum pressure of -60 kPa to the left, a pad diameter of ø13 is obtained. Therefore, a pad diameter of ø13 or greater should be selected.

- ZA
- ZX
- ZR
- ZM
- ZMA
- ZQ
- ZH
- ZU
- ZL
- ZY□
- ZF□
- ZP□
- SP
- ZCUK
- AMJ
- AMV
- AEP
- HEP





Related Equipment





Model Selection

● Vacuum Pad Form

- Vacuum pads are available in flat, deep, bellows, thin flat, with ribs and elliptic types, etc. Select the optimal shape in accordance with the workpiece and operating environment. Please contact SMC for shapes not included in this catalog.

Pad Type

| Pad form | Application |
|---|---|
| Flat  | To be used when adsorption surface of work is flat and not deformed. |
| Flat with ribs  | To be used when work is likely to deform or in the case of releasing work certainly. |
| Deep  | To be used when work is curved shape. |
| Bellows  | To be used when there is not enough space to install buffer or adsorption surface of work is slanted. |
| Elliptic  | To be used when work has limited adsorption surface or long in length and work is required to locate precisely. |

| Pad form | Application |
|---|---|
| Ball joint type  | To be used when adsorption surface of work is not horizontal. |
| Long stroke buffer  | To be used when work height is not even or cushioning toward work is required. |
| Large size buffer  | To be used when work is heavy weight. |
| Conductive pad  | As one of the countermeasures against the static electricity, rubber material with reduced resistance is used. For antistatic measures |

● Vacuum Pad Material

- It is necessary to determine vacuum pad materials carefully taking into account the workpiece shape, adaptability in the operating environment, effect after being adsorbed, electrical conductivity, etc.
- Based on the work transfer example for each material, select after confirming the characteristics (adaptability) of rubber.

Vacuum Pad/Example of Work Transfer

Material

| Material | Application |
|---------------------------|--|
| NBR | Transport of general work, Corrugated board, Veneer plate, Iron plate and others |
| Silicon rubber | Semiconductor, Removing from die-casting, Thin work, Food processor |
| Urethane rubber | Corrugated board, Iron plate, Veneer plate |
| Fluororubber | Chemical work |
| Conductive NBR | General work of semiconductor (Static electricity resistance) |
| Conductive silicon rubber | Semiconductor (Static electricity) |

● Buffer Attachment

- Use a buffer when there is a variation in the height of workpieces and fragile workpieces are adsorbed (cushioning is necessary). If it is necessary to further position the pad and the workpiece, use a non-rotating buffer.

Unsteady Distance between Pad and Work

If the pad and the workpiece cannot be positioned properly, such as when picking a workpiece having an uneven height, use a built-in spring type pad with a buffer. This type of pad acts as a cushion between the pad and the workpiece. If it is necessary to further position the pad and the workpiece, use a non-rotating buffer.

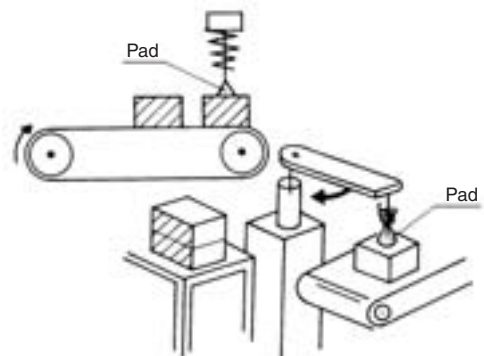

● Pad Selection for Work Types

- Carefully select a pad for the following workpieces.

1. Porous Work

To pick a permeable workpiece such as paper, select a pad with a small diameter that is sufficient to lift the workpiece. Because a large amount of air leakage could reduce the pad's suction force, it may be necessary to increase the capacity of the vacuum pump or enlarge the effective area of the piping passage.

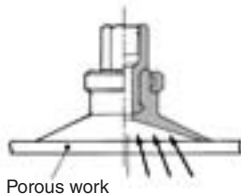

3. Soft Work

If a soft workpiece such as vinyl, paper, or thin sheet is picked up, the vacuum pressure could cause the workpiece to deform or wrinkle. In such a case, it will be necessary to use a small pad or a ribbed pad and reduce the vacuum pressure.

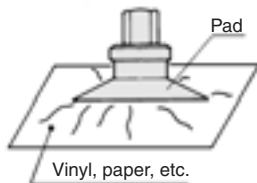

● Vacuum Pad Durability

- Need to be careful of the vacuum pad (rubber) deterioration.
- The vacuum pad's adsorption surface will be worn out when it is used for a certain period of time, and the outer diameter gradually becomes smaller. The lifting force becomes weaker as the pad diameter becomes smaller, but adsorption is still possible.
- Since the vacuum pad replacement period greatly varies depending on the operating environment, it is extremely difficult to estimate the replacement period. Specify the period taking into account the actual operating conditions.

2. Flat Plate Work

When a workpiece with a large surface area such as sheet glass or PCB is suspended, the workpiece could move in a wavelike motion if a large force is applied by wind pressure or by an impact. Therefore, it is necessary to ensure the proper allocation and size of pads.

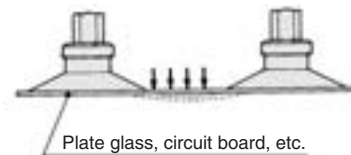

4. Impact to Pad

When pushing a pad to a workpiece, make sure not to apply an impact or a large force which would lead to premature deformation, cracking, or wearing of the pad. The pad should be pushed against the workpiece to the extent that its skirt portion deforms or that its ribbed portion comes into slight contact with the workpiece. Especially, when using a smaller diameter pad, make sure to locate it correctly.

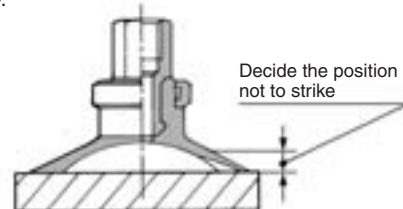

ZA

ZX

ZR

ZM

ZMA

ZQ

ZH

ZU

ZL

ZY□

ZF□

ZP□

SP

ZCUK

AMJ

AMV

AEP

HEP

Related Equipment

Model Selection

3. Selection of Vacuum Ejector and Vacuum Switching Valve

● Calculating Vacuum Ejector and Switching Valve Size with the Formula

Average adsorption flow to achieve adsorption response time

$$Q = \frac{V \times 60}{T_1} + Q_L$$

$$T_2 = 3 \times T_1$$

Q : Average suction flow rate ℓ/min (ANR)

V : Piping capacity (ℓ)

T₁ : Arrival time to stable Pv 63% after adsorption (sec.)

T₂ : Arrival time to stable Pv 95% after adsorption (sec.)

Q_L : Leakage at work adsorption ℓ/min (ANR) ^{Note 1)}

Max. suction flow rate

$$Q_{max} = (2 \text{ to } 3) \times Q \text{ ℓ/min (ANR)}$$

<Selection Procedure>

• Ejector

Select the ejector with the greater maximum suction flow rate from the Q_{max} indicated above.

• Direct operation valve

$$\text{Effective area } S = \frac{Q_{max}}{11.1} \text{ (mm}^2\text{)}$$

* Select a valve (solenoid valve) having an effective area that is greater than that of the effective area formula given above from the related equipment (P. 1278).

Note 1) Q_L: 0 when no leakage occurs when adsorbing a workpiece

If there is leakage when adsorbing a workpiece, find the leakage based on "4. Leakage at Work Adsorption."

Note 2) Tubing piping capacity can be found in "8. Data: Tubing I.D. Piping Capacity (Selection Graph (4))."

4. Leakage at Work Adsorption

Air could be drawn in depending on the type of workpiece. As a result, the vacuum pressure in the pad becomes reduced and the amount of vacuum that is necessary for adsorption cannot be attained.

When this type of workpiece must be handled, it is necessary to select the proper size of the ejector and the vacuum switching valve by taking into consideration the amount of air that could leak through the workpiece.

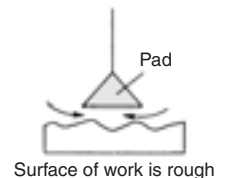
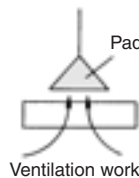

● Leakage from Effective Area of Work

$$\text{Leakage } Q_L = 11.1 \times S_L$$

Q_L: Leakage ℓ/min (ANR)

S_L: Effective area between work and pad, and work opening area (mm²)

● Leakage from Adsorption Test

As described in the illustration below, pick up the workpiece with the ejector, using an ejector, pad and a vacuum gauge.

At this time, read vacuum pressure P₁, obtain the suction flow rate from the flow characteristics graph for the ejector that is being used, and render this amount as the leakage of the workpiece.

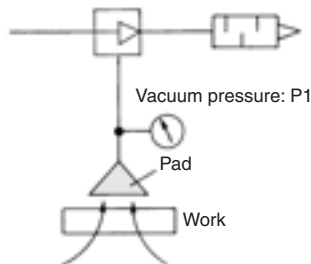

Exercise: Using a supply pressure of 0.45 MPa, when the ejector (ZH07□S) picks up a workpiece that leaks air, the vacuum gauge indicated a pressure of -53 kPa. Calculate the leakage volume from the workpiece.

<Selection Procedure>

When the suction flow rate of -53 kPa is obtained from the ZH07DS flow characteristics graph, the leakage volume is 5 ℓ/min (ANR). (A)→(B)→(C)

Leakage: ≡ Adsorption flow (5 ℓ/min) (ANR)

ZH07BS, ZH07DS

Exhaust Characteristics

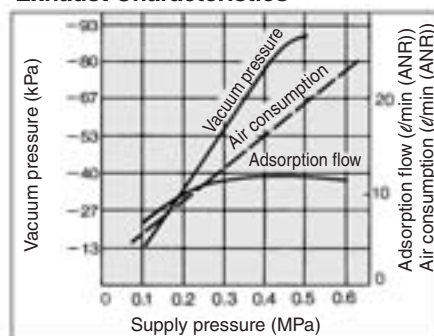

Flow Characteristics

Supply pressure (0.45 MPa)

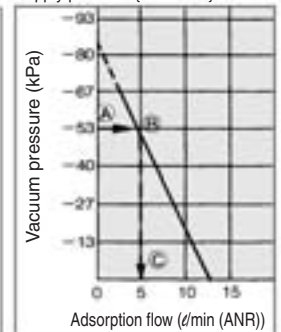

5. Adsorption Response Time

When a vacuum pad is used for the adsorption transport of a workpiece, the approximate adsorption response time can be obtained (the length of time it takes for the pad's internal vacuum pressure to reach the pressure that is required for adsorption after the supply valve {vacuum switching valve} has been operated). An approximate adsorption response time can be obtained through formulas and selection graphs.

● Relation between Vacuum Pressure and Response Time after Supply Valve (Switching Valve) is Operated

The relation between vacuum pressure and response time after the supply valve (switching valve) is operated as shown below.

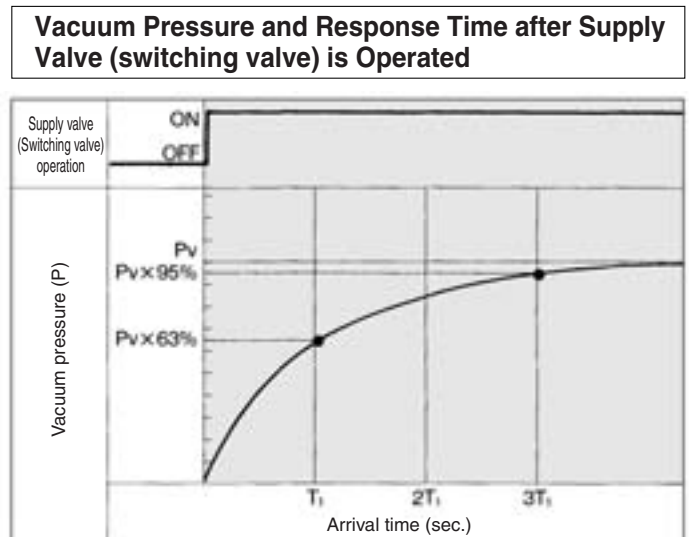
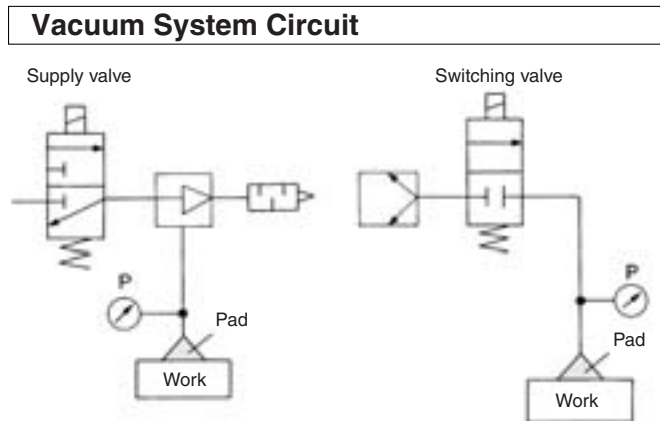

P_v : Final vacuum pressure
 T_1 : Arrival time to 63% of final vacuum pressure P_v
 T_2 : Arrival time to 95% of final vacuum pressure P_v

● Calculating Adsorption Response Time with the Formula

Adsorption response times T_1 and T_2 can be obtained through the formulas given below.

$$\text{Adsorption response time } T_1 = \frac{V \times 60}{Q}$$

$$\text{Adsorption response time } T_2 = 3 \times T_1$$

Piping capacity

$$V = \frac{3.14}{4} D^2 \times L \times \frac{1}{1000} (\ell)$$

T_1 : Arrival time to 63% of final vacuum pressure P_v (sec.)

T_2 : Arrival time to 95% of final vacuum pressure P_v (sec.)

Q_1 : Average adsorption flow ℓ/min (ANR)

Calculation of average adsorption flow

• Ejector

$$Q_1 = (1/2 \text{ to } 1/3) \times \text{Ejector}$$

Max. adsorption flow ℓ/min (ANR)

• Vacuum pump

$$Q_1 = (1/2 \text{ to } 1/3) \times 11.1 \times \text{Effective area of vacuum pump (mm}^2)$$

D : Piping diameter (mm)

L : Length from ejector and switch valve to pad (m)

V : Piping capacity from ejector and switching valve to pad (ℓ)

Q_2 : Max. flow from ejector and switching valve to pad by piping system

$$Q_2 = S \times 11.1 \ell/\text{min (ANR)}$$

Q : Smaller one between the Q_1 and Q_2 ℓ/min (ANR)

S : Effective area of piping (mm²)

For the effective piping area, the equivalent effective area can be found in "8. Data: Effective Area of Tubing I.D. (Selection Graph (5))."

ZA

ZX

ZR

ZM

ZMA

ZQ

ZH

ZU

ZL

ZY□

ZF□

ZP□

SP

ZCUK

AMJ

AMV

AEP

HEP

Related Equipment

Model Selection

● Adsorption Response Time from the Selection Graph

1. Tubing Piping Capacity

Piping capacity from the ejector and switching valve at vacuum pump to the pad can be found in "8. Data: Tubing I.D. Piping Capacity (Selection Graph (4))."

2. Obtaining the adsorption response times

By operating the supply valve (switching valve) that controls the ejector (vacuum pump), the adsorption response times T_1 and T_2 that elapsed before the prescribed vacuum pressure is reached can be obtained from the selection graph (3).

Selection Graph (3) (Adsorption Response Time)

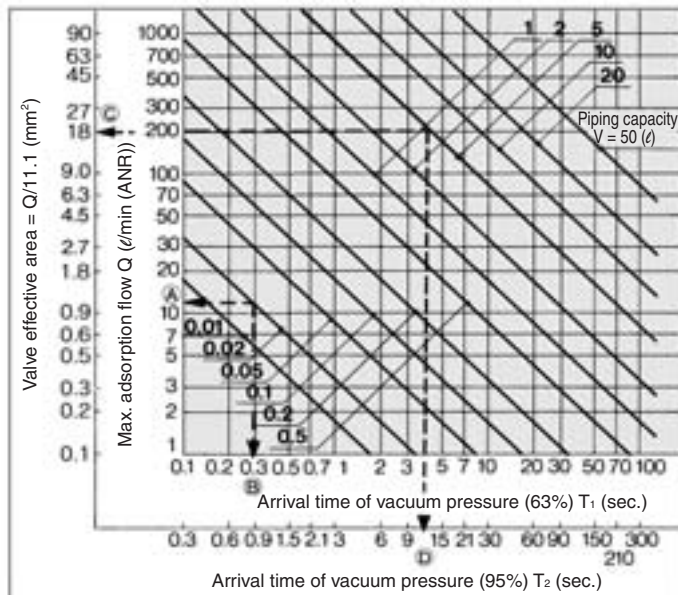

* Conversely, the size of the ejector or the size of the switching valve of the vacuum pump system can be obtained from the adsorption response time.

How to read the graph

Example 1: For obtaining the adsorption response time until the pressure in the piping system with a piping volume of 0.02 ℓ is discharged to 63% (T_1) of the final vacuum pressure through the use of the vacuum ejector ZH07□S with a maximum suction flow rate of 12 ℓ/min (ANR).

<Selection Procedure>

From the point at which the vacuum ejector's maximum vacuum suction flow rate of 12 ℓ/min (ANR) and the piping volume of 0.02 ℓ intersect, the adsorption response time T_1 that elapses until 63% of the maximum vacuum pressure is reached can be obtained. (Sequence in selection graph (3), (A)→(B)) $T_1 \cong 0.3$ seconds.

Example 2: For obtaining the discharge response time until the internal pressure in the 5 ℓ tank is discharged to 95% (T_2) of the final vacuum pressure through the use of a valve with an effective area of 18 mm^2 .

<Selection Procedure>

From the point at which the valve's effective area of 18 mm^2 and the piping volume of 5 ℓ intersect, the discharge response time (T_2) that elapses until 95% of the final vacuum pressure is reached can be obtained. (Sequence in selection graph (3), (C)→(D)) $T_2 \cong 12$ seconds.

6. Precautions on Vacuum Equipment Selection and SMC's Proposal

● Safety Measures

- Make sure to provide a safe design for a vacuum pressure drop due to a disruption of power supply, or a lack of supply air. Drop prevention measures must be taken in particular when dropping a workpiece presents some degree of danger.

● Precautions on Vacuum Equipment Selection

As a countermeasure for power outages, select a supply valve that is normally open or one that is equipped with a self-holding function.

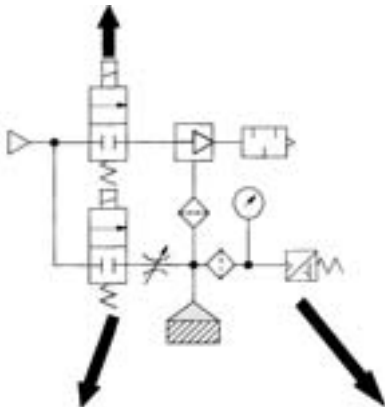

Select a vacuum switching valve that has an effective area that does not reduce the composite effective area consisting of the areas from the pad to the ejector.

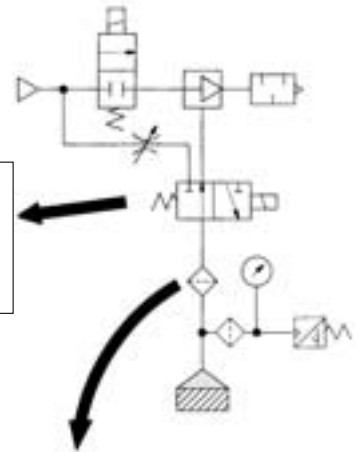

For the release valve, select a 2/3 port valve with a low vacuum specification. Also, use a needle valve to regulate the release flow rate.

- During the adsorption transport of a workpiece, verification of the vacuum switch is recommended.
- In addition, visually verify the vacuum gauge when handling a heavy or a hazardous item.
- The ZSP1 type is the optimal type for the adsorption/transport of small parts using a suction nozzle with a small diameter.
- Install a filter (Series ZFA, ZFB, ZFC) before the pressure switch if the ambient air is of low quality.

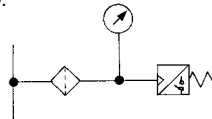

● Vacuum Ejector or Pump and Number of Vacuum Pads

| Ejector and number of pads | | Vacuum pump and number of pads | |
|---|---|---|---|
| | | | |
| Ideally, one pad should be used for each ejector. | When more than one pad is attached to a single ejector, if one of the workpieces becomes detached, the vacuum pressure will drop, causing other workpieces to become detached. Therefore, the countermeasures listed below must be taken. <ul style="list-style-type: none"> • Adjust the needle valve to minimize the pressure fluctuation between adsorption and non-adsorption operations. • Provide a vacuum switching valve to each individual pad to minimize the influences on other pads if an adsorption error occurs. | Ideally, one pad should be used for each ejector. | When more than one pad is attached to a single vacuum line, take the countermeasures listed below. <ul style="list-style-type: none"> • Adjust the needle valve to minimize the pressure fluctuation between adsorption and non-adsorption operation. • Include a tank and a vacuum pressure reduction valve (vacuum pressure regulator valve) to stabilize the source pressure. • Provide a vacuum switching valve to each individual pad to minimize the influences on other pads if an adsorption error occurs. |

- ZA
- ZX
- ZR
- ZM
- ZMA
- ZQ
- ZH
- ZU
- ZL
- ZY□
- ZF□
- ZP□
- SP
- ZCUK
- AMJ
- AMV
- AEP
- HEP
- Related Equipment

Model Selection

● Vacuum Ejector Selection and Handling Precautions

Ejector Selection

There are 2 types of ejector flow rate characteristics: the high vacuum (S type) and the high flow rate (L type). During the selection, pay particular attention to the vacuum pressure when adsorbing workpieces that leak.

High Vacuum Type Flow Characteristics/ZH13□S

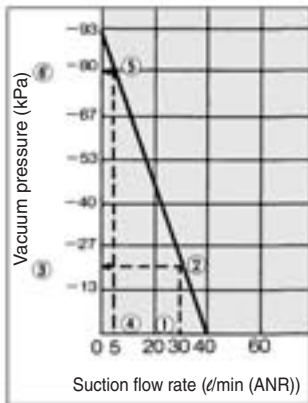

High Flow Type Flow Characteristics/ZH13□L

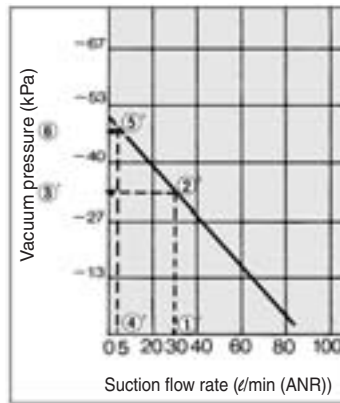

The vacuum pressure varies in accordance with the leakage volumes indicated in the above diagrams.

If the leakage volume is 30 l/min (ANR), the vacuum pressure of the S type is -20 kPa ① → ② → ③, and for the L type it is -33 kPa ①' → ②' → ③'. If the leakage volume is 5 l/min (ANR), the vacuum pressure of the S type is -80 kPa ④ → ⑤ → ⑥, and for the L type it is -47 kPa ④' → ⑤' → ⑥'. Thus, if the leakage volume is 30 l/min (ANR) the L type can attain a higher vacuum pressure, and if the leakage volume is 5 l/min (ANR), the S type can attain a higher vacuum pressure.

Thus, during the selection process, make sure to take the flow characteristics of the high vacuum type (S type) and the high flow rate type (L type) into consideration in order to select the type that is optimal for your application.

- If the vacuum ejector makes an intermittent noise (abnormal noise) from exhaust at a certain supply pressure, the vacuum pressure will not be stable. It will not be any problem if the vacuum ejector is used under this condition. However, if the noise is disturbing or might affect the operation of the vacuum pressure switch, lower or raise supply pressure a little at a time, and use in an air pressure range that doesn't produce the intermittent noise.

● Supply Pressure of Vacuum Ejector

- Use the vacuum ejector at the standard supply pressure.

The maximum vacuum pressure and suction flow rate can be obtained when the vacuum ejector is used at the standard supply pressure, and as a result, adsorption response time also improves. From the viewpoint of energy saving, it is the most effective to use the ejector at the standard supply pressure. Since using it at the excessive supply pressure causes a decline in the ejector performance, do not use it at a supply pressure exceeding the standard supply.

Ejector Nozzle Diameter Selection

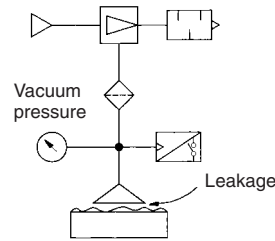

If a considerable amount of leakage occurs between the workpiece and the pad, resulting in incomplete adsorption, or to shorten the adsorption transport time, select an ejector nozzle with a larger diameter from the Series ZH, ZM, ZR, or ZL.

Manifold Use

Individual exhaust

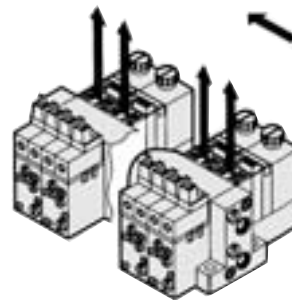

If there are a large number of ejectors that are linked on a manifold and operate simultaneously, use the built-in silencer type or the port exhaust type.

Centralized exhaust

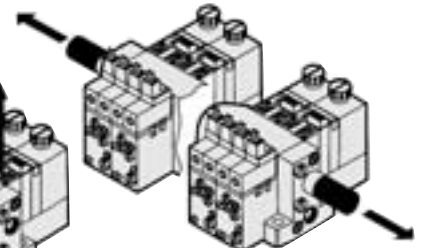

If there are a large number of ejectors that are linked on a manifold, which exhaust collectively, install a silencer at both ends. If the exhaust must be discharged outdoors through piping, make sure that the diameter of the piping is large enough that its back pressure will not affect the operation of the ejectors.

● Timing for Vacuum Generation and Adsorption Confirmation

A. Timing for Generating Vacuum

The time for opening/closing the valve will be counted if a vacuum is generated after the adsorption pad descends to absorb a workpiece. Also, there is a timing delay risk for the generating vacuum since the operational pattern for the verification switch, which is used for detecting the descending vacuum pad, is not even.

To solve this issue, we recommend that vacuum be generated in advance, before the vacuum pad begins to descend to the workpiece.

Adopt this method after confirming that there will be no misalignment resulting from the workpiece's light mass.

B. Adsorption Confirmation

In the case of lifting the vacuum pad after absorbing a workpiece, confirm that there is a suction verification signal from the vacuum pressure switch, before the vacuum pad is lifted. If the vacuum pad is lifted, based on the timing of a timer, etc., there is a risk that the workpiece may be left behind.

In general adsorption transfer, the time for adsorbing a workpiece is slightly different since the position of the vacuum pad and the workpiece are different after every operation. Therefore, program a sequence in which the suction completion is verified by a vacuum pressure switch, etc. before moving to the next operation.

C. Set Pressure for the Vacuum Pressure Switch

Set the optimum value after calculating the required vacuum pressure for lifting a workpiece.

If a higher pressure than required is set, there is a possibility of being unable to confirm the suction even though the workpiece is adsorbed. This will result in a suction error.

When setting vacuum pressure switch set values, you should set using a lower pressure, with which a workpiece can be adsorbed, only after considering the acceleration or vibration when a workpiece is transferred. The set value of the vacuum pressure switch shortens the time to lift a workpiece. Since the switch detects whether the workpiece is lifted or not, the pressure must be set high enough to detect it.

Vacuum Switch (Series ZS), Vacuum Gauge (Series GZ)

When adsorbing and transporting a workpiece, verify at the vacuum pressure switch as much as possible (In addition, visually verify the vacuum gauge, especially when handling a heavy or a hazardous item.).

Approx. $\phi 1$ suction nozzle

The difference in pressure between ON and OFF becomes small depending on the capacity of the ejector and vacuum pump. **In such a case, it will be necessary to use ZSP1 that can detect a small hysteresis or a flow switch.**

- Note) • **A vacuum generator with a large suction capacity will not be detected properly**, so an ejector with an appropriate capacity must be selected.
- Since the hysteresis is small, vacuum pressure must be stabilized.

Typical Operational Pattern Timing Example

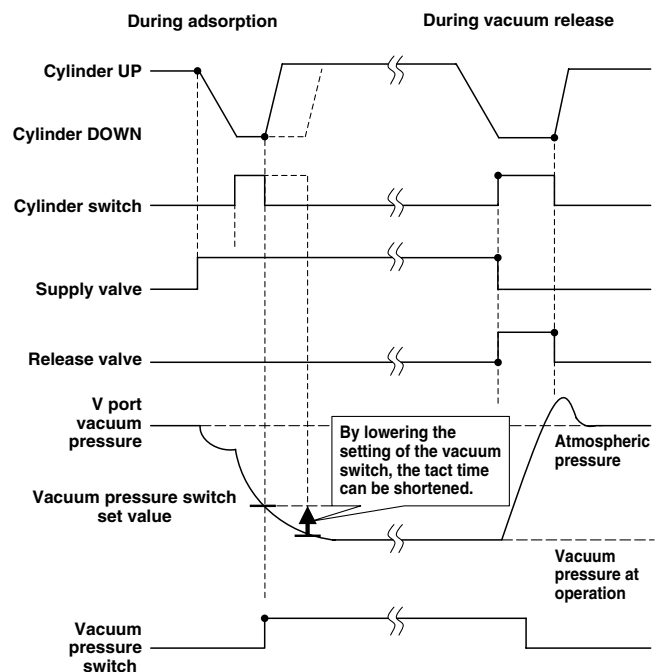

| |
|------|
| ZA |
| ZX |
| ZR |
| ZM |
| ZMA |
| ZQ |
| ZH |
| ZU |
| ZL |
| ZY□ |
| ZF□ |
| ZP□ |
| SP |
| ZCUK |
| AMJ |
| AMV |
| AEP |
| HEP |

Related Equipment

Model Selection

● Dust Handling of Vacuum Equipment

- When the vacuum equipment is used, not only the workpiece, but also dust in the surrounding environment is taken in the equipment. Preventing the intrusion of dust is required more than for any other pneumatic equipment. Some of SMC's vacuum equipment comes with a filter, but when there is a large amount of dust, an additional filter must be installed.
- When vaporized materials such as oil or adhesive are sucked into the equipment, they accumulate inside, which may cause problems.
- It is important to prevent dust from entering the vacuum equipment as much as possible.
 - (1) Make sure to keep the working environment and surrounding area of the workpiece clean so that dust will not be sucked in the equipment.
 - (2) Check the amount and types of dust before using the equipment and install a filter, etc., in the piping when necessary. In particular, equipment used to capture dust, such as a vacuum cleaner, require a special filter.
 - (3) Conduct a test and make sure that operating conditions are cleared before using the equipment.
 - (4) Perform filter maintenance depending on the amount of dirt.
 - (5) Filter clogging generates a pressure difference between the adsorption and ejector parts. This requires attention, since clogging can prevent proper adsorption from being achieved.

Air Suction Filter (Series ZFA, ZFB, ZFC)

- To protect the switching valve and the ejector from becoming clogged, a suction filter in the vacuum circuit is recommended.
- When using an ejector in a dusty environment, the unit's filter will become clogged quickly, so it is recommended that the Series ZFA, ZFB or ZFC be used concurrently.

Vacuum Line Equipment Selection

Determine the volume of the suction filter and the effective area of the switching valve in accordance with the maximum suction flow rate of the ejector and the vacuum pump. Make sure that the effective area is greater than the value that has been obtained through the formula given below. (If the devices are connected in series in the vacuum line, their effective areas must be combined.)

$$S = Q_{\max}/11.1 \quad S: \text{Effective area (mm}^2\text{)}$$

Q_{\max} : Max. adsorption ℓ/min (ANR)

7. Vacuum Equipment Selection Example

● Transfer of Semiconductor Chips

Selection conditions:

- (1) Workpiece: Semiconductor chips
Dimensions: 8 mm x 8 mm x 1 mm, Mass: 1 g
- (2) Vacuum piping length: 1 m
- (3) Adsorption response time: 300 m/sec or less

1. Vacuum Pad Selection

- (1) Based on the workpiece size, the pad diameter is 4 mm (1 pc.).
- (2) Using the formula on page 828, confirm the lifting force.

$$\begin{aligned} W &= P \times S \times 0.1 \times 1/t \\ 0.0098 &= P \times 0.13 \times 0.1 \times 1/4 \\ P &= 3.0 \text{ kPa} \end{aligned} \quad \left\{ \begin{aligned} W &= 1\text{g} = 0.0098\text{N} \\ S &= \pi/4 \times (0.4)^2 = 0.13 \text{ cm}^2 \\ t &= 4 \text{ (Horizontal lifting)} \end{aligned} \right.$$

According to the calculation, -3.0 kPa or more of vacuum pressure can adsorb the workpiece.

- (3) Based on the work shape and type, select:
Pad shape: Flat
Pad material: Silicon
- (4) According to the results above, select a vacuum pad part number ZPT04US-□□.
(Specify the vacuum entry port (□□) from the pad mounting status.)

2. Vacuum Ejector Selection

- (1) Find the vacuum piping capacity.
Assuming that the bore size is 2 mm, the piping capacity is as follows:
 $V = \pi/4 \times D^2 \times L \times 1/1000 = \pi/4 \times 2^2 \times 1 \times 1/1000 = 0.0031\ell$
- (2) Assuming that leakage (Q_L) at adsorption is 0, find the average suction flow rate to meet the adsorption response time using the formula on page 832.

$$Q = (V \times 60) / T_1 + Q_L = (0.0031 \times 60) / 0.3 + 0 = 0.62\ell$$

From the formula on page 832, the maximum suction flow rate Q_{max} is

$$\begin{aligned} Q_{max} &= (2 \text{ to } 3) \times Q = (2 \text{ to } 3) \times 0.62 \\ &= 1.24 \text{ to } 1.86 \ell/\text{min (ANR)} \end{aligned}$$

According to the maximum suction flow rate of the vacuum ejector, a nozzle with a 0.5 diameter can be used.
If the vacuum ejector Series ZX is used, representative model ZX105□ can be selected.
(Based on the operating conditions, specify the complete part number for the vacuum ejector used.)

3. Adsorption Response Time Confirmation

Confirm the adsorption response time based on the characteristics of the vacuum ejector selected.

- (1) The maximum suction flow rate of the vacuum ejector ZX105□ is 5 ℓ/min. From the formula on page 833, the average suction flow rate Q_1 is as follows:

$$\begin{aligned} Q_1 &= (1/2 \text{ to } 1/3) \times \text{Ejector's max. suction flow rate} \\ &= (1/2 \text{ to } 1/3) \times 5 = 2.5 \text{ to } 1.7 \ell/\text{min} \end{aligned}$$

- (2) Next, find the maximum flow rate Q_2 of the piping. The effective piping area S is 1.1 from the selection graph (5). From the formula on page 833, the maximum flow rate is as follows:

$$Q_2 = S \times 11.1 = 1.1 \times 11.1 = 12.2 \ell/\text{min}$$

- (3) Since Q_2 is smaller than Q_1 , $Q = Q_1$.

Thus, from the formula on page 833, the adsorption response time is as follows:

$$\begin{aligned} T &= (V \times 60) / Q = (0.0031 \times 60) / 1.7 = 0.109 \text{ second} \\ &= 109 \text{ msec} \end{aligned}$$

It is possible to confirm that the calculation result satisfies the required specification of 300 msec.

| |
|------|
| ZA |
| ZX |
| ZR |
| ZM |
| ZMA |
| ZQ |
| ZH |
| ZU |
| ZL |
| ZY□ |
| ZF□ |
| ZP□ |
| SP |
| ZCUK |
| AMJ |
| AMV |
| AEP |
| HEP |

Related Equipment

Model Selection

8. Data

● Selection Graph

Selection Graph (4) Tubing I.D. Piping Capacity

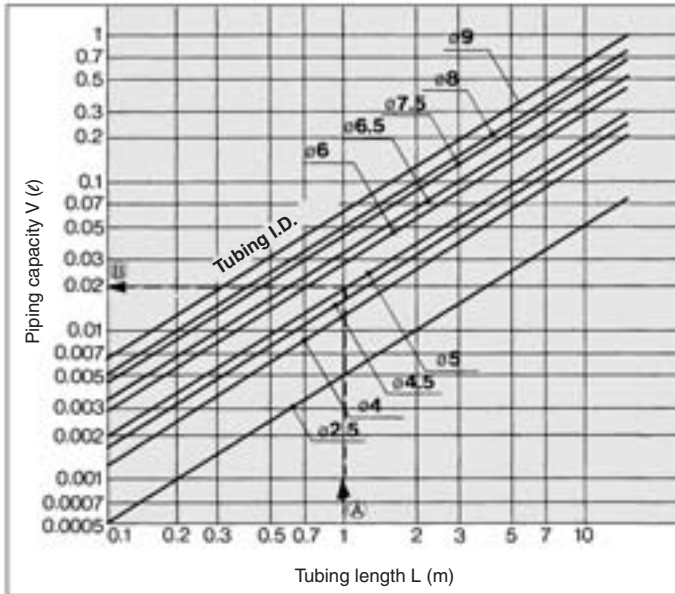

How to read the graph

Example: For obtaining the volume of tubing with bore size of $\phi 5$ mm and 1 meter length.

<Selection Procedure>

By extending leftward from the point at which the 1 meter tubing length intersects the line for a tubing's bore size of $\phi 5$ mm, the piping volume approximately equivalent to 0.02 ℓ can be obtained, on the vertical axis.

Piping capacity: $\cong 0.02 \ell$

Selection Graph (5) Effective area of tubing I.D.

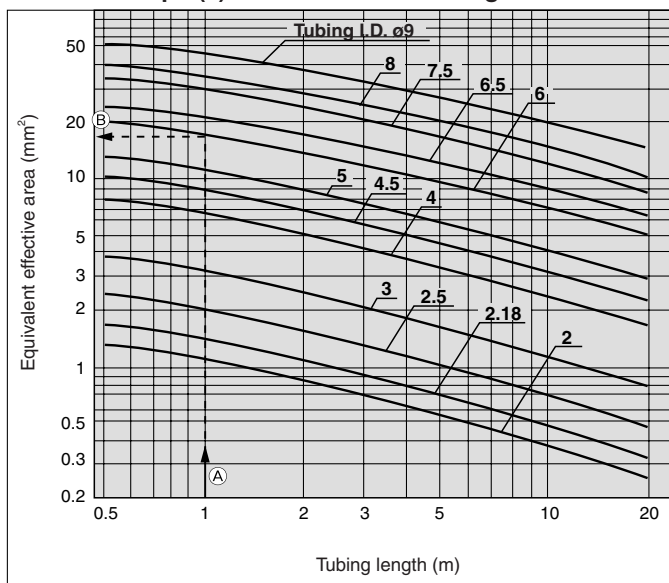

How to read the graph

Example: Tubing size $\phi 8/\phi 6$, 1 m

Selection Procedure

From the point of intersection of tubing length 1 m of lateral axis and tubing I.D. $\phi 6$ mm, the equivalent effective area at vertical axis can be found as approx. 18 mm^2 .

Equivalent effective area: $\cong 18 \text{ mm}^2$

● Glossary of Terms

| Terms | Description |
|--------------------------------|--|
| (Max.) suction flow | Volume of air taken in by the ejector. The maximum volume is the flow rate of the air that is taken in without having anything connected to the vacuum port. |
| Maximum vacuum pressure | The maximum value of the vacuum pressure that is generated by the ejector. |
| Air consumption | The volume of compressed air that is consumed by the ejector. |
| Standard supply pressure | The optimal supply pressure for operating the ejector. |
| Exhaust characteristics | The relationship between the vacuum pressure and the suction flow rate when the supply pressure to the ejector has been changed. |
| Flow characteristics | The relationship between the vacuum pressure and the suction flow rate with the standard supply pressure supplied to the ejector. |
| Vacuum pressure switch | The pressure switch that is used for verifying the adsorption of a workpiece. |
| Adsorption confirmation switch | The switch, based on an air pressure bridge, that is used for verifying the adsorption of a workpiece. It is used when the adsorption pad and the nozzle are extremely small. |
| (Air) supply valve | The valve that supplies compressed air to the ejector. |
| (Vacuum) release valve | The valve that supplied positive pressure or air to break the vacuum state of the adsorption pad. |
| Flow adjustment valve | The valve that supplied positive pressure or air that regulates the flow of the air to break the vacuum. |
| Release pressure | Pressure that is used for breaking the vacuum. |
| Pilot pressure | Pressure that is used for operating the ejector valve. |
| External release | The action of breaking the vacuum using externally supplied air instead of using the ejector unit. |
| Vacuum port | Port for generating vacuum. |
| Exhaust port | Port for exhausting the air, which was used by the ejector, and the air taken in by vacuum port. |
| Supply port | Port for supplying the air, which is used by the ejector. |
| Back pressure | Pressure inside the exhaust port. |
| Leakage | The entry of air into the vacuum passage, such as from an area between a workpiece and a pad, or between a fitting and tubing. The vacuum pressure decreases when leakage occurs. |
| Response speed | The length of time that elapses from when the supply valve or the switching valve is activated until the pressure switch turns ON. It is also called the adsorption time. |
| Average suction flow rate | The suction flow rate of the ejector or the pump, which is used for calculating the response speed. It is $\frac{1}{2}$ to $\frac{1}{3}$ of the maximum suction flow rate. |
| Conductive pad | A pad with a low electrical resistance that is used as an electrostatic prevention measure. |
| Vacuum pressure | Any pressure below the atmospheric pressure. When the atmospheric pressure is used as a reference, the pressure is presented by $-kPa$ (G), and when the absolute pressure is used as a reference, the pressure is represented by kPa (abs). When referencing a piece of vacuum equipment such as an ejector, the pressure is generally represented by $-kPa$. |
| Ejector unit | A device that generates vacuum by means of discharging the compressed air from a nozzle at a high speed, thus utilizing the phenomenon in which the pressure is reduced when the air around the nozzle is sucked. |
| Air suction filter | The vacuum filter that is provided in the vacuum passage in order to prevent the intrusion of dust into the ejector, the vacuum pump, or peripheral equipment. |

ZA
 ZX
 ZR
 ZM
 ZMA
 ZQ
 ZH
 ZU
 ZL
 ZY□
 ZF□
 ZP□
 SP
 ZCUK
 AMJ
 AMV
 AEP
 HEP

Related Equipment

Model Selection

● Countermeasures for the Vacuum Adsorption System Problems (Troubleshooting)

| Condition & Description of improvement | Cause | Remedy |
|--|---|---|
| Initial adsorption problem (During trial operation) | Adsorption area is too small. (Lift force is lower than the workpiece mass.) | Reconfirm the relationship between workpiece mass and lift force. <ul style="list-style-type: none"> • Use a vacuum pad with a large adsorption area. • Increase the quantity of vacuum pads. |
| | Vacuum pressure is too low. (Leakage from adsorption surface) (Air permeable workpiece) | Eliminate (reduce) leakage from adsorption surface. <ul style="list-style-type: none"> • Reconsider shape of vacuum pad. Confirm relationship between suction flow rate and arrival pressure of vacuum ejector. <ul style="list-style-type: none"> • Use a vacuum ejector with a high suction flow rate. • Increase adsorption area. |
| | Vacuum pressure is too low. (Leakage from vacuum pipe) | Repair leakage point. |
| | Internal volume of vacuum circuit is too large. | Confirm the relationship between internal volume of the vacuum circuit and suction flow rate of the vacuum ejector. <ul style="list-style-type: none"> • Reduce internal volume of the vacuum circuit. • Use a vacuum ejector with a high suction flow rate. |
| | Pressure drop of vacuum pipe is large. | Reconsider vacuum pipe. <ul style="list-style-type: none"> • Use a shorter or larger (with appropriate diameter) tube. |
| | Inadequate supply pressure of vacuum ejector | Measure supply pressure in vacuum generation state. <ul style="list-style-type: none"> • Use the standard supply pressure. • Reconsider the compressed air circuit (line). |
| | Clogging of nozzle or diffuser (Infiltration of foreign matter during piping) | Remove foreign matter. |
| | Supply valve (switching valve) has not activated. | Measure supply voltage at the solenoid valve with a tester. <ul style="list-style-type: none"> • Review electric circuits, wiring and connectors. • Use in the rated voltage range. |
| | Workpiece deforms during adsorption. | Workpiece is thin, so it deforms and leakage occurs. <ul style="list-style-type: none"> • Use a pad for adsorption of thin objects. |
| Late vacuum achieving time (Shortening of response time) | Internal volume of vacuum circuit is too large. | Confirm the relationship between internal volume of the vacuum circuit and suction flow rate of the vacuum ejector. <ul style="list-style-type: none"> • Reduce internal volume of the vacuum circuit. • Use a vacuum ejector with a high suction flow rate. |
| | Pressure drop of vacuum pipe is large. | Reconsider vacuum pipe. <ul style="list-style-type: none"> • Use a shorter or larger (with appropriate diameter) tube. |
| | Required vacuum pressure is too high. | Set vacuum pressure to minimum necessary value by optimizing the pad diameter, etc. The lower the vacuum pressure is for ejectors, etc., the larger the suction capacity becomes. If a pad one size bigger is used, the required vacuum pressure is lower and suction capacity increases. |
| | Setting of vacuum pressure switch is too high. | Set to suitable setting pressure. |

Model Selection

| Condition & Description of improvement | Cause | Remedy |
|--|---|--|
| Fluctuation in vacuum pressure | Fluctuation in supply pressure | Reconsider compressed air circuit (line). (Addition of a tank, etc.) |
| | Vacuum pressure may fluctuate under certain conditions due to ejector characteristics. | Lower or raise supply pressure a little at a time, and use in a supply pressure range where vacuum pressure does not fluctuate. |
| Production of abnormal noise (intermittent noise) from exhaust of vacuum ejector | Intermittent noise may occur under certain conditions due to ejector characteristics. | Lower or raise supply pressure a little at a time, and use in a supply pressure range where the intermittent noise does not occur. |
| Air leaks from vacuum port of manifold type vacuum ejector. | Exhaust air from the ejector enters the vacuum port of another ejector that is stopped. | Use a vacuum ejector with a check valve. (Consult with SMC for the part no. of an ejector with a check valve.) |
| Adsorption problem over time (Adsorption was normal during trial operation.) | Suction filter clogging | Replace filters. Improve installation environment. |
| | Clogging of sound absorbing material | Replace sound absorbing material. Add a filter to supply (compressed) air circuit. Install an additional suction filter. |
| | Clogging of nozzle or diffuser | Remove foreign matter. Add a filter to supply (compressed) air circuit. Install an additional suction filter. |
| | Vacuum pad (rubber) deterioration, cracking, etc. | Replace vacuum pad. Confirm compatibility of vacuum pad material and workpiece. |
| Workpiece does not release. | Inadequate release flow rate | Open release flow adjustment needle. |
| | Viscosity increase due to vacuum pad (rubber) wear | Replace vacuum pad. Confirm compatibility of vacuum pad material and workpiece. |
| | Vacuum pressure is too high. Release time is too short. | Set vacuum pressure to minimum necessary value. Provide adequate release time. |
| | Effects due to static electricity | Use a conductive pad. |

ZA

ZX

ZR

ZM

ZMA

ZQ

ZH

ZU

ZL

ZY□

ZF□

ZP□

SP

ZCUK

AMJ

AMV

AEP

HEP

Related Equipment